



Working Together for a
Better Tomorrow. Today.

WATER STORAGE TANK MAINTENANCE PROGRAM

REQUEST FOR PROPOSAL

C130205

Proposals due

Thursday, April 8, 2021 @ 4:00 p.m. (local time)
City of Grand Island, City Hall
100 East 1st Street, P.O. Box 1968
Grand Island, NE 68802-1968

Contact Information

City of Grand Island Utilities Department
Lynn Mayhew, Assistant Utilities Director
Platte Generating Station
Grand Island, NE 68801
O: 308-385-5496

Issued: March 5, 2021

PROPOSAL

**ADVERTISEMENT FOR PROPOSALS
WATER STORAGE TANK MAINTENANCE PROGRAM
FOR
CITY OF GRAND ISLAND, NEBRASKA**

Proposals will be received at the office of the City Clerk, 100 E. First Street, P.O. Box 1968, Grand Island, Nebraska 68802, until Thursday, April 8, 2021 at 4:00 p.m. local time for the above Proposal, FOB the City of Grand Island. Site inspections can be arranged by contacting Lynn Mayhew (308) 385-5494 for an appointment.

Proposals received after the specified time will be returned unopened to sender. Proposals shall include the following on the outside of the envelope **“Proposal for Water Storage Tank Maintenance Program”**. All proposals must be signed and dated in order to be accepted. Proposals shall be addressed to the attention of Lynn Mayhew, Assistant Utilities Director. **Four complete copies with the original** proposal shall be submitted for evaluation purposes if submitting by mail. Proposal package and any Addendas is also available on-line at <http://www.grand-island.com/business/bids-and-request-for-proposals/bid-calendar> under the bid opening date and “Click here for bid document link” through QuestCDN. Submitting through QuestCDN requires one original document of the bid to be uploaded.

Proposals will be evaluated by the Purchaser based on Contractor’s response to the proposal, experience of the company and project personnel, commercial terms, and pricing to perform the project required. All Proposals shall be valid for at least 90 days after the Proposal deadline for evaluation purposes.

The Purchaser reserves the right to reject any or all proposals, to waive irregularities therein, and to accept whichever proposal that may be in the best interest of the City, at its sole discretion.

RaNae Edwards, City Clerk

Advertised

INSTRUCTIONS TO BIDDERS - PROPOSAL

1. GENERAL INFORMATION.

The following instructions outline the procedure for preparing and submitting Bids. Bidders must fulfill all requirements as specified in these Documents.

2. TYPE OF BID.

Bidders shall be required to submit prices for all items listed in the Detailed Specifications.

3. PREPARATION/SUBMISSION OF PROPOSAL.

All Proposals must be submitted intact not later than the time prescribed, at the place, and in the manner set forth in the ADVERTISEMENT FOR BIDS. Proposals must be made on the Company's official letterhead, and must be signed and dated to be accepted. Each Proposal must be submitted intact in a sealed envelope, so marked as to indicate its contents without being opened, and delivered in person or addressed and mailed in conformance with the instructions in the ADVERTISEMENT FOR BIDS.

Proposal package and any Addenda is also available on-line at <http://www.grand-island.com/business/bids-and-request-for-proposals/bid-calendar> under the bid opening date and "Click here for bid document link" through QuestCDN. Submitting through QuestCDN requires one original document of the bid to be uploaded (no zip files). Any Proposal received after the specified date will not be considered. No verbal Proposal will be considered.

The Bidder shall acknowledge receipt of all addenda. Proposals received without acknowledgement or without the Addendum enclosed will be considered informal.

If exceptions and/or clarifications are noted to the proposal, those exceptions must be fully explained on a separate sheet, clearly marked, and included with the Proposal. Any changes that are found made to the original specification, other than Owner generated Addendums, could result in your bid not being considered.

The City reserves the right to reject any or all proposals and to select the proposal, which is deemed to be in the City's best interest, at its sole discretion.

All Proposals shall be valid for at least ninety (90) working days after the Proposal deadline for evaluation purposes.

4. BASIS OF AWARD

The award will be made by the OWNER on the basis of the Proposal from the lowest responsive, responsible Bidder which, in the OWNER's sole and absolute judgment will best serve the interest of the OWNER.

All Proposals will be considered by City water management staff using the point guidelines as follows:

- 1) Overall service provider's qualifications and experience.
- 2) Organizational chart and contact information for personnel.

- 3) Financial stability to successfully complete all associated work.
- 4) Reference from a reputable financial institution.
- 5) Commitment of sufficient staff to provide services.
- 6) Depth of personnel to successfully complete all associated work.
- 7) Respondent has 5+ NACE Certified Inspectors on staff.
- 8) Respondent has 5+ Certified Welders on staff.
- 9) Service center within 350 miles of the City of Grand Island, NE.
- 10) Emergency service response time of 24 hours at no extra cost.
- 11) Respondent has sufficient equipment to complete any associated work.
- 12) All insurance coverages/limits are met (include Certificate of Insurance).
- 13) Respondent submits 5+ customer references.
- 14) Respondent submits 5+ customer references with over ten years of service.
- 15) Overall experience with tank asset management programs.
- 16) History and volume of long-term asset management contracts.
- 17) Ability to dispose of hazardous waste materials from work area.
- 18) Security, health, and safety training (include formal Safety Program).
- 19) Quality Assurance Program in place to meet all regulations/standards.
- 20) Respondent is ISO 9001:2015 Certified (include ISO 9001: 2015 Certificate).
- 21) Approved Applicator Certificate/Reference Letter from paint manufacturers.
- 22) Completeness; all requested information was provided in detail.
- 23) Results of reference check.

The OWNER reserves the right to reject all Proposals, or any Proposal not in conformance with the intent of the Bid Documents, and to waive any informalities and irregularities in said Proposal.

5. EXECUTION OF CONTRACT.

The successful Bidder shall, within fifteen (15) days after receiving notice of award, sign and deliver to the OWNER the Contract hereto attached, if required, together with the acceptable bonds as required in these Bid Documents. Within fifteen (15) days after receiving the signed Contract with acceptable bond(s) from the successful Bidder, the OWNER's authorized agent will sign the Contract. Signature by both parties constitutes execution of the Contract.

Any exceptions and/or clarifications to the specification or Owner's Contract Documents must be addressed prior to receiving notice of award and included with the Proposal.

6. TIME OF COMPLETION.

The time of completion of the Work to be performed under this Contract is the essence of the Contract. Proposals should submit a timeline for completion of the Work unless otherwise stated in the Detailed Specification.

8. GRATUITIES AND KICKBACKS

City Code states that it is unethical for any person to offer, give, or agree to give any City employee or former City employee, or for any City employee or former City employee to solicit, demand, accept, or agree to accept from another person, a gratuity or an offer of employment in connection with any decision, approval, disapproval, recommendation, or preparation of any part of a program requirement or a purchase request, influencing the content of any specification or procurement standard, rendering of advice, investigation, auditing, or in any other advisory capacity in any proceeding or application, request for ruling, determination, claim or controversy, or other particular matter, pertaining to any program requirement or a contract or subcontract, or to any solicitation or proposal therefor. It shall be unethical for any payment, gratuity, or offer of employment to be made by or on behalf of a subcontractor under a contract to the prime contractor or higher tier subcontractor or any person associated therewith, as an inducement for the award of a subcontract or order.

9. FISCAL YEAR

The City of Grand Island, Nebraska operates on a fiscal year beginning October 1st and ending on the following September 30th. It is understood and agreed that any portion of this agreement which will be performed in a future fiscal year is contingent upon the City Council adopting budget statements and appropriations sufficient to fund such performance.

TANK MAINTENANCE SERVICES - CONTRACT AGREEMENT

THIS AGREEMENT made and entered into by and between **[SUCCESSFUL BIDDER]**, hereinafter called the Engineer, and the **CITY OF GRAND ISLAND, NEBRASKA**, hereinafter called the City.

WITNESSETH:

THAT, WHEREAS, in accordance with law, the City has caused contract documents to be prepared and an advertisement calling for proposals to be published for *Water Storage Tank Maintenance Program*; and

WHEREAS, the City, in the manner prescribed by law, has evaluated the proposals submitted, and has determined the aforesaid Engineer to be the responsible proposer, and has duly awarded to the said Engineer a contract therefore, for the sum or sums named in the Engineer's proposal, portions thereof being attached to and made a part of this contract.

NOW, THEREFORE, in consideration of the compensation to be paid to the Engineer and of the mutual agreements herein contained, the parties have agreed and hereby agree, the City for itself and its successors, and the Engineer for itself, him/herself, or themselves, and its, his, or their successors, as follows:

ARTICLE I. That the following documents shall comprise the Contract, and shall together be referred to as the "Agreement" or the "Contract Documents";

1. This Contract Agreement.
2. City of Grand Island's Request for Proposals.
3. [Engineering Company's] Proposal dated [date].

In the event of any conflict between the terms of the Contract Documents, the provisions of the document first listed shall prevail.

ARTICLE II. That the Engineer shall provide the services set forth in this agreement and the attachments thereto in accordance with the normal degree of care and skill of other reputable professionals providing similar services on similar projects of like size and nature for this area;

ARTICLE III. That the City shall pay to the Engineer for the performance of the work embraced in this contract and the Engineer will accept as full compensation therefore the sum (subject to adjustment as provided by the contract) of **[DOLLAR AMOUNT] (\$00.00)** for all services and work covered by and included in the contract award and designated in the foregoing Article II;

payments thereof to be made in cash or its equivalent in the manner provided in the General Specifications.

The total cost of the Contract includes:

Fixed Annual cost per tank:

Burdick Reservoir	\$
Rogers #1	\$
Rogers #2	\$
Kimball	\$
Olson Tower	\$
Total	\$.00

The City of Grand Island, Nebraska operates on a fiscal year beginning October 1st and ending on the following September 30th. It is understood and agreed that any portion of this agreement which will be performed in a future fiscal year is contingent upon the City Council adopting budget statements and appropriations sufficient to fund such performance.

ARTICLE IV. The Engineer hereby agrees to act as agent for the City. The invoice for Engineer's services will be paid after approval at the next regularly scheduled City Council meeting and occurring after departmental approval of invoice. The City Council typically meets the second and fourth Tuesday of each month. Invoices must be received well in advance of Council date to allow evaluation and processing time.

ARTICLE V. The Engineer agrees to comply with all applicable State fair labor standards in the execution of this contract as required by Section 73-102, R.R.S. 1943. The Engineer further agrees to comply with the provisions of Section 48-657, R.R.S. 1943, pertaining to contributions to the Unemployment Compensation Fund of the State of Nebraska. During the performance of this contract, the Engineer and all sub-Engineers agree not to discriminate in hiring or any other employment practice on the basis, of race, color, religion, sex, national origin, age or disability. The Engineer agrees to comply with all applicable Local, State and Federal rules and regulations. The Engineer agrees to maintain a drug-free workplace policy and will provide a copy of the policy to the City upon request. Every public Engineer and his, her or its sub-Engineers who are awarded a contract by the City for the physical performance of services within the State of Nebraska shall register with and use a federal immigration verification system to determine the work eligibility status of new employees physically performing services within the State of Nebraska.

GRATUITIES AND KICKBACKS

City Code states that it is unethical for any person to offer, give, or agree to give any City employee or former City employee, or for any City employee or former City employee to solicit, demand, accept, or agree to accept from another person, a gratuity or an offer of employment in connection with any decision, approval, disapproval, recommendation, or preparation of any part of a program requirement or a purchase request, influencing the content of any specification or procurement standard, rendering of advice, investigation, auditing, or in any other advisory capacity in any proceeding or application, request for ruling, determination, claim or controversy, or other particular matter, pertaining to any program requirement or a contract or subcontract, or to any solicitation or proposal therefor. It shall be unethical for any payment, gratuity, or offer of employment to be made by or on behalf of a subcontractor under a contract to the prime contractor or higher tier subcontractor or any person associated therewith, as an inducement for the award of a subcontract or order.

[SUCCESSFUL PROPOSAL COMPANY]

By _____ Date _____

Title _____

CITY OF GRAND ISLAND, NEBRASKA

By _____ Date _____
Mayor

Attest: _____
City Clerk

The contract is in due form according to law and hereby approved.

_____ Date _____
Attorney for the City



*Working Together for a{PRIVATE }
Better Tomorrow, Today.*

REQUEST FOR PROPOSALS

GENERAL SPECIFICATIONS

The Proposal shall be in accordance with the following and with the attached DETAILED SPECIFICATIONS.

All prices are to be F.O.B. Grand Island, Nebraska. **All prices shall be firm, and shall include all sales and use taxes as lawfully assessed under laws and regulations of the State of Nebraska.**

Proposals shall include the following on the **outside** of the mailing envelope: **"Proposal for Water Storage Tank Maintenance Program"**. All proposals must be signed and dated to be accepted. Proposals shall be addressed to the attention of Lynn Mayhew, Assistant Utilities Director. All proposals submitted by mail must include **four (4) complete copies**. The specification is also available at <http://www.grand-island.com/business/bids-and-request-for-proposals/bid-calendar> under the specified opening date and "Click here for bid document link" through QuestCDN. If submitting through QuestCDN, **one** original document of the proposal and supporting materials is required to be uploaded. All proposals shall be submitted for evaluation purposes to the following on or before Thursday, April 8, 2021 at 4:00 p.m.:

Mailing Address: RaNae Edwards, City Clerk
City Hall
P. O. Box 1968
Grand Island, NE 68802-1968

Street Address: RaNae Edwards, City Clerk
City Hall
100 E. First Street
Grand Island, NE 68801

Any Proposal received after the specified date will not be considered. No verbal Proposal will be considered.

Proposals will be evaluated by the Purchaser based on Contractor's response to the proposal, experience of the company and project personnel, commercial terms, and pricing to perform the project required.

The successful contractor will be required to comply with fair labor standards as required by Nebraska R.R.S.73-102 and comply with Nebraska R.R.S. 48-657 pertaining to contributions to the Unemployment Compensation Fund of the State of Nebraska. Contractor shall maintain a drug free workplace policy. Every public contractor and his, her or its subcontractors who are awarded a contract by the City for the physical performance of services within the State of Nebraska shall register with and use a federal immigration verification system to determine the work eligibility status of new employees physically performing services within the State of Nebraska.

The invoice for Contractor's services will be paid after approval at the next regularly scheduled City Council meeting and occurring after departmental approval of invoice; the City Council typically meets the second and

fourth Tuesday of each month. Invoices must be received well in advance of City Council date to allow evaluation and processing time.

The City reserves the right to reject any or all proposals and to select the proposal, which is deemed to be in the City's best interest, at its sole discretion.

All Proposals shall be valid for at least ninety (90) working days after the Proposal deadline for evaluation purposes.

All Proposals must be signed and dated to be accepted. If exceptions and/or clarifications are noted to the bid, those exceptions must be fully explained on a separate sheet, clearly marked, and included with the Proposal. Any changes that are found made to the original specifications, other than Owner generated Addendums, would result in your bid not being considered. Please contact Lynn Mayhew at 308-385-5494, for questions concerning this specification.

WATER STORAGE TANK MAINTENANCE PROGRAM

REQUEST FOR PROPOSALS DETAILED SPECIFICATIONS

SCOPE

The Grand Island Utilities Department is soliciting proposals for a Full-Service Water Storage Tank Maintenance Program. There are five storage tanks, and City is requesting one Proposal with a plan for each tank, as each one has its own program and proposal. The Full-Service Maintenance and Asset Management Program will include: Engineering, Professional Management, Inspections, Rehabilitation, Repairs, Interior Washouts, Exterior Cleanings, Safety Devices, Visual Inspections, and coating of water storage tanks as well as reporting of activities and results to all state and local agencies as required by law.

WATER SYSTEM DESCRIPTION

The City's water system consists of a well field supplying water to an onsite collection basin with a low pressure pump station. This pumping station transfers water through two (2) 30-inch transmission mains to three (3) reservoir/pumping stations in the City. These high pressure pumping stations and water tower provide water as required for residential and industrial use and fire protection through a single zone pressure distribution grid comprised of approximately 310 miles of cast and ductile iron mains. Five (5) high pressure wells are connected directly to the distribution system, providing additional capacity for emergency only. The systems' operation is monitored at the Burdick and Platte Generating Station's control room by use of a computer based SCADA system. The peak municipal system demand is approximately 26 MGD.

The five tanks to be included in the program are:

1. Kimball Reservoir – 2.75 MG Concrete structure built 1963
2. Burdick Reservoir – 3MG Welded Steel tank constructed 1964
3. Roger Reservoir #1 – 3MG Welded Steel tank constructed in 1970
4. Rogers Reservoir #2 – 3MG Concrete tank constructed 2009
5. Olson Water Tower – 2MG Composite Elevated tank constructed 2018

BACKGROUND

The City's operations and maintenance staff has performed the maintenance and hired contractors for recoating and repairs of the water storage tanks in the past. This required budgeting and Council approval of major work. The management staff is looking to have a more predictable budgeting method to maintain the water storage assets.

REFERENCES

The following Specifications, Codes and Standards may be referenced in this Section. All references are to the latest published edition.

Nebraska Title 179 NAC 22

American Concrete Institute (ACI)

371R-08 Guide for the Analysis, Design and Construction of Elevated Concrete and Composite Steel-Concrete Water Storage Tanks

American Standards for Water Works 2007 Edition

American Institute of Steel Construction (AISC)

S335 Specification for Structural Steel Buildings

American National Standards Institute (ANSI)

B16.5 Pipe Flanges and Flanged Fittings

American Society for Testing Materials (ASTM)

A 123 Zinc Coatings on Iron and Steel Products

A 240 Stainless Steel Plate, Sheet and Strip for Pressure Vessels

A 285 Pressure Vessel Plates, Carbon Steel

A 774 Welded Stainless Steel Fittings

A 778 Welded Stainless Steel Tubular Products

American Water Works Association (AWWA)

C652-02 Disinfection of Water-Storage Facilities

D100-11 Welded Steel Tanks for Water Storage

D102-11 Coating Steel Water Storage Tanks

D107-10 Composite Elevated Tanks for Water Storage

Federal Aviation Administration (FAA)

70/7460-1H Obstruction Marking and Lighting

National Association of Corrosion Engineers (NACE)

RP0178 Recommended Practice - Fabrication Details, Surface Finish Requirements and Proper Design Considerations for Tanks and Vessels to be Lined for Immersion Service

National Sanitation Foundation (NSF)

61 Standard for Drinking Water System Components

Occupational Safety and Health Administration (OSHA)

29 CFR Part 1926 Safety and Health Regulations for Construction

Steel Structures Painting Council (SSPC)

VIS-89 Visual Standard for Abrasive Blast Cleaned Steel

A. ASTM D 16 - Terminology Relating to Paint, Varnish, Lacquer, and Related Products

B. SSPC-SP 3 - Power Tool Cleaning

C. SSPC-SP 6 - Commercial Blast Cleaning

D. SSPC-SP 10/NACE 2 - Near-White Metal Blast Cleaning

E. SSPC-PA2 - Measurement of Dry Film Thickness with Magnetic Gages

PROPOSAL REQUIREMENTS

Company Qualifications

The company managing the tank maintenance program must have at least ten (10) years continuous experience with a tank management program and include the following information for evaluation, or the City may reject the RFP as unresponsive:

- A. Size of company/number of years in business.
- B. Key Contact for Service Scheduling
 - a. Name, Phone, E-mail, Address, Experience
- C. Project Engineer with Nebraska Licensure

- a. Name, Phone, E-mail, Address, Experience
- D. Describe the major types of services or work provided by Company
- E. Describe the ownership of Company, publicly traded, etc.
- F. Describe any Company bankruptcy during the past 5 years.
- G. Describe any major litigation Company is involved in.
- H. For each type of service listed below, indicate the number of projects performed in 2019 and 2020.
 - a. Tank Inspections
 - b. Total Tank Painting Projects
 - c. Tanks under your Management Program
 - i. Designate length of time a utility or company has been in the program
- I. References
 - a. Provide a list of systems that are currently being maintained by the Company in the categories listed below. Include the
 - i. Name of the System
 - ii. Person of Contact
 - iii. Telephone Number
 - iv. email of Contact
 - v. Number of Tank(s) in the System under contract.
- J. Please describe the following references:
 - a. Top 5 largest customers
 - b. 5 Longest existing contracts
 - c. All existing contracts within 500 miles of Grand Island, NE
- K. Each proposal shall include information regarding the Company's abilities to support the City of Grand Island during the execution of this asset maintenance program, including the following:
 - a. Describe Company's tank asset maintenance program and how it supports AWWA requirements.
- L. Describe the following areas of the companies Tank Maintenance program:
 - a. Number of direct employees
 - b. Number of indirect or subcontract employees.
 - c. Describe the Company's workforce, union or non-union.
 - d. Describe any work stoppages in the last three years.
 - e. List the number of Professional Engineers on staff.
 - f. List the number of Structural Engineers on staff.
 - g. List the number of NACE Certified inspectors on staff.
 - h. List the number of SSPC Certified inspectors on staff.
 - i. List any other applicable licensed or certified personnel.
- M. Painting Crews
 - a. Describe the average number of people on a tank renovation crew.
 - b. Describe the average years of experience for a tank renovation crew member
 - c. Describe whether tank renovation crew members are direct employees or subcontract employees.

- d. List the subcontractors that you may utilize for the execution of this contract.
- N. Repair Crews
- a. Describe the average number of people on a service crew
 - b. Describe the average years of experience for service crew member.
 - c. Describe whether service crew members are direct employees or subcontract employees.
- O. Inspectors
- a. Describe average years of experience for an inspector.
 - b. Describe whether inspectors are direct employees or subcontract employees.
- P. The respondent shall possess an ISO 9001:2015 Certification
- a. Companies that do NOT possess an ISO 9001:2015 Certification will not be considered.
 - b. Provide a copy of certification.
- Q. Nebraska State Licenses
- a. Respondent MUST submit proof of current Water Operators for the state of Nebraska.
- R. Company Structure / Ownership Structure
- a. If the proposing company is a sole proprietorship, partnership, or Limited Liability Corporation, a succession plan and guarantee of future performance must be documented in the RFP.
 - b. The primary criteria for approving or denying the contract include the financial and technical capabilities of the private contractor; the reasonableness of the contract terms; the protection of the public/water customer, from risks or subsidization of the contract; the financial terms for the company and impact of the contract on its ability to repay its indebtedness; and inclusion of statutorily required terms. Under the statute, the City may enter a contract with an automatically renewing successive one-year contract and will therefore require reasonable assurances from the firm that future performance under the contract will be secure.
 - c. If one or more owners sell all, or a portion of the company, and/or is deceased prior to the required future tank renovations, the proposal must document the ability of the company to successfully fulfill the requirements outlined in this RFP.
- S. Financial Stability:
- a. Reference from a reputable financial institution.
- T. Service Centers:
- a. Total number of service centers within the United States. (include site locations)
 - b. List the service center your company will be utilizing to complete the work associated with this RFP for the Tank Maintenance Program. The service center must be within 350 miles of the City of Grand Island. The service center must have an emergency response time of 24 hours.
- U. List type of Asset Management System database software utilized to manage the information flow of maintenance programs, resources, records, reports, data, etc.

SERVICES TO BE PROVIDED

- A. Annual tank inspections with a written report.
- B. Interior cleaning and inspection every 3 years with report.
- C. Exterior cleaning, the formation of black streaks down the sides is unacceptable (Past time frame 5 years between cleanings)
- D. Coating maintenance including touch up and complete recoating.
- E. Cathodic Protection on steel tanks.
- F. Repairs to the tanks to maintain functionality
- G. Extent of Service
 - a. The entire tank that holds water, including vents, overflows, inlet structures, mixing systems, FAA lighting, and foundation.
 - b. Does not include level sensing, SCADA, security cameras, inlet and outlet valves. Damage due to natural disasters that would be covered under FM Global insurance.

RENOVATIONS

Proposals shall include the details of appropriate work and renovation plan for the tank. This shall include but not be limited to, the evaluation of the tank with particular regard to the internal and external structural condition of the tank and any of its appurtenances, need for painting, and condition of the foundation.

Additionally, each perspective firm should address the requirements to assume responsibility for all corrections and repairs to the tanks necessitated by acts of vandalism or through normal deterioration.

The proposer shall furnish engineering including a structural evaluation of the tank roof support system, as well as inspection services needed to maintain and repair the tank during the term of the contract. The repairs include: steel or concrete repairs, expansion joints, and manhole covers/gaskets.

DETAILED SCOPE OF WORK AND MAINTENANCE SCHEDULE

Provide a detailed schedule with timeline and methods for pre-meeting, project start, mobilization, initial renovation and repairs, demobilization, inspections with corrective actions if necessary, and any additional work to be performed while under agreement. Provide equipment and coating specifications and NSF certifications where available.

PAINTING SPECIFICATIONS

SURFACE PREPARATION OF STEEL

Prepare steel surfaces in accordance with manufacturer's instructions.

Ensure surfaces are dry.

Exterior: Remove visible oil, grease, dirt, dust, mildew, loose rust, loose paint, and other foreign matter in accordance with SSPC-SP3.

Abrasive Blast-Cleaned Surfaces: Coat abrasive blast-cleaned surfaces with primer before visible rust forms on surface. Do not leave blast-cleaned surfaces uncoated for more than 8 hours.

COATING SYSTEMS FOR *EXTERIOR* Elevated Tower SURFACES

Surface Preparation: Abrasive blast in accordance with SSPC-SP 6.

Prime Coat: Tnemec Series 90-97 Tneme-Zinc or 91-H2O Hydro-Zinc at 2.5 to 3.5 mils DFT.

Intermediate Coat: Tnemec Series 73 Endura-Shield 2.5 to 3.0 mils DFT.

Finish Coat: Tnemec Series 700 HydroFlon at 2.0 to 3.0 mils DFT.

Finish Color: To match existing coatings.

COATING SYSTEMS FOR EXTERIOR Steel Tank SURFACES

Exterior -Epoxy/Urethane

System Type: Polyamide Epoxy/Aliphatic Urethane

Surface Preparation: Power-wash with additives to remove and kill surface contaminants.

Power-tool clean in accordance with SSPC-SP3. Feather edges.

Prime: Tnemec Series 135 Chembuild to all power-tool cleaned areas only. DFT 3.0 to 4.0 mils.

First Coat: Tnemec Series 27 FC Typoxy to all exterior surfaces. DFT 2.5 to 3.5 mils.

Finish Coat: Series 1074U Endura-Shield II to all exterior surfaces. DFT 2.5 to 3.5 mils.

Total DFT: 5.0 to 11.0 mils.

Finish Color: To match original color.

COATING SYSTEMS FOR INTERIOR STEEL TANKS

Interior, Wet:

System Type: Zinc/Epoxy/Epoxy. Tnemec Hydro-System.

AWWA D 102 Paint System: ICS-3.

ANSI/NSF 61 Certified: For use inside potable water storage tanks.

Surface Preparation: SSPC-SP 10/NACE 2.

Primer: Series 91-H₂O Hydro-Zinc DFT 2.5 to 3.5 mils.

Brush primer on seams, angles, and hard to reach area.

Intermediate Coat: Tnemec Series N140 or N140F-1255, Beige, Pota-Pox Plus at 5.0 to 7.0 mils DFT.

Finish Coat: Tnemec series N140 or N140F-15BL, Tank White, Pota-Pox Plus at 5.0 to 7.0 mils DFT.

Total DFT: 11.5 to 14.5 mils.

Finish Color: Tank White.

PROTECTION OF SURFACES

Protect surrounding areas and surfaces not scheduled to be coated from damage during surface preparation and application of coatings.

Immediately remove coatings that fall on surrounding areas and surfaces not scheduled to be coated.

Contractor is responsible for all overspray.

PAINT REPAIR

Damaged Materials: Repair or replace damaged materials and surfaces not scheduled to be coated.

Damaged Coatings: Touch-up or repair damaged coatings. Touch-up of minor damage shall be acceptable where result is not visibly different from adjacent surfaces. Recoat entire surface where touch-up result is visibly different, either in sheen, texture, or color.

Coating Defects: Repair in accordance with manufacturer's instructions coatings that exhibit film characteristics or defects that would adversely affect performance or appearance of coating systems.

CONCRETE EXTERIOR COATING

The concrete exterior has a decorative coating of high build 100 percent acrylic resin polymer such as "Tammscoat" smooth textured protective coating.

TESTING AND DISINFECTION

Contractor shall disinfect the tank in accordance with AWWA C-652 Method 2.

After disinfecting the tank and returning the chlorine residual to normal, two bacteriological tests shall be taken 24 hours apart by the City of Grand Island. Both tests must come back non-detectable.

SAFETY

Provide quality management standards and practices of the firm. Provide a copy of the firm's Safety Program that includes policies fall protection and confined spaces entry procedures, staff training and certification of personnel.

SITE INSPECTION

The Contractor shall visit the City facilities prior to submittal of the Proposal to become familiar with the water system and project scope. Site inspections can be arranged by contacting Lynn Mayhew, 308-385-5494, for an appointment.

PROPOSAL INFORMATION

The Proposal shall provide the annual cost for each tank with any renovations to be spread over five (5) years. Each proposal should include a detailed contract document prepared by Company for the tanks to be included in this RFP. The single Proposal should include a plan for each, as each tank is its own asset and costs need to be designated per asset. The City reserves the right to accept one tank or as many tanks that the budget allows. The specific timeframe for the contract document shall be limited to one (1) year at which time the contract shall be automatically renewed upon payment of the annual base fee. Within the contract document shall be a specific cancellation clause, which indicates procedures that CITY may take for cancellation of the contract, which outlines clearly the costs associated with such cancellation, if any. No short-term multiyear contracts (3-year, 5-year, 10-year) will be considered. The Company will never cancel the contract for any reason other than non-payment by City of Grand Island. The proposal and contract must include a detailed fee schedule with a not-to-exceed inflationary

adjustment factor so the CITY can calculate future maintenance costs. All future work shall be covered by the annual fee adjustment factor, with no extra charges for future work.

PAYMENT

Contract renewal shall be annually starting October 1st of each year with monthly invoicing in twelve (12) equal payments. Invoices should be submitted early enough to allow for 30 days net payment for Council approval.

INSURANCE

The Contractor shall comply with the attached INSURANCE REQUIREMENTS.

GRATUITIES AND KICKBACKS

City Code states that it is unethical for any person to offer, give, or agree to give any City employee or former City employee, or for any City employee or former City employee to solicit, demand, accept, or agree to accept from another person, a gratuity or an offer of employment in connection with any decision, approval, disapproval, recommendation, or preparation of any part of a program requirement or a purchase request, influencing the content of any specification or procurement standard, rendering of advice, investigation, auditing, or in any other advisory capacity in any proceeding or application, request for ruling, determination, claim or controversy, or other particular matter, pertaining to any program requirement or a contract or subcontract, or to any solicitation or proposal therefor. It shall be unethical for any payment, gratuity, or offer of employment to be made by or on behalf of a subcontractor under a contract to the prime contractor or higher tier subcontractor or any person associated therewith, as an inducement for the award of a subcontract or order.

FISCAL YEAR

The City of Grand Island, Nebraska operates on a fiscal year beginning October 1st and ending on the following September 30th. It is understood and agreed that any portion of this agreement which will be performed in a future fiscal year is contingent upon the City Council adopting budget statements and appropriations sufficient to fund such performance.

ATTACHMENTS

Nebraska Title 179 NAC 22

Tank Description and Maintenance History

Kimball Drawings 2003 Roof Repair

PROPOSAL EVALUATION

The proposals will be evaluated by City water management staff using the following guidelines:

FACTORS Rating Scale: 0 = didn't meet, 10 = exceeds

- 1) Overall service provider's qualifications and experience. _____
- 2) Organizational chart and contact information for personnel. _____
- 3) Financial stability to successfully complete all associated work. _____
- 4) Reference from a reputable financial institution. _____
- 5) Commitment of sufficient staff to provide services. _____
- 6) Depth of personnel to successfully complete all associated work. _____
- 7) Respondent has 5+ NACE Certified Inspectors on staff. _____
- 8) Respondent has 5+ Certified Welders on staff. _____
- 9) Service center within 350 miles of the City of Grand Island, NE. _____
- 10) Emergency service response time of 24 hours at no extra cost. _____
- 11) Respondent has sufficient equipment to complete any associated work. _____
- 12) All insurance coverages/limits are met (include Certificate of Insurance). _____
- 13) Respondent submits 5+ customer references. _____
- 14) Respondent submits 5+ customer references with over ten years of service. _____
- 15) Overall experience with tank asset management programs. _____
- 16) History and volume of long-term asset management contracts. _____
- 17) Ability to dispose of hazardous waste materials from work area. _____
- 18) Security, health, and safety training (include formal Safety Program). _____
- 19) Quality Assurance Program in place to meet all regulations/standards. _____
- 20) Respondent is ISO 9001:2015 Certified (include ISO 9001: 2015 Certificate). _____
- 21) Approved Applicator Certificate/Reference Letter from paint manufacturers. _____
- 22) Completeness; all requested information was provided in detail. _____
- 23) Results of reference check. _____

Total Points: _____



Working Together for a Better Tomorrow, Today.

REQUEST FOR PROPOSAL - SITE CONDITIONS

WATER STORAGE TANK MAINTENANCE PROGRAM

Site Visit: Bidders shall visit the site in order to inform themselves of the conditions under which the work is to be performed, concerning the site of the work, the nature of the existing facilities, the obstacles which may be encountered, the sequence of the work, and all other relevant matters concerning the work to be performed. No extra compensation shall be allowed by reason of the failure of such bidder to fully inform themselves of said site conditions prior to the bidding. The Contractor shall employ, so far as possible, such methods and means in the carrying out of their work as will not cause any interruption or interference with the City's operations and any other contractors.

A site visit may be arranged by contacting Lynn Mayhew at (308) 385-5494.

Signature of person visiting site: _____

Signature of Utilities personnel witnessing visit: _____

Date of Visit: _____

MINIMUM INSURANCE REQUIREMENTS
CITY OF GRAND ISLAND, NEBRASKA

The successful bidder shall obtain insurance from companies authorized to do business in Nebraska of such types and in such amounts as may be necessary to protect the Bidder and the interests of the City against hazards or risks of loss as hereinafter specified. This insurance shall cover all aspects of the Bidder's operations and completed operations. Failure to maintain adequate coverage shall not relieve Bidder of any contractual responsibility or obligation. Minimum insurance coverage shall be the amounts stated herein or the amounts required by applicable law, whichever are greater.

1. WORKERS COMPENSATION AND EMPLOYER'S LIABILITY

This insurance shall protect the Bidder against all claims under applicable State workers compensation laws. This insurance shall provide coverage in every state in which work for this project might be conducted. The liability limits shall not be less than the following:

Workers Compensation	Statutory Limits
Employers Liability	\$100,000 each accident
	\$100,000 each employee
	\$500,000 policy limit

2. BUSINESS AUTOMOBILE LIABILITY

This insurance shall be written in comprehensive form and shall protect the Bidder, Bidder's employees, or subcontractors from claims due to the ownership, maintenance, or use of a motor vehicle. The liability limits shall not be less than the following:

Bodily Injury & Property Damage	\$ 500,000 Combined Single Limit
---------------------------------	----------------------------------

3. COMPREHENSIVE GENERAL LIABILITY

The comprehensive general liability coverage shall contain no exclusion relative to explosion, collapse, or underground property. The liability limits shall not be less than the following:

Bodily Injury & Property Damage	\$ 500,000 each occurrence
	\$1,000,000 aggregate

4. UMBRELLA LIABILITY INSURANCE

This insurance shall protect the Bidder against claims in excess of the limits provided under employer's liability, comprehensive automobile liability, and commercial general liability policies. The umbrella policy shall follow the form of the primary insurance, including the application of the primary limits. The liability limits shall not be less than the following:

Bodily Injury & Property Damage	\$1,000,000 each occurrence
	\$1,000,000 general aggregate

5. ADDITIONAL REQUIREMENTS

The City may require insurance covering a Bidder or subcontractor more or less than the standard requirements set forth herein depending upon the character and extent of the work to be performed by such Bidder or subcontractor.

Insurance as herein required shall be maintained in force until the City releases the Bidder of all obligations under the Contract.

The Bidder shall provide and carry any additional insurance as may be required by special provisions of these specifications.

6. CERTIFICATE OF INSURANCE

Satisfactory certificates of insurance shall be filed with the City prior to starting any work on this Contract. **The certificates shall show the City as an additional insured on all coverage except Workers Compensation. The certificate shall state that thirty (30) days written notice shall be given to the City before any policy is cancelled (strike the "endeavor to" wording often shown on certificate forms). If the Bidder cannot have the "endeavor to" language stricken, the Bidder may elect to provide a new certificate of insurance every thirty (30) days during the contract. Bidder shall immediately notify the City if there is any reduction of coverage because of revised limits or claims paid which affect the aggregate of any policy.**

WATER STORAGE TANK MAINTENANCE PROGRAM

Attachments

For your convenience, the following attachments are provided:

Nebraska Title 179NAC 22
Tank Description and Maintenance History
Kimball Drawings 2003 Roof Repair

TITLE 179 PUBLIC WATER SYSTEMS

CHAPTER 22 OPERATION AND MAINTENANCE OF COMMUNITY AND NON-TRANSIENT NON-COMMUNITY PUBLIC WATER SYSTEMS

22-001 SCOPE AND AUTHORITY: These regulations establish minimum requirements for the operation and maintenance of existing community and non-transient non-community (NTNC) public water systems. The authority is found in Neb. Rev. Stat. §§ 71-5301 to 71-5313. These regulations are effective for the purpose of compliance on May 1, 2004.

22-002 COMPLIANCE DATE: These regulations are effective for the purpose of compliance beginning May 1, 2004. Until that date, operation and maintenance requirements for public water systems are found in 179 NAC 2-008.

22-003 DEFINITIONS

Department means the Department of Health and Human Services Regulation and Licensure.

Director means the Director of Regulation and Licensure or his/her authorized representative.

Encroachment means a potential source of contamination located less than a specified minimum horizontal separation distance from a public water supply source or any other likely hazards to the safety of the drinking water quality, pressure, or economies delivered by the system. Examples applicable to community water systems include but are not limited to those potential sources of contamination and minimum horizontal separation distances identified in Attachment 1 of 179 NAC 2-007. Examples applicable to NTNC water systems include but are not limited to those potential sources of contamination and minimum horizontal separation distances identified in 178 NAC 12-003.01B.

22-004 GENERAL OPERATING REQUIREMENTS: All community and NTNC public water systems must:

1. Be operated and supervised by competent personnel possessing a certificate of competency issued by the Director.
2. Assure an adequate supply of safe drinking water on a continuous basis.
3. Notify the Director of any situation with the water system which presents or may present an imminent and substantial hazard to health.
4. Flush and disinfect all newly constructed or serviced storage facilities, wells, and water mains not subject to the requirements of 179 NAC 2-007.02 or 2-007.04.

Disinfection must be accomplished prior to placing the new or repaired portion of the system into service. Disinfection must be accomplished in accordance with the following methods which are incorporated herein by reference. They are available for viewing at the Department of Health and Human Services Regulation and Licensure, Public Health Assurance Division, 301 Centennial Mall South, Lincoln, NE 68509, or they can be obtained from the American Water Works Association, 6666 West Quincey Ave., Denver, CO 80235. Alternate methods may be approved by the Director after consultation.

- a. Water wells
 - (1) Community – C654-97
 - (2) NTNC – C654-97 or requirements of 178 NAC 12-004.05A
 - b. Water Storage – C652-02
 - c. Mains – C651-99
5. Provide or have available personnel, tools, spare parts, work areas, and chemicals necessary to accomplish continuous operation of the system.
 6. Maintain an emergency plan of operations for safeguarding the water supply, protecting the drinking water, and, if necessary, providing for an alternate drinking water supply in the event of natural or man-made disasters. The plan must include a list of individuals who may be called for help in times of disaster, their titles and their phone numbers. This list must be updated annually with a copy provided to the Department. The plan must state the basic domestic water needs and usage under normal conditions. Any special institutional, commercial or industrial users must be shown. Any special back-up or standby equipment or auxiliary power supply must be included as well as alternate sources of supply or bottled water sources. All available chemicals and equipment for the purpose of disinfection must be listed. The emergency plan must outline all emergency operations and must be updated at least every 3 years with copies provided to the Department of Health and Human Services Regulation and Licensure for inclusion in the state Drinking Water Emergency plan located in the Division of Public Health Assurance. The emergency plan must be placed at key locations, clearly marked and readily accessible to utility personnel.
 7. Conduct an on-going program for the effective detection and elimination of cross-connections and the prevention of backflow. Such program is subject to review by the Director and must include and require:
 - a. That there be no unprotected physical connection between the public water system and any pipes, pumps, hydrants, tanks, steam condensate returns, engine jackets, heat exchangers, or other water supplies whereby potentially unsafe water or contaminating materials may be discharged or drawn into the public water system unless first approved by the public water system and then by the Director.
 - b. That the public water system must install or require installation of properly located backflow prevention assemblies, devices or methods appropriate to the potential hazards enumerated in Tables 1 and 2 when such

hazards exist and where, in the opinion of the public water system, effective measures consistent with a potential risk have not been taken. Title 179 NAC 22-003 item 7.b. does not apply to lawn sprinkling systems, with the exception of those with provisions to inject toxic substances including lawn chemicals. A public water system that enacted provisions in its cross-connection control program requiring installation of dual check valves on residential service lines to protect the public water system from low hazard cross-connections prior to [the effective date of these regulations] will be permitted to continue only if such installation was accomplished and maintenance of the devices is performed in accordance with the manufacturer's recommendations.

- c. That there be no interconnection with the public water system and another potable water system unless first approved by the public water system and then by the Director.

TABLE 1

Cross-Connections Rated by Degree of Hazard for Commonly Encountered Equipment and Fixtures and Their Use

[For a more complete list, refer to the Manual of Cross-Connection Control referenced in 179 NAC 22-003 item 7.i.(1)]

Direct or Indirect Potable Water Connections	Hazard	
	High	Low
I. Subject to Back Pressure		
A. Pumps, tanks and lines handling:		
1. Sewage	X	
2. Toxic substances	X	
3. Nontoxic substances		X
B. Water connection to steam and steam boiler		
1. Boiler or steam connection to toxic substances	X	
2. Boiler or steam connection to nontoxic substances (boiler blowoff through air gap)		X
II. Not Subject to Back Pressure		
A. Sewer-connected water line (not subject to waste stoppages)	X	
B. Low inlets to receptacles containing:		
1. Toxic substances	X	
2. Nontoxic substances		X
C. Coils or jackets used as heat exchangers in compressors in lines carrying:		
1. Sewage	X	
2. Toxic substances	X	
3. Nontoxic substances		X
D. Flush valve toilets or urinals	X	
E. Toilet, urinal tanks and approved bathtubs		X
F. Bidets, sitz tanks, or spa, therapy and roman pools not otherwise isolated by design or backflow protectors	X	
G. Valved outlets or fixtures with hose attachments that may constitute a cross-connection to:		
1. Toxic substances	X	
2. Nontoxic substances		X
H. Aspirators that may constitute a cross-connection to:		
1. Toxic substances	X	
2. Nontoxic substances		X

TABLE 2

Permitted Backflow Assemblies, Devices and Methods

Assembly, Device or Method ¹	Degree of Hazard				Installation ^{2,3,4,6}
	Low		High		
	Back Siph-onage	Back Pres-sure	Back Siph-onage	Back Pres-sure	
Air Gap	X	X	X	X	Must be a minimum of 1 inch but not less than 2 times the diameter of the effective spout opening when not affected by side walls, and 3 times the diameter of the effective opening when affected by side walls. Side walls will be assumed to not affect air gaps when they are spaced horizontally a distance greater than 4 times the effective opening from the spout opening.
Atmospheric Vacuum Breaker	X		X		Upright position. No valves downstream. Minimum of 6 inches or listed distance above all downstream piping & flood level rim of receptor ⁵
Double Check Valve Assembly	X	X			Horizontal unless otherwise listed. Requires 1 foot below & sufficient side & head room for testing & maintenance with a maximum of 5 feet above the ground, work floor, or a permanently installed working platform with stairs or ladder affixed. Does not discharge water during normal operation.
Pressure Vacuum Breaker Assembly	X		X		Upright position. May have valves downstream. Minimum of 12 inches above all downstream piping & flood level rim of receptor. May discharge water.
Reduced Pressure Principle Backflow Prevention Assembly	X	X	X	X	Same as Double Check Valve Assembly above except may discharge water & wherever installed, provision for draining away at least 2 times the rated gallons per minute of the assembly must be made.

Footnotes:

¹ For description of assemblies and devices, refer to the Cross-Connection Control Standards found in 179 NAC 22-003 item 7.i. Backflow preventers described herein and in the standards as "assemblies" must be installed as assemblies keeping the shutoff valves intact. Examples of sites having potential cross-connections are found in the manuals referenced in 179 NAC 22-003 item 7.i.

- ² Previous approval by the public water system is required for use of a pit or vault (normally prohibited due to possible flooding) or for parallel and bypass installations (normally prohibited without special design considerations and proper cross-connection controls).
- ³ Backflow preventers must not be located in any area containing fumes that are toxic, poisonous or corrosive; nor in any area in which they could be damaged by freezing, or by excessively high temperatures or pressures, vibration, physical impact or structural stress; nor knowingly be allowed to conduct highly corrosive or sandy waters without a special testing and maintenance program to assure proper & safe operation.
- ⁴ Refer to general and specific installation requirements as stated in the Cross-Connection Control Standards provided for in 179 NAC 22-003 item 7.i.(1) for conditions or situations not otherwise covered in these regulations.
- ⁵ Not to be subjected to operating pressure for more than 12 hours in any 24-hour period. Hose bibb vacuum breakers are permitted for some uses described in the Cross-Connection Control Standards listed in 179 NAC 22-003 item 7.i.(1). Where required under 179 NAC 22-003 item 7.b., hose bibbs must be protected with approved, anti-siphoning hose bibb vacuum breakers or a hose bibb with integral backflow protection. In hose bibb installations subject to freezing, such hose bibb vacuum breakers must be frost-proof and self-draining.
- ⁶ Fire protection systems as a minimum must be equipped with backflow prevention devices as described in AWWA Manual M-14, second edition. Backflow preventers under this regulation and connected to fire protection systems must be considered part of those systems. As such, they must not be installed, moved, removed, replaced, shut off or in any way altered unless in strict compliance with the rules and regulations promulgated by the State Fire Marshal.
 - d. That all backflow protection devices equipped with test ports be tested as often as required by the public water system but at least once each year by a Grade 6 certified water operator, with test results certified to the public water system as often as required by the public water system, but in no case more than 30 calendar days after the test. Title 179 NAC 22-003 item 7.d. does not apply to lawn sprinkling systems, with the exception of those with provision to inject toxic substances including lawn chemicals.
 - e. That the public water system require its consumers to assess and report potential backflow hazards on their premises no less often than every five years and to take any steps necessary for protection of public health and safety as reasonably requested by the public water system.
 - f. That the public water system must maintain, or cause to be maintained, records of locations, types, tests and repairs of backflow preventers for a period of five years of said tests and repairs.
 - g. That backflow preventers required by this regulation must have been tested and approved or listed for the intended use by one of the following organizations:

- (1) Foundation for Cross-Connection Control and Hydrologic Research, University of Southern California, University Park, Los Angeles, California 90089.
 - (2) American National Standards Institute, 1430 Broadway, New York, New York 10018.
 - (3) Underwriters Laboratories Inc., 333 Pfingsten Road, Northbrook, Illinois 60062.
 - (4) National Sanitation Foundation, 2355 West Stadium Boulevard, P.O. Box 1468, Ann Arbor, Michigan 48106.
 - (5) International Association of Plumbing and Mechanical Officials, 5032 Alhambra Avenue, Los Angeles, California 90032.
- h. That an on-going public information program must be conducted by the public water system to further the public water system customers' understanding and awareness of cross-connection hazards, the types of remedies available and the need to protect the public water system against backflow no less often than once per year.
- i. That approval of Cross-Connection Control Programs (including as a minimum, backflow preventers, their installation, operation, testing, maintenance and repair) must be based on the following standards.
- (1) Manual of Cross-Connection Control, published by the Foundation for Cross-Connection Control and Hydraulic Research, University of Southern California, ninth edition, a copy of which is available for viewing at the Office of the Nebraska Department of Health and Human Services Regulation and Licensure, Public Health Assurance Division, 301 Centennial Mall South, Lincoln, NE 68509. Said manual may be obtained from the Foundation for Cross-Connection Control and Hydraulic Research, University of Southern California, KAP-200 University Park MC-2531, Los Angeles, CA 90089-2531.
 - (2) American Water Works Manual, M-14, second edition, a copy of which is available for viewing at the Office of the Nebraska Department of Health and Human Services Regulation and Licensure, Public Health Assurance Division, 301 Centennial Mall South, Lincoln, NE 68509. Said manual may be obtained from the American Water Works Association, 6666 West Quincey Ave., Denver, CO 80235.

22-005 GENERAL MAINTENANCE: All community and NTNC public water systems must adopt and carry out a preventive maintenance program incorporating the following elements:

1. Secure all water system facilities in a manner that protects the supply from contamination and prevents unauthorized entry and vandalism.

2. Inspection, servicing, replacement, and record keeping of all mechanical equipment in accordance with manufacturer's recommendations for such maintenance. An operation and maintenance manual must be maintained and updated when facility equipment changes occur. The operation and maintenance manual must include specification of equipment and recommended maintenance practices of that equipment as specified by the manufacturers.
3. Prevention of rust and corrosion by application of paint, protective coatings, cathodic protection, or other treatment capable of prolonging the useful life of the system.
4. Maintaining a system of records for the owner's annual review of the capability of the source of supply, treatment, storage, and distribution facilities to provide for future service demands both short-term and long-term (2 and 10 year plans);
5. Take all available action as necessary to protect the system and its components from encroachments which are likely hazards to the safety of the drinking water quality, or which could have a substantial impact on the system pressure or economies delivered by the system. Such action includes the adoption of ordinances, regulations, contracts, or other enforceable instruments necessary to ensure adequate protection from such encroachments. This may include issues such as zoning, water rights, condemnation, land purchases, easements, abandonment of old wells, and establishing lakes, lagoons, drainage ways, special use areas, and sanitary and water districts.
6. Have arrangements made for obtaining disinfection equipment to apply emergency disinfection within 24 hours of an incident that potentially impacts the microbiological quality of the drinking water.
7. If the system disinfects, have available equipment for accurate measurement of disinfectant residual.

22-006 WELLS AND PUMPING FACILITIES: All NTNC public water systems must comply with the first four of the following items. All community public water systems must comply with all the following items.

1. Maintain a sanitary seal on each wellhead.
2. Seal cracks and crevices to prevent entry of vermin, flooding, or other contaminants.
3. Maintain down-turned well casing vents, and where applicable, air release/vacuum relief valves, with 24-mesh corrosion resistant screens.
4. Tightly seal all penetrations into the upper terminus of the well casing.
5. Maintain a means to pump each well to waste.
6. Provide a labeled, dedicated electrical outlet, in each appropriate location for chemical feed equipment.
7. Have a chemical tap available on the finished water discharge line located downstream from the check valve.
8. For systems that are required to disinfect on a continuous basis and have treatment facilities that are not staffed 24 hours per day, the system must provide a means by which a disinfectant is applied accurately on a continuous basis. This does not

- apply to systems under an Administrative Order that require chlorination for only six months.
9. Record accurate measurement of gallons of water pumped per minute (gpm) and the time pumped or total gallons pumped, for each well not less than once per week.
 10. Measure and record static water levels and pumping water levels, and calculate available drawdown in each active well at a frequency of no less than once every three months from October 1 through April 30 of each year, and at a frequency of no less than once per month from May 1 through September 30 of each year. Static and pumping levels must be expressed as the distance in feet from the measuring point at the upper terminus of the well to the water level in the well. Available drawdown must be expressed as the distance in feet between the static water level and the top of the well screen or pump intake whichever is located nearer to the static water level.
 11. Have a readily accessible auxiliary power source to provide a supply of safe drinking water for emergency use within 24 hours.
 12. Provide and maintain on the premises signage for emergencies and chemical hazards in accordance with 179 NAC 22 Attachment 1.
 13. Maintain clean well houses and pumping facilities for the purpose of producing safe drinking water with the emphasis on easy access to those system components requiring periodic attention.

22-007 DISTRIBUTION SYSTEMS: All community and NTNC public water systems must:

1. Operate to maintain a minimum positive pressure of 20 psi throughout the distribution system except under extraordinary conditions such as unusual peak fire flow demand or major distribution system breaks.
2. Maintain an up-to-date map of the distribution system showing locations, sizes and materials of underground lines and appurtenances.
3. Following a drop in system pressure to less than 20 psi, but maintaining a positive pressure, collect a minimum of two water samples at least 24 hours apart from each affected zone on the sample site plan. All samples must be collected within five working days of the recorded drop in system pressure and submitted for analysis to the Department Laboratory or to a laboratory that has entered into an agreement with the Department pursuant to 179 NAC 3-009. If any samples collected pursuant to the requirements of 179 NAC 22-006 item 3 show the presence of coliform organisms, disinfection procedures must be accomplished in accordance with AWWA Standard C651-99. Alternate disinfection procedures may be used after consultation with and approval by the Director. If used, alternate disinfection procedures must continue until collection of water samples as prescribed in 179 NAC 22-006 item 3 show the complete absence of coliform organisms.
4. When system pressure is completely lost, collect a minimum of two sets of five samples from each affected zone on the sample site plan. Each set must be collected at least 24 hours apart. All samples must be collected within five working days of the recorded complete loss in system pressure and submitted for analysis to the Department Laboratory or a laboratory that has entered into an agreement with the Department pursuant to 179 NAC 3-009. If any samples collected pursuant to the requirements of 179 NAC 22-006 item 4 show the presence of coliform

organisms, disinfection procedures must be accomplished in accordance with AWWA Standard C651-99. Alternate disinfection procedures may be used after consultation with and approval by the Director. If used, emergency disinfection procedures must continue until collection of water samples as prescribed in 179 NAC 22-006 item 4 show the complete absence of coliform organisms.

22-008 POTABLE WATER STORAGE FACILITIES: All community and NTNC public water systems must:

1. Inspect, and clean if necessary, water storage facilities equipped for accessibility, no less than once every five years.
2. Secure the storage facility by use of locks on access manholes and hatches, and take other necessary precautions to prevent trespassing, vandalism, and sabotage.
3. Provide and maintain corrosion resistant screen of an effective mesh size on water storage structure vents. Screen mesh size must be proper for the vent design. Replace when necessary with in-kind screen.
4. Maintain water tightness, as designed, of walls, floor, and roof to prevent the entrance of nonpotable water, birds, and other contaminant sources.
5. Provide and maintain a corrosion resistant screen of effective mesh size and/or a self-closing flap valve installed near or at the termination of all overflow lines on water storage structures. Screen mesh size and flap valves must be proper for the overflow line design. Replace when necessary with in-kind screen and/or flap valve. The termination point of the overflow lines must be maintained so that overflow discharge does not create, or contribute to, an erosion problem.

22-009 TREATMENT: All community and NTNC public water systems that use a process for removal of a primary or secondary contaminant, or apply chemicals for the purpose of conditioning, continuous disinfection, or adjustment of drinking water must:

1. Maintain and record accurate measurement of chemical use no less often than five days per week.
2. Provide an ammonia solution for use in detecting chlorine leaks when gas chlorination is used,.
3. Store chemicals in accordance with manufacturer's recommendations for chemical compatibility.
4. Maintain color coding in accordance with the following color scheme, or utilize other identification to easily differentiate between pipes.

Water Lines

Raw	Olive Green
Settled or Clarified	Aqua
Finished or Potable	Dark Blue

Chemical Lines

Alum or Primary Coagulant	Orange
Ammonia	White
Carbon Slurry	Black
Caustic	Yellow with green band
Chlorine (gas and solution)	Yellow
Fluoride	Light blue with red band
Lime Slurry	Light green
Ozone	Yellow with orange band
Phosphate Compounds	Light green with red band
Polymers or Coagulant Aids	Orange with green band
Potassium Permanganate	Violet
Soda Ash	Light green with orange band
Sulfuric Acid	Yellow with red band
Sulfur Dioxide	Light green with yellow band

Waste Lines

Backwash Waste	Light brown
Sludge	Dark brown
Sewer (sanitary or other)	Dark gray

Other

Compressed Air	Dark green
Gas	Red
Other Lines	Light gray

5. Where applicable, maintain operational records and filtration log used in conjunction with treatment processes used for removal or inactivation of regulated contaminants for a minimum of five years.
6. If disinfecting, provide approved methodology equipment for accurate measurement of disinfectant residual.
7. When treating to remove or inactivate regulated contaminants, provide proper test equipment to determine process control changes.
8. For systems that are required to disinfect on a continuous basis and have treatment facilities that are not staffed 24 hours per day, the system must provide a means by which a disinfectant is applied accurately on a continuous basis. This does not apply to systems under an Administrative Order that require chlorination for only six months.

9. Record accurate measurement of gallons of water pumped per minute (gpm) and the total time pumped or total gallons pumped of each treatment plant not less than once per week.
10. Provide functional operational controls for each filter used in conjunction with treatment processes consisting of removal of regulated contaminants.

22-010 RECORDS

1. All community and NTNC public water systems must maintain the following records for a minimum of five years:
 - a. Written public health-oriented customer complaints related to water quality, quantity, pressure and system integrity.
 - b. Water main repair and replacement records, including results of special samples collected for microbiological water quality analysis, and disinfection method associated with repair and replacement.
 - c. Chemical use, where applicable.
 - d. Records of process control test results, test equipment quality assurance, and quality control.
2. All community and NTNC public water systems must maintain records pertaining to cleaning, inspection, repair, and protective coatings on water storage facilities for a minimum of 20 years.

179 NAC 22 -- Attachment 1

This attachment prescribes the minimum hazardous material signage that water system facilities must place on entrances to chemical storage facilities as well as on bulk chemical storage containers and chemical day tanks.

I. Entrances to water system facilities and/ or rooms within water system facilities that store or use hazardous chemicals as part of the treatment process:

Precautionary entrance labeling identifying the hazardous chemical: This labeling shall contain the following.

- A. Common name of the chemical
- B. A signal word such as "WARNING" or "DANGER" as described below.
 - 1. Signs depicting "WARNING" must be yellow with black lettering to identify a potentially hazardous situation.
 - 2. Signs depicting "DANGER" must have the word "DANGER" highlighted on a bright red background and be used for conditions that indicate an immediately hazardous situation.
- C. Identification of the key hazard such as flammable or vapor harmful, etc.
- D. A statement of precaution to avoid the hazards.
- E. A color-coded diamond that readily distinguishes the degree of emergency health hazard (blue), fire hazard (red), reactivity hazard (yellow), and any other special hazards the chemical may represent. The following describes the appropriate labeling conditions.

FIRE HAZARD -----RED

0 --- WILL NOT BURN

1 --- WILL IGNITE IF PREHEATED

2 --- WILL IGNITE IF MODERATELY HEATED

3 --- WILL IGNITE AT MOST AMBIENT CONDITIONS

4 --- BURNS READILY AT AMBIENT CONDITIONS

HEALTH HAZARD -----BLUE

- 0 --- MINIMAL HAZARD
- 1 --- SLIGHTLY HAZARDOUS
- 2 --- HAZARDOUS
- 3 – EXTREME DANGER
- 4 – DEADLY

REACTIVITY HAZARD ---- YELLOW

- 0 – STABLE AND DOES NOT REACT WITH WATER
- 1 – UNSTABLE IF HEATED
- 2 – VIOLENT CHEMICAL CHANGE
- 3 – SHOCK AND HEAT MAY DETONATE
- 4 – READILY CAPABLE OF DETONATION AT NORMAL TEMPERATURE AND PRESSURE

SPECIFIC HAZARDS – WHITE

- OX --- OXIDIZER
- ACID --- ACID
- ALK --- ALKALINE
- COR – CORROSIVE
- W – REACTIVE WITH WATER



RADIOACTIVE

- F. All the above information can be obtained from the chemical Material Safety Data Sheets (MSDS) for each chemical. The public water system must retain the most current copy of all MSDS(s) for all chemicals used in the treatment of potable water and have the MSDS located in an area so that they are available and accessible to all water operators and facility personnel.

- G. All signage installed on entrances to water treatment facilities or rooms within the facilities must be located so that signage is readily visible to individuals entering the facility or rooms within the facility.

II. LABELING OF BULK TANK CHEMICAL STORAGE AND OR DAY-TANK CHEMICAL STORAGE

- A. All bulk chemical storage tanks must be labeled as follows:
 - 1. The common name of the chemical
 - 2. The appropriate color-coded diamond with four quadrants designating the degree of emergency health hazard (blue), fire hazard (red), reactivity hazard (yellow), and any other special hazards as designated in the remaining quadrant (white). The coding for each hazard is described in 179 NAC 22 Attachment 1 item I.E.. The size of characters in this signage must be a minimum of 4 inches tall and placed so that the signage is visible from 200 feet away.
- B. All day-tank chemical storage tanks are to be labeled in the same manner as described above with the signage characters a minimum of 3 inches in height and signage placed so it is visible a minimum of 100 feet away.

Tank Descriptions and Maintenance History

Kimball Reservoir

Constructed in 1963 Capacity 2.75 MG

Cast in place Concrete Construction with Brick exterior

Location Corner of North Kimball St and North Front Street

Last inspection 3/2018 – Pictures and videos of interior are available, Leak test little to no water loss.

Last major work was roof repair in 2003



Figure 1 Kimball 2018



Figure 2 Kimball 2018

Burdick Reservoir

Constructed in 1964 Capacity 3 MG

Welded Steel Construction

Location 508 South Stuhr Rd

Last inspection 10/2017 – Pictures of interior are available

Major work History

1990 - The reservoir was painted. (All surfaces blasted, 5 mil epoxy primer, 1.5 mil urethane top coat. All coats brushed on.

May 2001 - W.S. Bunch painted the reservoir. (2500-3000 psi power wash, rusted areas power tool cleaned to bare metal, bare metal primed with Tnemec Series 18 2-4 mils, entire tank painted with one coat Series 30 at 3-4 mils)

May 2002 - W.S. Bunch performed repair work on the areas that had failed (from the previous year). (Power wash all surfaces with 3000-4000 psi TSP solution, scrape loose paint, sand failed surfaces with 60 grit paper, prime areas of failed coating and along the entire base of the tank, apply one coat Series 30 spray safe.

May 2002 began failing a few months later along with continued failure of the previous coating from 2001.

2011 Interior and Exterior Blast and recoat

Interior

Prime Coat: Tnemec Series 91-H2O Hydro-Zinc at 2.5 to 3.5 mils DFT.

Intermediate Coat: Tnemec Series N140 or N140F-1255, Beige, Pota-Pox Plus at 5.0 to 7.0 mils DFT.

Finish Coat: Tnemec series N140 or N140F-15BL, Tank White, Pota-Pox Plus at 5.0 to 7.0 mils DFT.

Exterior

Prime Coat: Tnemec Series 90-97 Tneme-Zinc or 91-H2O Hydro-Zinc at 2.5 to 3.5 mils DFT.

Intermediate Coat: Tnemec Series 73 Endura-Shield 2.5 to 3.0 mils DFT.

Finish Coat: Tnemec Series 700 HydroFlon at 2.0 to 3.0 mils DFT.

April 2019 Interior paint was touched up with Tnemec Epoxoline 141 where the final coat was coming off.



Figure 3 Burdick Interior 2019

Rogers Reservoir #1

Constructed in 1970 Capacity 3 MG

Welded steel construction

Location 3990 Old Potash Hwy

Last inspection 11/2016

Last major work was

Interior Paint touch up 3/2018 – Epoxoline Series FC22

New cathodic protection 2017

Interior blast and paint 10/2016

Exterior blast and paint 3/2010



Figure 4 Roger #1 Interior Touch up 2018



Figure 5 Rogers #1 Exterior 2009

Rogers Reservoir #2

Constructed in 2009 Capacity 3 MG

Concrete Pre-stressed construction by Natgun

Location 3990 Old Potash Hwy

Last inspection 3/2018 – Pictures and videos of interior are available

Last repair was during the 2018 inspection it was found that in the area where the construction opening was filled in was bulging, Natgun repaired the area.



Figure 6 Rogers #2 repaired area



Figure 7 Rogers #2 Exterior 2010



Figure 8 Rogers Pumping Station

Olson Water Tower

Constructed in 2018 Capacity 2 MG

Concrete Pedestal and Welded steel tank construction by Landmark

Location 997 South Engleman Road

Last inspection 10/2019 – 1 Year warranty inspection



Figure 9 Olson Tower internal mix piping

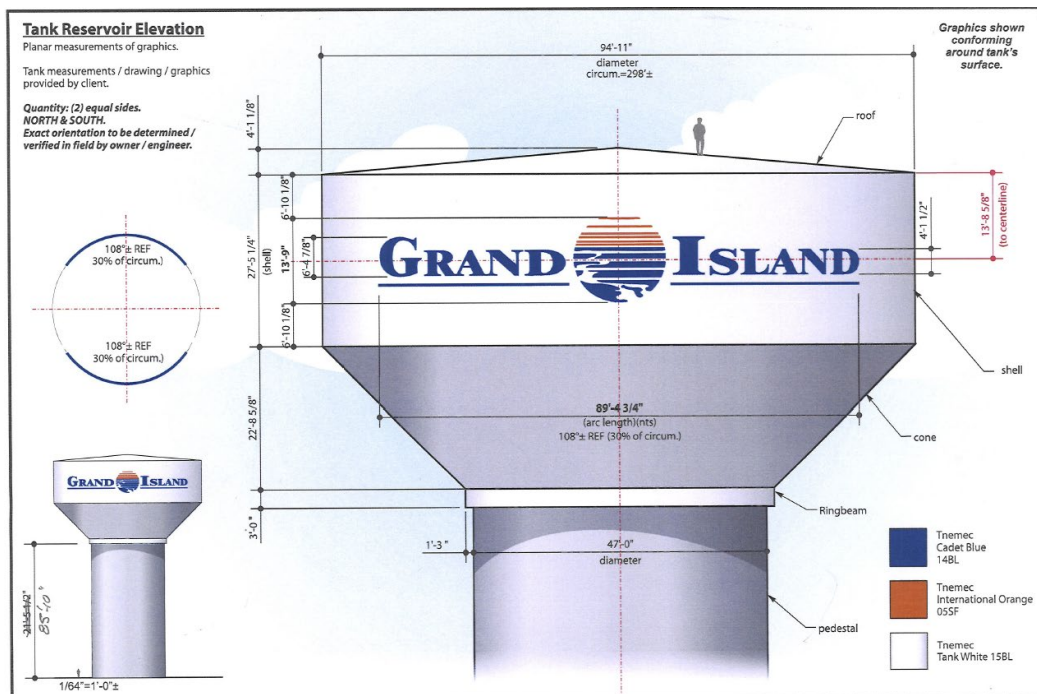

Figure 10 Olson Tower Drawing

CONTRACT DOCUMENTS

For the Construction of

KIMBALL STREET RESERVOIR REHABILITATION AND PINE STREET RESERVOIR DEMOLITION

FOR THE

UTILITIES DEPARTMENT OF GRAND ISLAND, NEBRASKA

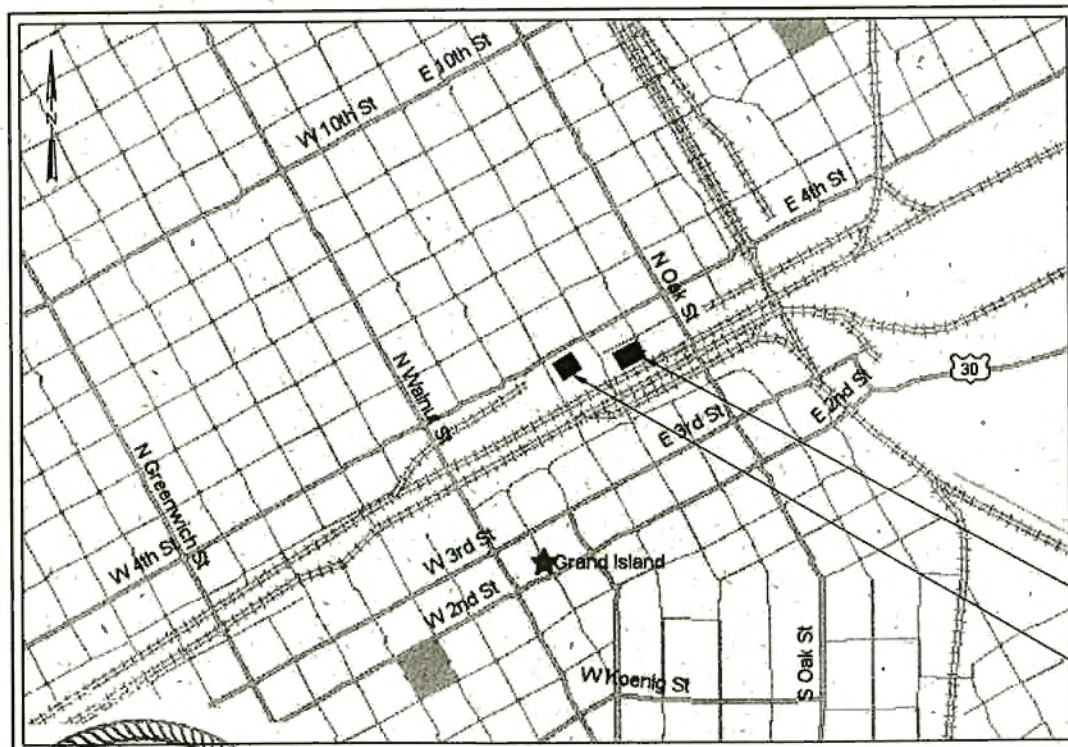

INDEX TO DRAWINGS

GENERAL		
SHEET NO.	DRAWING NO.	TITLE
1	G-1	TITLE SHEET AND INDEX TO DRAWINGS
2	G-2	STRUCTURAL NOTES
PINE STREET RESERVOIR		
3	1-D-1	DEMOLITION PLAN AND NOTES
4	1-D-2	DEMOLITION SECTIONS
KIMBALL STREET RESERVOIR		
5	2-D-1	DEMOLITION PLAN AND NOTES
6	2-D-2	DEMOLITION SECTIONS
7	2-C-1	CIVIL SITE IMPROVEMENTS & TRAFFIC CONTROL
8	2-S-1	STRUCTURAL PLAN
9	2-S-2	STRUCTURAL SECTIONS AND DETAILS
10	2-S-3	STRUCTURAL SECTIONS AND DETAILS
11	SD-1	STRUCTURAL STANDARD DETAILS
12	SD-2	STRUCTURAL STANDARD DETAILS

KIMBALL STREET RESERVOIR

PINE STREET RESERVOIR

PROJECT LOCATION

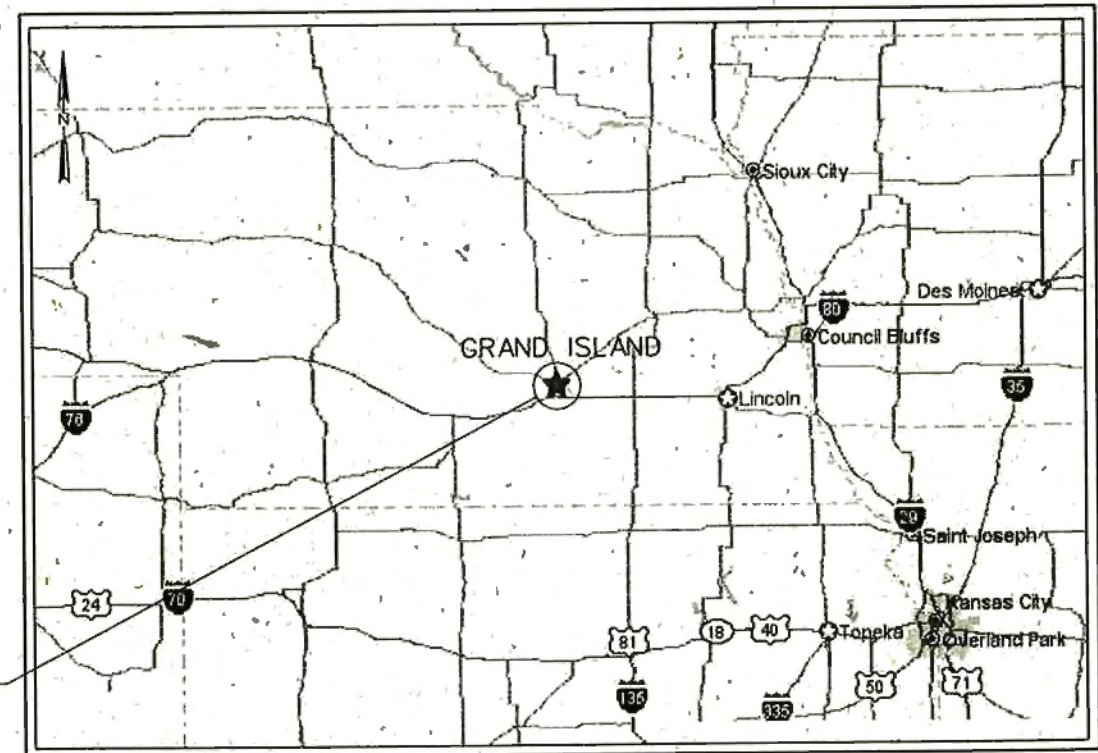

NO.	DATE	REVISION	BY	APVD

VERIFY SCALE
BAR IS ONE INCH ON ORIGINAL DRAWING.
IF NOT ONE INCH ON THIS SHEET, ADJUST SCALES ACCORDINGLY.



KIMBALL STREET RESERVOIR REHABILITATION
AND PINE STREET RESERVOIR DEMOLITION
FOR THE
UTILITIES DEPARTMENT OF GRAND ISLAND, NEBRASKA

GENERAL
TITLE SHEET AND INDEX TO DRAWINGS

SHEET 1
DWG G-1
DATE JUNE 2003
PROJ 171243.01.02

FILENAME: ksg001.dlv

PLOT DATE: 23-JUN-2003

PLOT TIME: 12:48:43

GENERAL STRUCTURAL NOTES

LOADS:

1. ALL MATERIALS AND WORKMANSHIP SHALL CONFORM TO THE UNIFORM BUILDING CODE, 1987 EDITION (U.B.C.) AS AMENDED BY THE STATE OF NEBRASKA AND LOCAL AGENCIES.

2. **LOADS:**

ROOFING DL (WITH ALLOWANCE FOR FUTURE SOIL COVER) = 220 PSF
 ROOF LIVE LOAD = 50 PSF
 ROOF SNOW LOAD = 30 PSF PLUS DRIFTING
 UBC WIND PRESSURE = 85 MPH WIND SPEED EXPOSURE C, I=1.15
 UBC SEISMIC ZONE = 1, I=1.25, S=SD

GENERAL:

- FOR ABBREVIATIONS NOT LISTED, SEE "ABBREVIATIONS FOR USE ON DRAWINGS AND TEXT", PUBLISHED BY THE AMERICAN NATIONAL STANDARDS INSTITUTE INC. (ANSI).
- STANDARD DETAILS (XXXX) AS SHOWN ON THE DRAWINGS ARE INTENDED TO BE TYPICAL AND SHALL APPLY TO ALL SIMILAR SITUATIONS OCCURRING ON THE PROJECT, WHETHER OR NOT THEY ARE KEYED IN EACH LOCATION. CONSULT THE ENGINEER FOR REVIEW PRIOR TO CONSTRUCTION.
- NO STRUCTURAL MEMBERS SHALL BE CUT FOR PIPES, DUCTS, ETC, UNLESS SPECIFICALLY DETAILED OR APPROVED IN WRITING BY THE ENGINEER.
- VISITS TO THE JOB SITE BY THE ENGINEER TO OBSERVE THE CONSTRUCTION DO NOT IN ANY WAY MEAN THAT THEY ARE GUARANTORS OF THE CONSTRUCTOR'S WORK, NOR RESPONSIBLE FOR COMPREHENSIVE OR SPECIAL INSPECTIONS, COORDINATION, SUPERVISION, NOR SAFETY AT THE JOB SITE.
- SPECIAL INSPECTION IS REQUIRED IN ACCORDANCE WITH UBC SECTION 1701 ON THE FOLLOWING PORTIONS OF THE WORK:
 CONCRETE
 REINFORCING STEEL
 STRUCTURAL WELDING
 ANCHORS, EMBEDS AND BOLTS INSTALLED IN CONCRETE

FORMWORK, SHORING AND BRACING:

- CONSTRUCTION SHORING AND BRACING OF FORMWORK SHALL BE IN ACCORDANCE WITH CHAPTER 4 OF ACI 301 "SPECIFICATIONS FOR STRUCTURAL CONCRETE FOR BUILDINGS" AND ACI 347 "RECOMMENDED PRACTICE FOR CONCRETE FORMWORK".
- THE STRUCTURES SHOWN ON THE DRAWINGS HAVE BEEN DESIGNED FOR STABILITY UNDER FINAL CONDITIONS ONLY. THESE PLANS DO NOT INCLUDE THE NECESSARY COMPONENTS OR EQUIPMENT FOR THE STRUCTURE'S STABILITY DURING CONSTRUCTION. THE CONTRACTOR IS RESPONSIBLE FOR ALL WORK RELATING TO CONSTRUCTION ERECTION METHODS, BRACING, SHORING, RIGGING, GUYS, SCAFFOLDING, FORMWORK, AND OTHER WORK AIDS REQUIRED TO SAFELY PERFORM THE WORK SHOWN.
- TEMPORARY SHORING SHALL REMAIN IN PLACE UNTIL ELEVATED CONCRETE FLOOR OR ROOF DECKS HAVE REACHED 28 DAY DESIGN STRENGTH AS DETERMINED BY CYLINDER BREAKS.

CONCRETE:

- ALL CAST-IN-PLACE CONCRETE SHALL HAVE A MINIMUM 28 DAY COMPRESSIVE STRENGTH OF 5000 PSI, EXCEPT WHERE SPECIFICALLY INDICATED OTHERWISE.
- REINFORCING STEEL SHALL CONFORM TO ASTM A615, GRADE 60, UNLESS INDICATED OTHERWISE. FABRICATION AND PLACEMENT OF REINFORCING STEEL SHALL BE IN ACCORDANCE WITH CRSI MSP-1 "MANUAL OF STANDARD PRACTICE" AND ACI 301 "SPECIFICATIONS FOR STRUCTURAL CONCRETE FOR BUILDING".
- CONTRACTOR SHALL SUBMIT ALL CONSTRUCTION JOINT LOCATIONS FOR REVIEW BY THE ENGINEER. ADDITIONAL CONSTRUCTION JOINT LOCATIONS, AS REQUIRED FOR CONSTRUCTION, SHALL BE SUBMITTED FOR REVIEW. REFER TO SECTION 03300 "CAST-IN-PLACE CONCRETE" FOR MAXIMUM JOINT SPACING.
- CONTINUOUS WATERSTOP AS SPECIFIED SHALL BE INSTALLED IN ALL CONSTRUCTION JOINTS IN WALLS OF WATER HOLDING BASINS, EXCEPT WHERE SPECIFICALLY NOTED OTHERWISE.
- THE CONTRACTOR SHALL COORDINATE PLACEMENT OF ALL OPENINGS, CURBS, DOWELS, SLEEVES, CONDUITS, BOLTS AND INSERTS PRIOR TO PLACEMENT OF CONCRETE.
- NO ALUMINUM CONDUIT OR PRODUCTS CONTAINING ALUMINUM OR ANY OTHER MATERIAL INJURIOUS TO THE CONCRETE SHALL BE EMBEDDED IN THE CONCRETE.

CONCRETE REINFORCING

- CLEARANCE FOR REINFORCEMENT BARS, UNLESS SHOWN OTHERWISE, SHALL BE:
 • WHEN PLACED ON GROUND: 3"
 • ALL OTHER CONCRETE SURFACES:
 #5 BAR OR SMALLER 1 1/2"
 #6 BAR OR LARGER 2"
- REFER TO WALL CORNER AND WALL INTERSECTION REINFORCING DETAILS (3303) IN GENERAL, THE TYPICAL HORIZONTAL WALL REINFORCING SHALL BE EXTENDED INTO THE CONNECTING WALLS AND HOOKED/LAPPED ON OPPOSITE THE FACE.
- ALL BENDS, UNLESS OTHERWISE SHOWN, SHALL BE A 90 DEGREE STANDARD HOOK AS DEFINED IN LATEST EDITION OF ACI 318.
- VERTICAL WALL BARS SHALL BE LAPPED WITH DOWELS FROM WALL BELOW AND EXTENDED INTO THE TOP FACE OF ROOF SLABS AND LAPPED WITH TOP SLAB REINFORCEMENT.
- UNLESS INDICATED OTHERWISE, CONTRACTOR MAY SPLICE CONTINUOUS SLAB OR LONGITUDINAL BEAM BARS AT LOCATIONS OF HIS CHOOSING, EXCEPT THAT TOP BAR SPLICES SHALL BE LOCATED AT MIDSPAN AND BOTTOM BAR SPLICES SHALL BE LOCATED AT SUPPORTS. ALL REINFORCEMENT BENDS AND LAPS, UNLESS OTHERWISE NOTED, SHALL SATISFY THE FOLLOWING MINIMUM REQUIREMENTS:

CONCRETE DESIGN STRENGTH = 4,000 PSI		GRADE 60 REINFORCING STEEL									
BAR SIZE		#3	#4	#5	#6	#7	#8	#9	#10	#11	
LAP SPLICE LENGTH											
SPACING < 6"	TOP BAR *	1'-4"	2'-0"	3'-0"	4'-0"	5'-10"	6'-6"	7'-7"	8'-6"	9'-5"	
	OTHER BAR	1'-4"	1'-7"	2'-4"	3'-1"	4'-8"	5'-2"	5'-10"	6'-7"	7'-3"	
SPACING ≥ 6"	TOP BAR *	1'-4"	1'-8"	2'-0"	2'-5"	3'-6"	4'-0"	5'-0"	6'-2"	7'-6"	
	OTHER BAR	1'-4"	1'-4"	1'-7"	1'-10"	2'-9"	3'-1"	3'-10"	4'-9"	5'-8"	
EMBEDMENT LENGTH											
SPACING < 6"	TOP BAR *	1'-0"	1'-7"	2'-4"	3'-1"	4'-6"	5'-2"	5'-10"	6'-7"	7'-3"	
	OTHER BAR	1'-0"	1'-3"	1'-9"	2'-5"	3'-6"	4'-0"	4'-8"	5'-1"	5'-7"	
SPACING ≥ 6"	TOP BAR *	1'-0"	1'-3"	1'-7"	1'-10"	2'-6"	3'-1"	3'-10"	4'-9"	5'-8"	
	OTHER BAR	1'-0"	1'-0"	1'-3"	1'-5"	2'-1"	2'-5"	3'-0"	3'-6"	4'-5"	

* TOP BARS SHALL BE DEFINED AS ANY HORIZONTAL BARS PLACED SUCH THAT MORE THAN 12" OF FRESH CONCRETE IS CAST IN THE MEMBER BELOW THE BAR IN ANY SINGLE POUR. HORIZONTAL WALL BARS ARE CONSIDERED TOP BARS.

- PROVIDE ADDITIONAL REINF AT ALL OPENINGS IN REINFORCED CONCRETE SLABS AND WALLS IN ACCORDANCE WITH (3301)

ABBREVIATIONS:

AB ANCHOR BOLT	FD FLOOR DRAIN	RC REINFORCED CONCRETE
AHR ANCHOR	FDN FOUNDATION	REINF REINFORCE
AL ALUMINUM	FG FINISHED GRADE	RST REINFORCING STEEL
ALTN ALTERNATE	FTG FOOTING	
APVD APPROVED	GALV GALVANIZED (HOT DIP)	SIM SIMILAR SPECIFICATIONS
BOT BOTTOM	GVL GRAVEL	SQ SQUARE
BF BOTTOM FACE	HAS HEADED ANCHOR STUD	STD STANDARD
BM BEAM	HDR HEADER	STIF STIFFENER
BRG BEARING	HORIZ HORIZONTAL	STL STEEL
C TO C CENTER TO CENTER	I.F. INSIDE FACE	STR STRAIGHT STRUCTURE
CJ CONSTRUCTION JOINT	LNTL LONGITUDINAL	SYMM SYMMETRICAL
CL CENTER LINE	MB MAXIMUM MACHINE BOLT	TC TOP AND BOTTOM
CLR CLEARANCE, CLEAR	MIN MINIMUM	TOP OF CONCRETE, TOP OF CURB
COL COLUMN	NIC NOT IN CONTRACT	TF TOP FACE
CONC CONCRETE	NTS NOT TO SCALE	THK THICK
CONN CONNECTION	OC ON CENTER	TRANSV TRANSVERSE
CONT CONTINUOUS	O.F. OUTSIDE FACE	TST TOP OF STEEL
CTR CENTER	O TO O OUT TO OUT	TW TOP OF WALL
CTRD CENTERED	OPNG OPENING	TYP TYPICAL
d PENNY (NAIL SIZE)	PJF PREMOLDED JOINT FILLER	VERT VERTICAL
DBA DEFORMED BAR ANCHOR	PLYWD PLYWOOD	WS WATERSTOP OR WATER SURFACE
DIA DIAMETER	PRCST PRECAST	WWF WELDED WIRE FABRIC
DIR DIRECTION	P PILASTER	
DWG DRAWING		
EA EACH		
EF EACH FACE		
EL ELEVATION		
EQL SPACED		
EQ SPACED		
EW EACH WAY		
EXP JT EXPANSION JOINT		
EXST EXISTING		

NOTE:

FOR ABBREVIATIONS NOT LISTED, SEE "ABBREVIATIONS FOR USE ON DRAWINGS AND TEXT", PUBLISHED BY THE AMERICAN NATIONAL STANDARDS INSTITUTE INC. (ANSI)

LEGEND

	AREA TO BE DEMOLISHED OR REMOVED
	EXISTING STRUCTURE
	CONCRETE
	CONCRETE
	MASONRY (PLAN)
	MASONRY (SECTION)
	ROOFING AND INSULATION



DSGN	S.PATTERSON						VERIFY SCALE
DR	C.SCHNEE						BAR IS ONE INCH ON ORIGINAL DRAWING.
CHK	D.SIMON						IF NOT ONE INCH ON THIS SHEET, ADJUST SCALES ACCORDINGLY.
APVD	D.SIMON	NO.	DATE	REVISION	BY	APVD	



KIMBALL STREET RESERVOIR REHABILITATION AND PINE STREET RESERVOIR DEMOLITION FOR THE UTILITIES DEPARTMENT OF GRAND ISLAND, NEBRASKA

GENERAL STRUCTURAL NOTES

SHEET 2
DWG G-2
DATE JUNE 2003
PROJ 171243.01.02

THIS DOCUMENT AND THE IDEAS AND DESIGNS INCORPORATED HEREIN AS AN INSTRUMENT OF PROFESSIONAL SERVICE, IS THE PROPERTY OF CH2MHILL AND IS NOT TO BE USED, IN WHOLE OR IN PART, FOR ANY OTHER PROJECT WITHOUT THE WRITTEN AUTHORIZATION OF CH2MHILL.

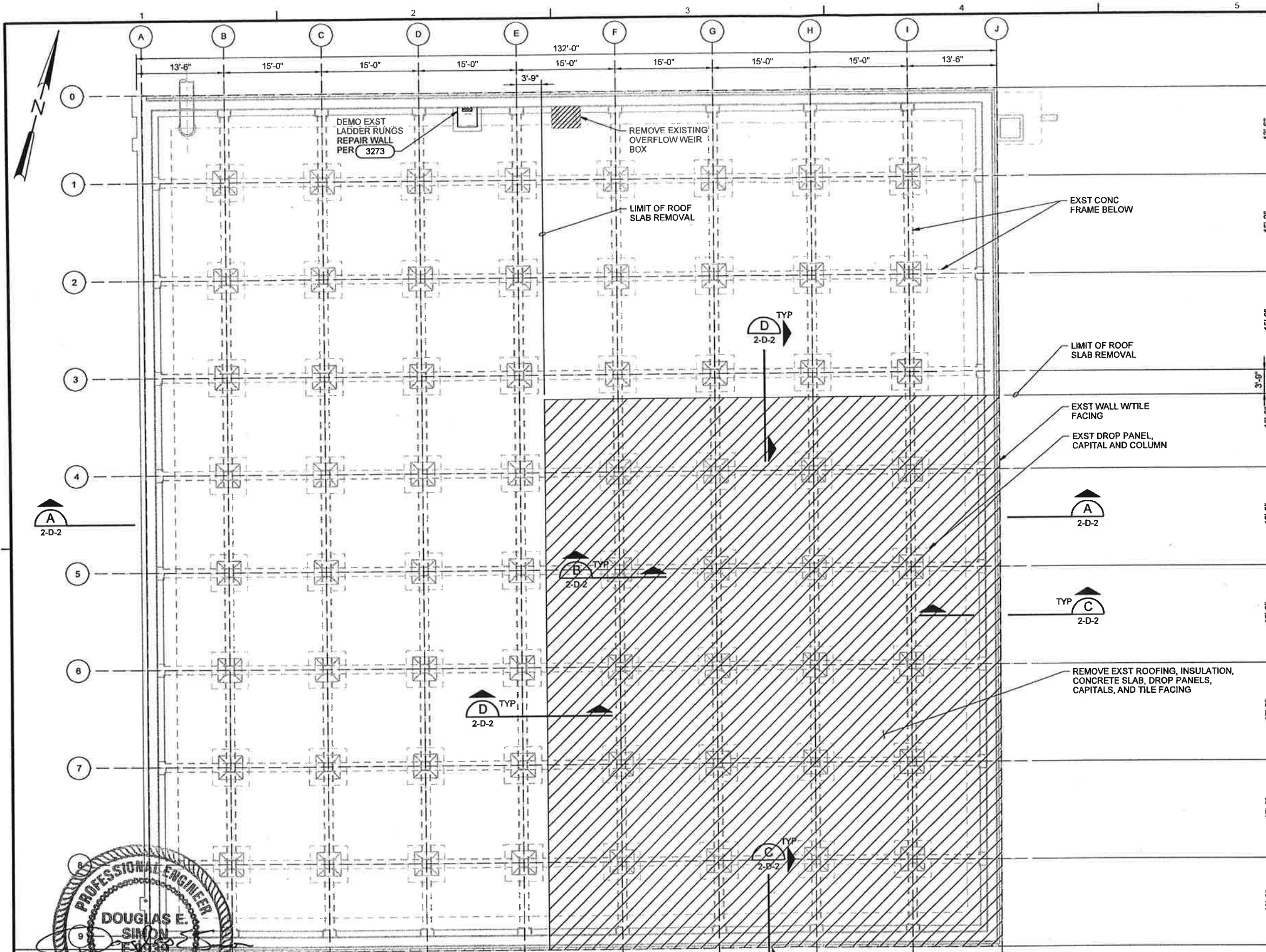

NOTES:

1. THE CONTRACTOR SHALL REMAIN RESPONSIBLE FOR THE MEANS AND METHODS OF SHORING, DEMOLITION, AND CONSTRUCTION OF THE FACILITIES PER THE CONTRACT DOCUMENTS. OVERALL CONSTRUCTION PERSONNEL SAFETY, EQUIPMENT PROTECTION, AND CONSTRUCTION PROCESSES SHALL REMAIN THE RESPONSIBILITY OF THE CONTRACTOR.
2. EXISTING DESIGN DOCUMENTS ARE AVAILABLE FROM THE OWNER FOR A FEE AS DETAILED IN THE SPECIFICATIONS.
3. UNLESS INDICATED OTHERWISE, THE CONTRACTOR SHALL PROTECT INSTRUMENTATION, PIPING, OR OTHER APPURTENANCES PRIOR TO DEMOLITION ACTIVITIES AS FOLLOWS:
 - KIMBALL STREET RESERVOIR: PIPING AND APPURTENANCES, INSTRUMENTATION, ROOFING, BRICK FACING, AND VENTS
4. ANY ITEMS LISTED ABOVE AFFECTED BY THE DEMOLITION ACTIVITIES, THAT ARE NOT INDICATED AS BEING REMOVED, SHALL BE TEMPORARILY RELOCATED AND REINSTALLED. ANY ITEMS DAMAGED BY ACTIVITIES SHALL BE REPLACED IN KIND.
5. THE CONTRACTOR SHALL PROVIDE ALL SECURITY TO PREVENT INTRUSION TO RESERVOIRS DURING DEMOLITION AND CONSTRUCTION ACTIVITIES.
6. THE CONTRACTOR SHALL SHORE ALL SLABS, WALLS, COLUMNS, AND OTHER ELEMENTS CONTINUOUSLY DURING DEMOLITION AND CONSTRUCTION. RESERVOIRS ARE NOT STABLE ONCE TOP SLABS AND OR TIE BEAM ELEMENTS ARE REMOVED. SHORING AND BRACING DESIGN SHALL BE DEVELOPED AND STAMPED BY A PROFESSIONAL ENGINEER REGISTERED IN THE STATE OF NEBRASKA. SHORING AND BRACING SHALL BE DESIGNED TO RESIST LOADS INCLUDING CONSTRUCTION TRAFFIC, DEAD LOAD, SOIL, WIND, SEISMIC, SNOW, AND LIVE LOADS. SHORING AND BRACING MAY ONLY BE REMOVED ONCE THE FOLLOWING ACTIVITIES ARE COMPLETE:
 - KIMBALL STREET RESERVOIR: REINFORCED CONCRETE TOP SLAB IS IN PLACE AND HAS REACHED A MINIMUM COMPRESSIVE STRENGTH OF 4000 PSI.
7. CARE SHALL BE EXERCISED TO NOT DAMAGE ADJACENT BUILDINGS AT EITHER RESERVOIR LOCATION. PRIOR TO BEGINNING DEMOLITION WORK, EXISTING WALLS, WINDOWS, ROOFING, AND ANCILLARY PORTIONS OF ADJACENT BUILDINGS SHALL BE PROTECTED BY PLYWOOD OR SIMILAR MATERIALS. ANY DAMAGE TO ADJACENT STRUCTURES SHALL BE REPAIRED AT THE EXPENSE OF THE CONTRACTOR TO THE SATISFACTION OF THE OWNER.
8. SHOULD THE CONTRACTOR OBSERVE ADDITIONAL AREAS DAMAGED, CRACKED, OR OTHERWISE IN POOR CONDITION, NOTIFY THE OWNER FOR INSPECTION. (KIMBALL STREET RESERVOIR ONLY)
9. SHOULD THE CONTRACTOR OBSERVE ADDITIONAL CRACKING OR MOVEMENT OF THE RESERVOIR PORTIONS TO REMAIN DUE TO DEMOLITION OR CONSTRUCTION ACTIVITIES, DISCONTINUE WORK AND NOTIFY THE OWNER.
10. FIELD VERIFY ALL EXISTING CONDITIONS AND DIMENSIONS. REPORT ANY SIGNIFICANT DISCREPANCIES TO THE ENGINEER PRIOR TO BEGINNING WORK.
11. THE CONTRACTOR SHALL BE RESPONSIBLE FOR MAINTAINING ALL SAFETY STANDARDS DURING AND AFTER DEMOLITION AND FOR THE STABILITY OF PARTIALLY OR WHOLLY DEMOLISHED PORTIONS OF STRUCTURES.
12. ALL CONSTRUCTION AND DEMOLITION RELATED PERMITS SHALL BE THE RESPONSIBILITY OF THE CONTRACTOR.

PLAN
1/8"=1'-0"

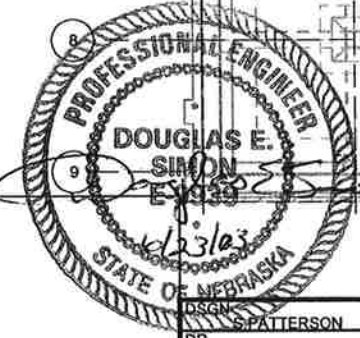

DESIGN	S. PATTERSON	NO.	DATE	REVISION	BY	APVD
DR	C. SCHNEE					
CHK	D. SIMON					
APVD	D. SIMON					

VERIFY SCALE
BAR IS ONE INCH ON ORIGINAL DRAWING.
IF NOT ONE INCH ON THIS SHEET, ADJUST SCALES ACCORDINGLY.



KIMBALL STREET RESERVOIR REHABILITATION AND PINE STREET RESERVOIR DEMOLITION FOR THE UTILITIES DEPARTMENT OF GRAND ISLAND, NEBRASKA

DEMOLITION
KIMBALL STREET RESERVOIR DEMOLITION PLAN AND NOTES

SHEET 5
DWG 2-D-1
DATE JUNE 2003
PROJ 171243.01.02

REUSE OF DOCUMENTS: THIS DOCUMENT, AND THE IDEAS AND DESIGNS INCORPORATED HEREIN, AS AN INSTRUMENT OF PROFESSIONAL SERVICE, IS THE PROPERTY OF CH2M HILL AND IS NOT TO BE USED, IN WHOLE OR IN PART, FOR ANY OTHER PROJECT WITHOUT THE WRITTEN AUTHORIZATION OF CH2M HILL. © CH2M HILL

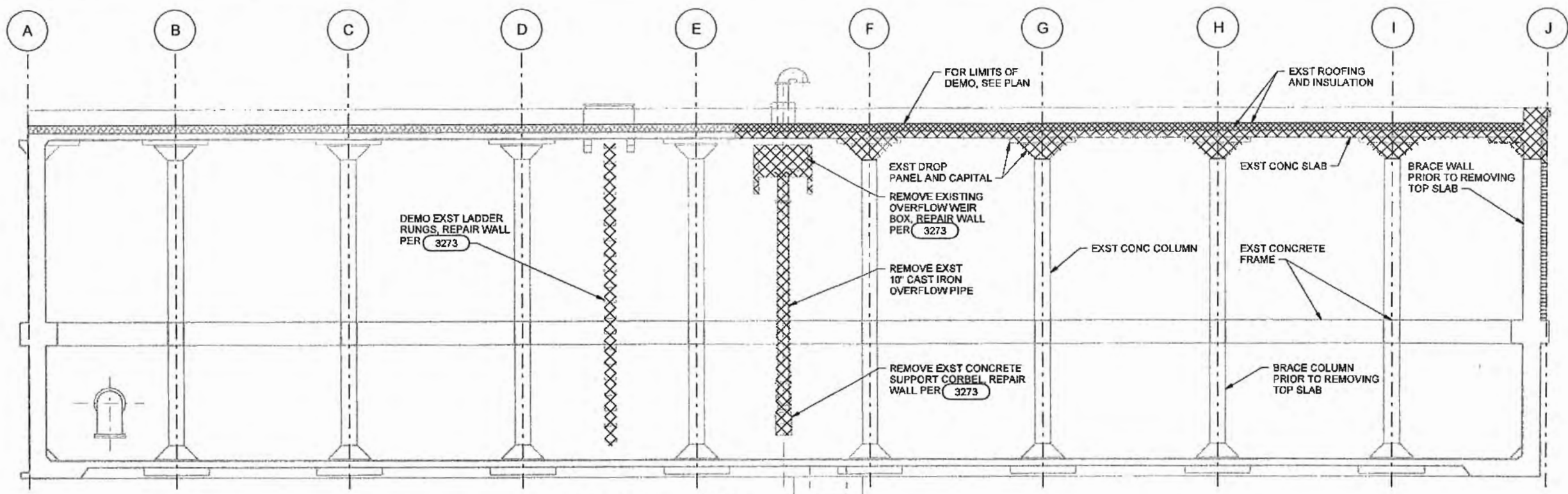

SECTION A
3/16"=1'-0" 2-D-1

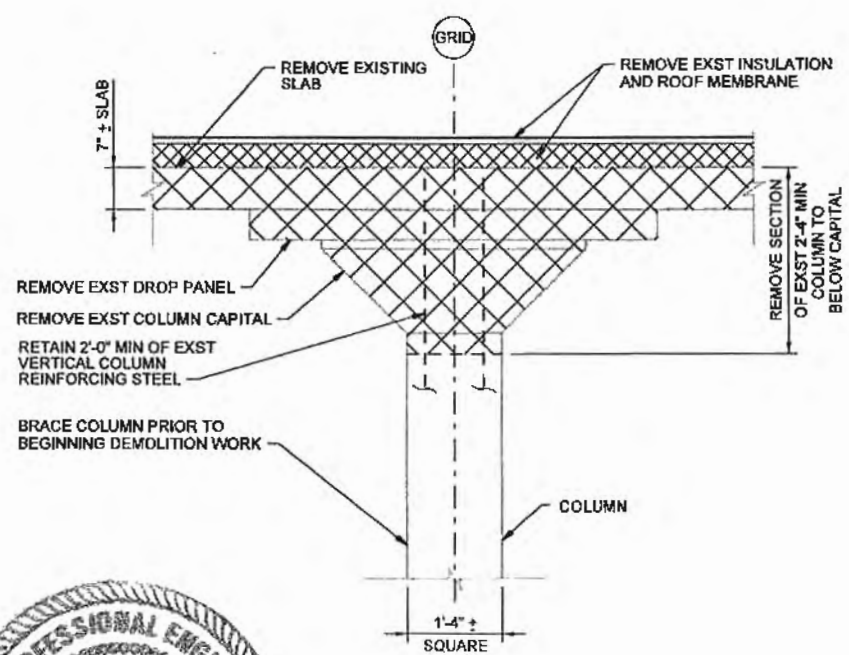

SECTION B
3/4"=1'-0" 2-D-1

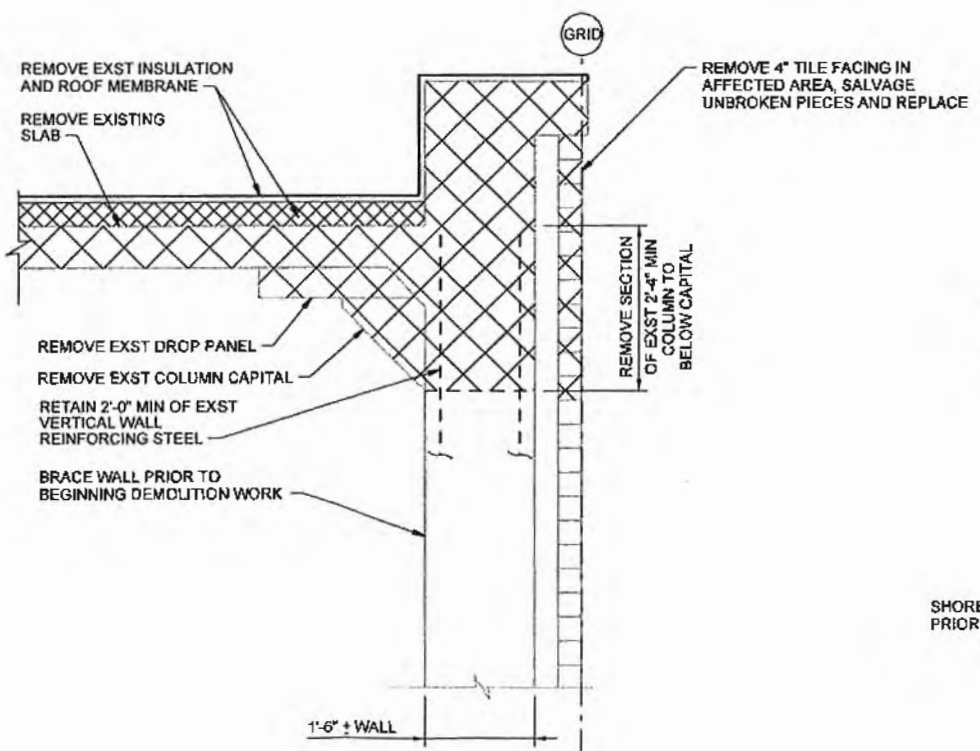

SECTION C
3/4"=1'-0" 2-D-1

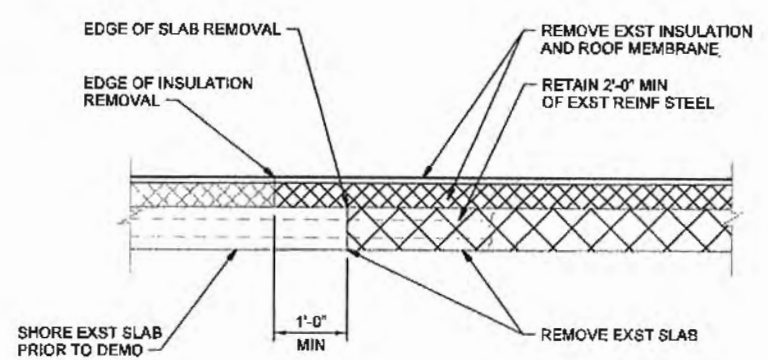

SECTION D
3/4"=1'-0" 2-D-1



DSGN	S.PATTERSON				
DR	C.SCHNEE				
CHK	D.SIMON				
APVD	D.SIMON	NO.	DATE	REVISION	BY
					APVD

VERIFY SCALE
BAR IS ONE INCH ON ORIGINAL DRAWING.
0 1"
IF NOT ONE INCH ON THIS SHEET, ADJUST SCALES ACCORDINGLY.



KIMBALL STREET RESERVOIR REHABILITATION AND PINE STREET RESERVOIR DEMOLITION FOR THE UTILITIES DEPARTMENT OF GRAND ISLAND, NEBRASKA

DEMOLITION
KIMBALL STREET RESERVOIR
DEMOLITION SECTIONS

SHEET 6
DWG 2-D-2
DATE JUNE 2003
PROJ 171243.01.02

THIS DOCUMENT AND THE IDEAS AND DESIGNS INCORPORATED HEREIN, AS AN INSTRUMENT OF PROFESSIONAL SERVICE, IS THE PROPERTY OF CH2M HILL AND IS NOT TO BE USED, IN WHOLE OR IN PART, FOR ANY OTHER PROJECT WITHOUT THE WRITTEN AUTHORIZATION OF CH2M HILL

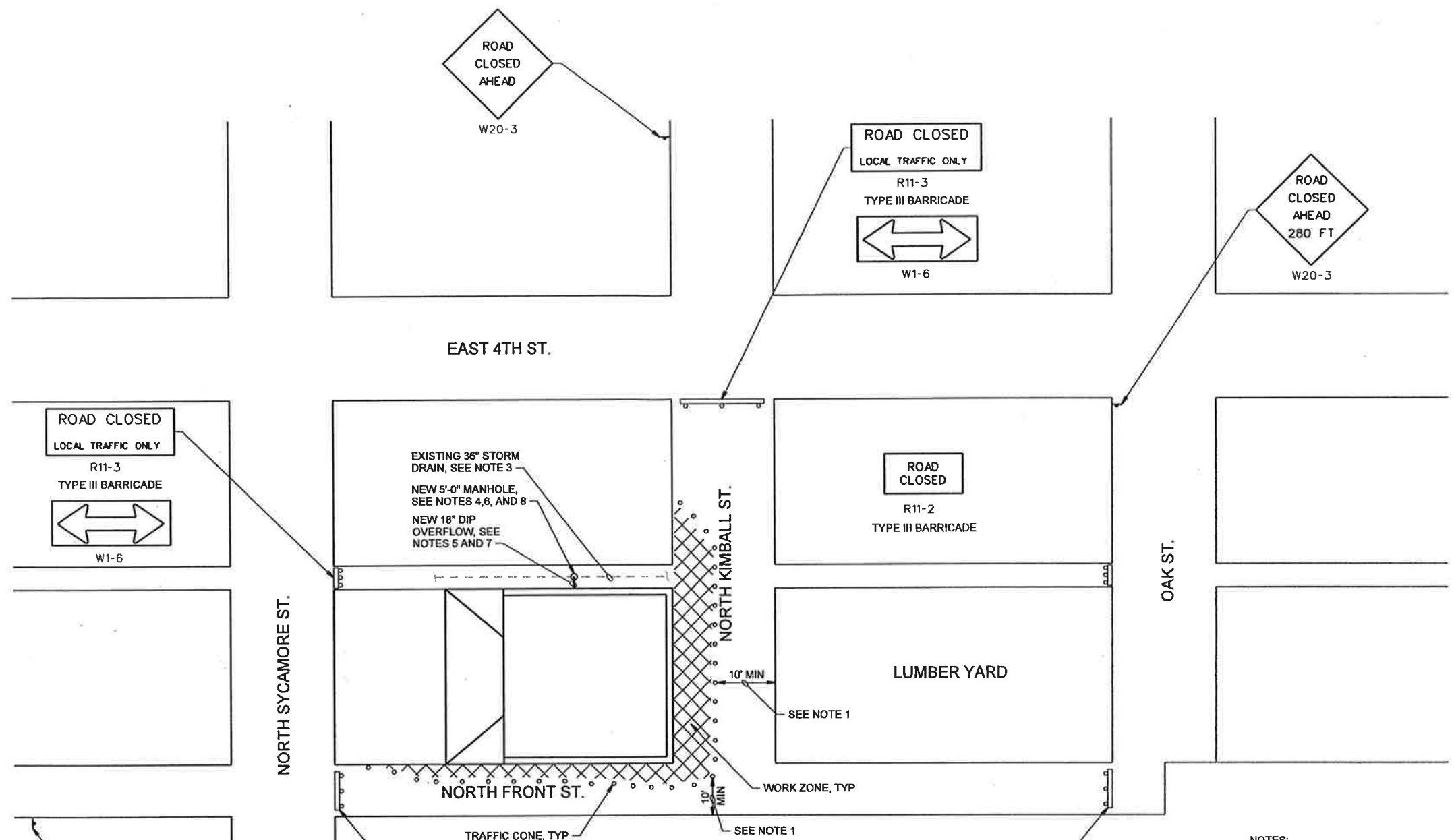

- NOTES:**
1. THE CONTRACTOR SHALL MAINTAIN ONE LANE ACCESS TO BUSINESS AT ALL TIMES, AND COORDINATE RESTRICTIONS WITH BUSINESS OWNERS.
 2. TRAFFIC CONTROL SHALL COMPLY WITH PART VI, STANDARDS AND GUIDELINES FOR TRAFFIC CONTROLS FOR STREET AND HIGHWAY CONSTRUCTION MAINTENANCE, UTILITY, AND INCIDENT MANAGEMENT OPERATIONS, PART VI OF THE MANUAL ON UNIFORM TRAFFIC CONTROL DEVICES (MUTCD).
 3. CONTRACTOR TO VERIFY LOCATION OF EXISTING 36" STORM IN ALLEY NORTH OF RESERVOIR, PRIOR TO START OF WORK.
 4. CONNECTION OF NEW 18" OVERFLOW RELIEF PIPE TO EXISTING 36" STORM AT NEW 5'-0" MANHOLE.
 5. 18" DIP TO HAVE 2% SLOPE TO NEW MANHOLE.
 6. SET NEW MANHOLE RIM AT EXISTING ALLEY ELEVATION.
 7. LENGTH OF 18" DIP ESTIMATED TO BE 15'-0" ±.
 8. CONTRACTOR TO INSTALL 18" FLAP VALVE OR APPROVED EQUAL AT OUTLET OF OVERFLOW PIPE TO PREVENT RODENT ENTRY INTO OVERFLOW PIPE DURING PERIODS WHEN NO FLOW THROUGH OVERFLOW PIPE.

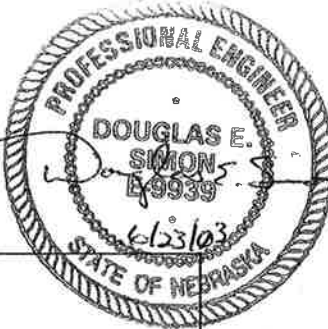

DSGN	B. TORRES				
DR	C. SCHNEE				
CHK	D. SIMON				
APVD	D. SIMON	NO.	DATE	REVISION	BY

VERIFY SCALE
 BAR IS ONE INCH ON ORIGINAL DRAWING.
 0" ——— 1"
 IF NOT ONE INCH ON THIS SHEET, ADJUST SCALES ACCORDINGLY.



KIMBALL STREET RESERVOIR REHABILITATION AND PINE STREET RESERVOIR DEMOLITION FOR THE UTILITIES DEPARTMENT OF GRAND ISLAND, NEBRASKA

CIVIL
**PINE STREET RESERVOIR
 CIVIL SITE IMPROVEMENTS
 AND TRAFFIC CONTROL**

SHEET 7
DWG 2-C-1
DATE JUNE 2003
PROJ 171243.01.02

REUSE OF DOCUMENTS: CH2M HILL AND IS NOT TO BE USED, IN WHOLE OR IN PART, FOR ANY OTHER PROJECT WITHOUT THE WRITTEN AUTHORIZATION OF CH2M HILL. © CH2M HILL

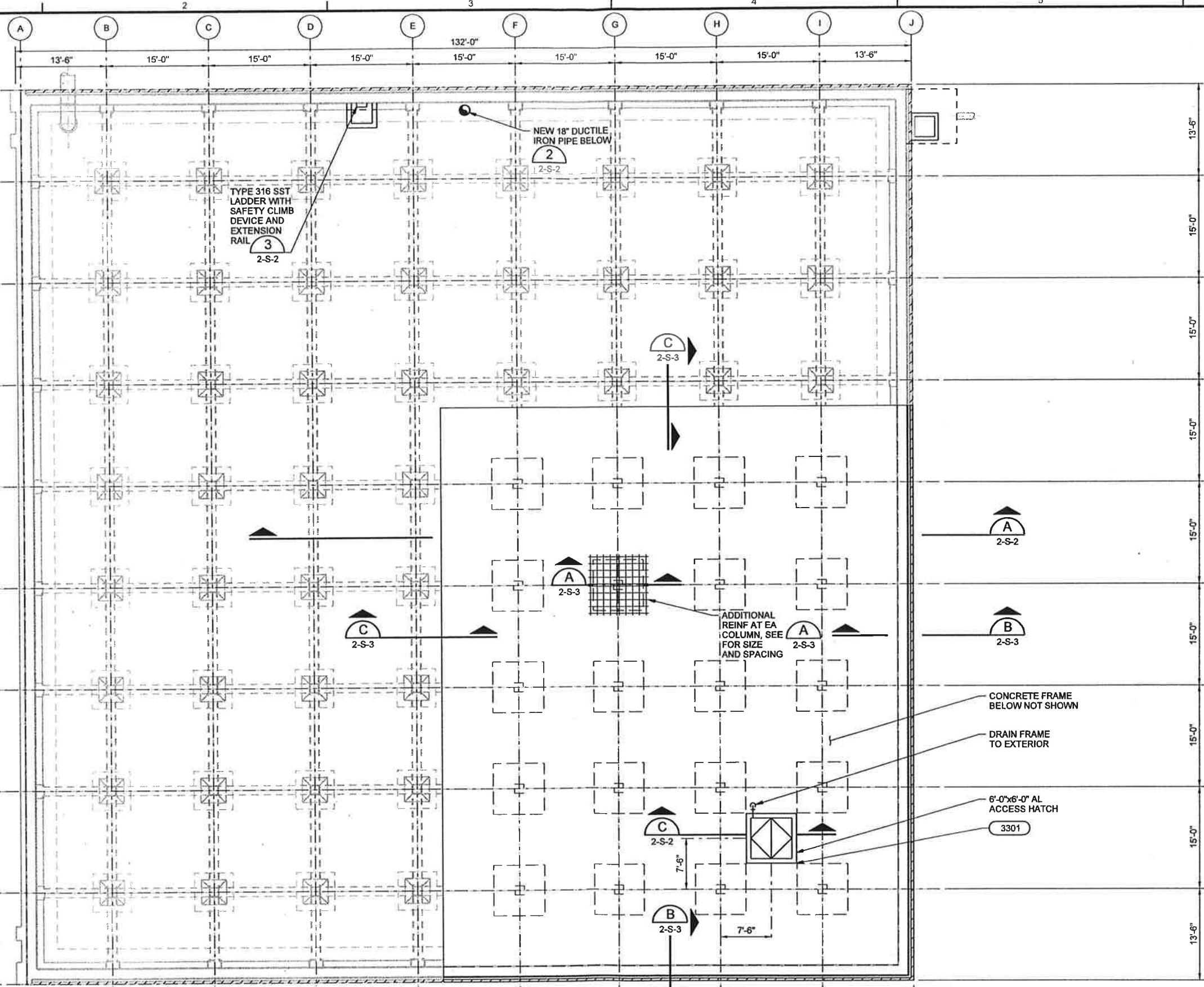

PLAN
1/8"=1'-0"

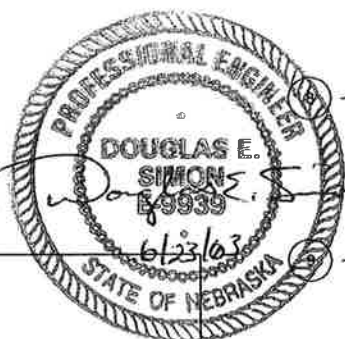

DSGN	S. PATTERSON				
DR	C. SCHNEE				
CHK	D. SIMON				
APVD	D. SIMON	NO.	DATE	REVISION	BY

VERIFY SCALE
BAR IS ONE INCH ON ORIGINAL DRAWING.
0" = 1"
IF NOT ONE INCH ON THIS SHEET, ADJUST SCALES ACCORDINGLY.



KIMBALL STREET RESERVOIR REHABILITATION AND PINE STREET RESERVOIR DEMOLITION FOR THE UTILITIES DEPARTMENT OF GRAND ISLAND, NEBRASKA

STRUCTURAL
KIMBALL STREET RESERVOIR
STRUCTURAL PLAN

SHEET 8
DWG 2-S-1
DATE JUNE 2003
PROJ 171243.01.02

REUSE OF DOCUMENTS: THIS DOCUMENT, AND THE IDEAS AND DESIGNS INCORPORATED HEREIN, AS AN INSTRUMENT OF PROFESSIONAL SERVICE, IS THE PROPERTY OF CH2M HILL AND IS NOT TO BE USED, IN WHOLE OR IN PART, FOR ANY OTHER PROJECT WITHOUT THE WRITTEN AUTHORIZATION OF CH2M HILL.

See section 3740 of RFB

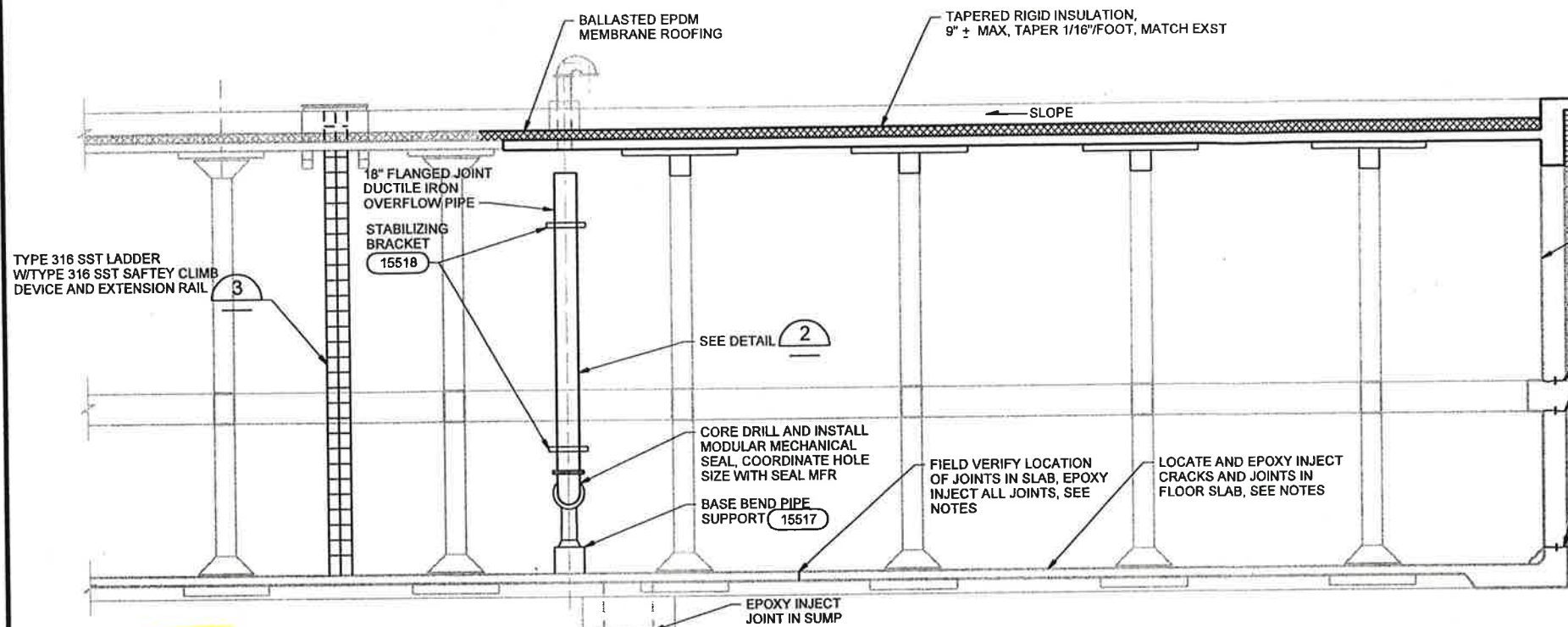

NOTES:

1. THE KIMBALL STREET RESERVOIR LEAKS AT A RATE OF APPROXIMATELY 70,000 GALLONS PER DAY. THE INTENT OF THESE DOCUMENTS IS TO REDUCE THE LEAKAGE TO AN AMOUNT OF NOT MORE THAN 2,870 GALLONS PER DAY.
2. PRIOR TO BEGINNING THE EPOXY INJECTION WORK, THE CONTRACTOR SHALL PRESSURE WASH AND THOROUGHLY CLEAN ALL WALL AND SLAB SURFACES BELOW THE ELEVATION OF THE OVERFLOW WEIR.
3. AFTER CLEANING IS COMPLETE, THE CONTRACTOR SHALL INSTALL LIGHTING SUCH THAT THE EPOXY INJECTION CREW AND THE OWNER (OR OWNERS REPRESENTATIVE) MAY INSPECT THE SURFACES AND JOINTS.
4. AS SPECIFIED IN SECTION 03740, THE CONTRACTORS PRICE SHALL INCLUDE 2500 FEET OF EPOXY INJECTION WORK. INJECTION WORK OVER OR UNDER THAT AMOUNT SHALL BE HANDLED ON A UNIT COST BASIS AS DETAILED IN THE SPECIFICATIONS.
5. THE FOLLOWING ITEMS SHALL BE EPOXY INJECTED:
 - ALL CONSTRUCTION JOINTS IN THE WALLS AND FLOOR SLAB BELOW THE ELEVATION OF THE TOP OF THE OVERFLOW LAUNDER
 - ALL PIPE OR OTHER PENETRATIONS BELOW THE ELEVATION OF THE TOP OF THE OVERFLOW LAUNDER
 - ANY VISIBLE CRACKS IN WALLS OR FLOOR SLAB BENEATH THE ELEVATION OF THE TOP OF THE OVERFLOW LAUNDER

SECTION A
3/16"=1'-0" 2-S-1

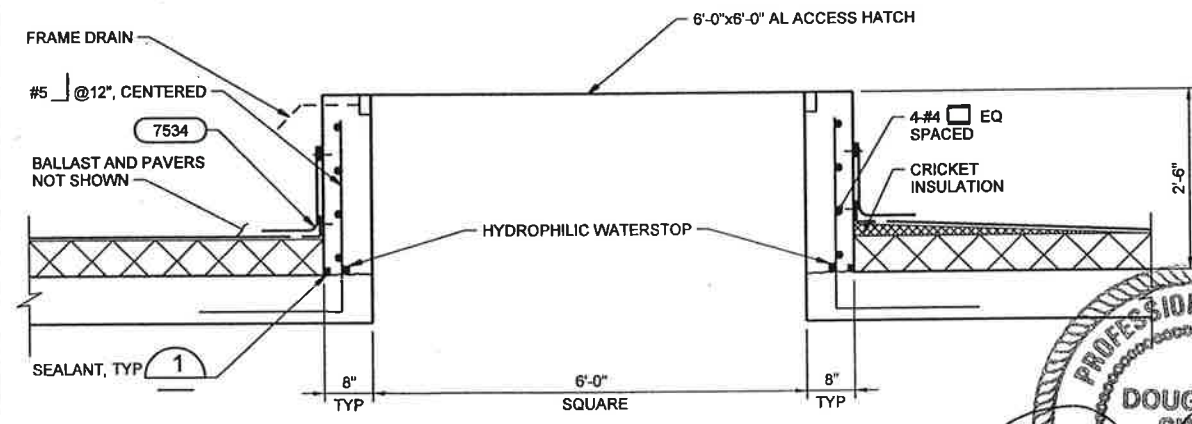

SECTION C
3/4"=1'-0" 2-S-1

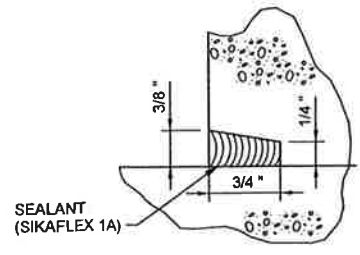

DETAIL 1
1"=1" 1-S-1

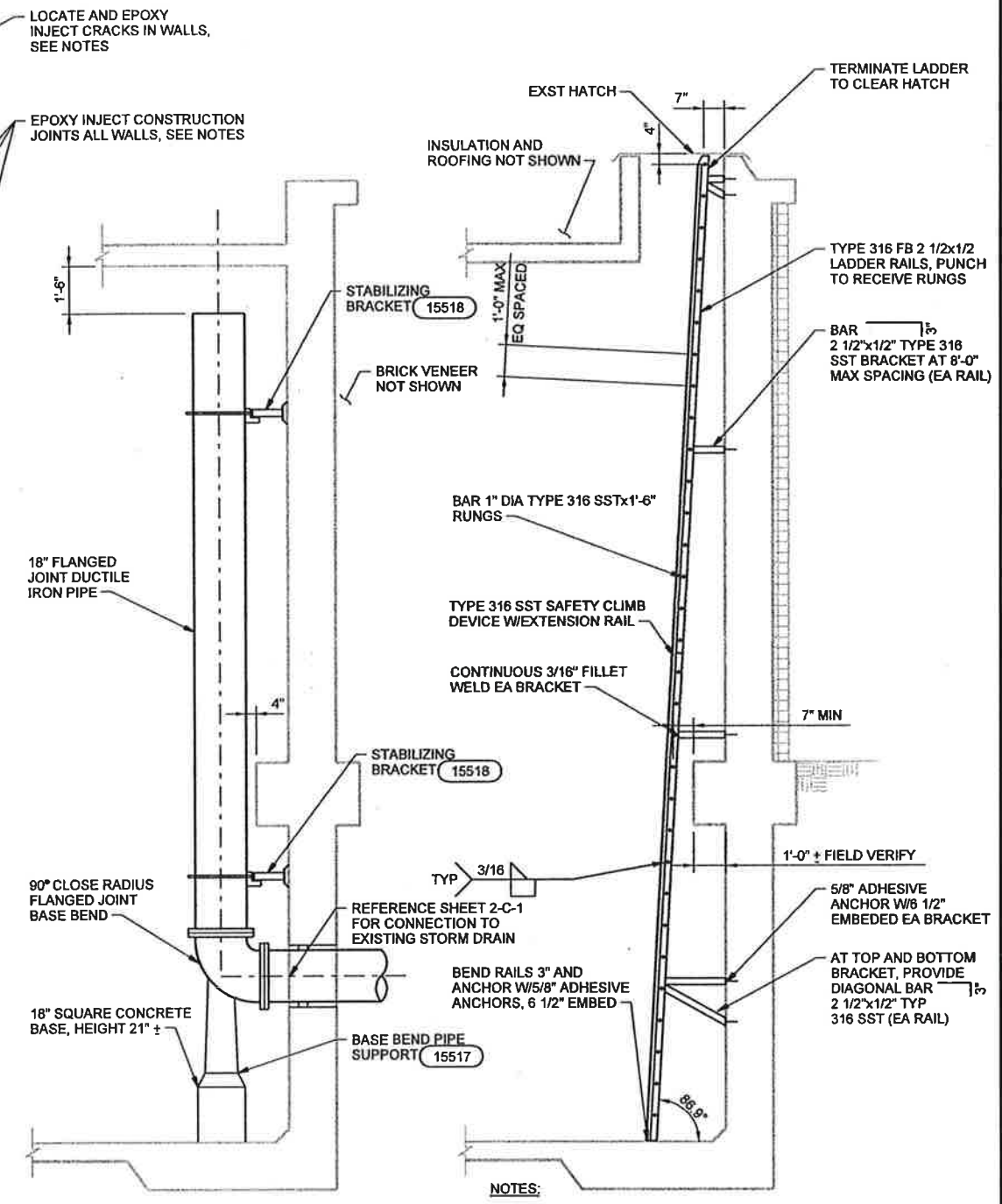

DETAIL 2
3/8"=1'-0" 2-S-1

DETAIL 3
3/8"=1'-0" 2-S-1

NOTES:
FIELD VERIFY ALL DIMENSIONS PRIOR TO FABRICATION. PROVIDE 7" MIN FROM CENTER OF RUNG TO ANY CONCRETE SURFACE. ADJUST ANGLE OF LADDER ACCORDINGLY.

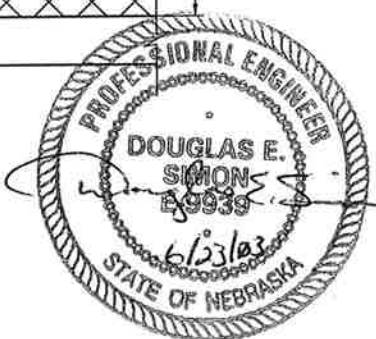

DSGN	S.PATTERSON	NO.	DATE	REVISION	BY	APVD
DR	C.SCHNEE					
CHK	D.SIMON					
APVD	D.SIMON					

VERIFY SCALE
BAR IS ONE INCH ON ORIGINAL DRAWING.
IF NOT ONE INCH ON THIS SHEET, ADJUST SCALES ACCORDINGLY.



KIMBALL STREET RESERVOIR REHABILITATION AND PINE STREET RESERVOIR DEMOLITION FOR THE UTILITIES DEPARTMENT OF GRAND ISLAND, NEBRASKA

STRUCTURAL
KIMBALL STREET RESERVOIR
STRUCTURAL SECTIONS AND DETAILS

SHEET 9
DWG 2-S-2
DATE JUNE 2003
PROJ 171243.01.02

REUSE OF DOCUMENTS: THIS DOCUMENT AND THE IDEAS AND DESIGNS INCORPORATED HEREIN AS AN INSTRUMENT OF PROFESSIONAL SERVICE IS THE PROPERTY OF CH2M HILL AND IS NOT TO BE USED, IN WHOLE OR IN PART, FOR ANY OTHER PROJECT WITHOUT THE WRITTEN AUTHORIZATION OF CH2M HILL

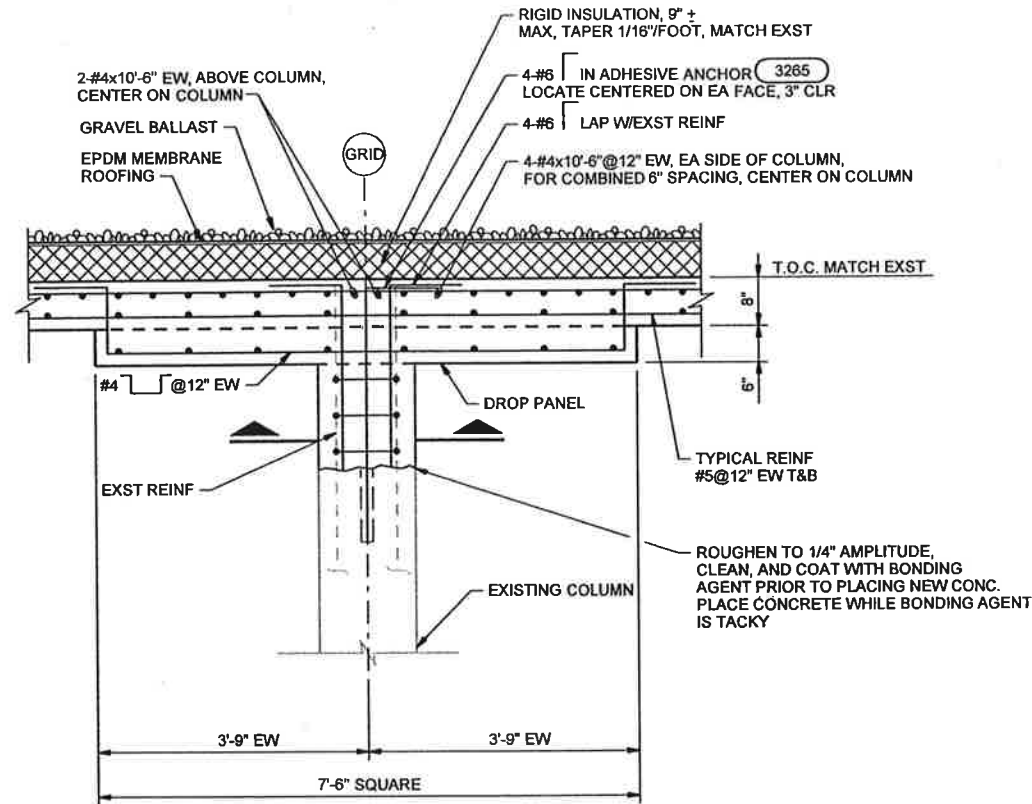

ELEVATION
3/4"=1'-0"

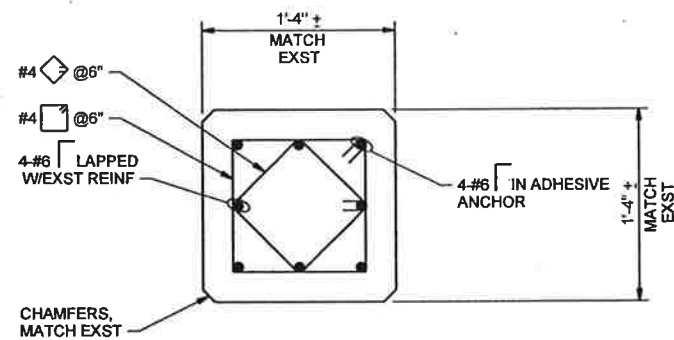

SECTION A
1 1/2"=1'-0"

SECTION A
VARIES 2-S-1

ROUGHEN TO 1/4" AMPLITUDE, CLEAN, AND COAT WITH BONDING AGENT PRIOR TO PLACING NEW CONC. PLACE CONCRETE WHILE BONDING AGENT IS TACKY

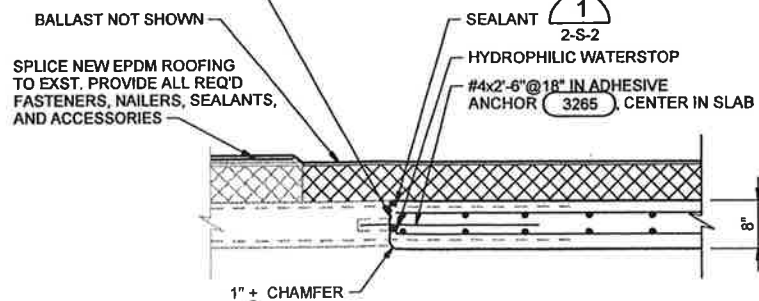

SECTION B
3/4"=1'-0" 2-S-1

MASONRY VENEER NOTES:

1. REPLACE ALL TILE VENEER AFFECTED BY DEMOLITION AND CONSTRUCTION ACTIVITIES. EXERCISE CAUTION DURING DEMOLITION AND SALVAGE AS MUCH EXISTING TILE AS POSSIBLE. DAMAGED TILES SHALL BE REPLACED WITH NEW. NEW TILE SHALL MATCH EXISTING FOR BOTH COLOR AND SIZE.
2. MORTAR COLOR SHALL MATCH EXISTING MORTAR. PROVIDE PIGMENTS AS REQUIRED. MORTAR SHALL CONFORM TO ASTM C270, TYPE S. TOOL JOINTS TO MATCH EXISTING.
3. INSTALL DOVETAIL ANCHOR SLOTS IN NEW CONCRETE WALL AT 2'-0" OC HORIZONTALLY. DOVETAIL ANCHOR SLOTS SHALL BE 20 GAGE, MILL GALVANIZED, DUR-O-WALL D/A 100 DOVETAIL ANCHOR SLOT OR EQUAL.
4. INSTALL DOVETAIL TIES AT 2'-0" OC HORIZONTALLY AND VERTICALLY. PROVIDE ROWS OF TIES AT 2'-0" OC IN THE TOP AND BOTTOM COURSES OF TILE. DOVETAIL TIES SHALL BE 3/16" MINIMUM DIAMETER, HOT-DIP GALVANIZED, DUR-O-WALL D/A 720 DOVETAIL TRIANGULAR TIES OR EQUAL.
5. CLEAN SURFACE OF REPLACED TILE AFTER PLACEMENT. CLEANER SHALL BE COMPATIBLE WITH NEW AND EXISTING TILE. THE USE OF MURATIC ACID IS PROHIBITED

SECTION B
3/4"=1'-0" 2-S-1

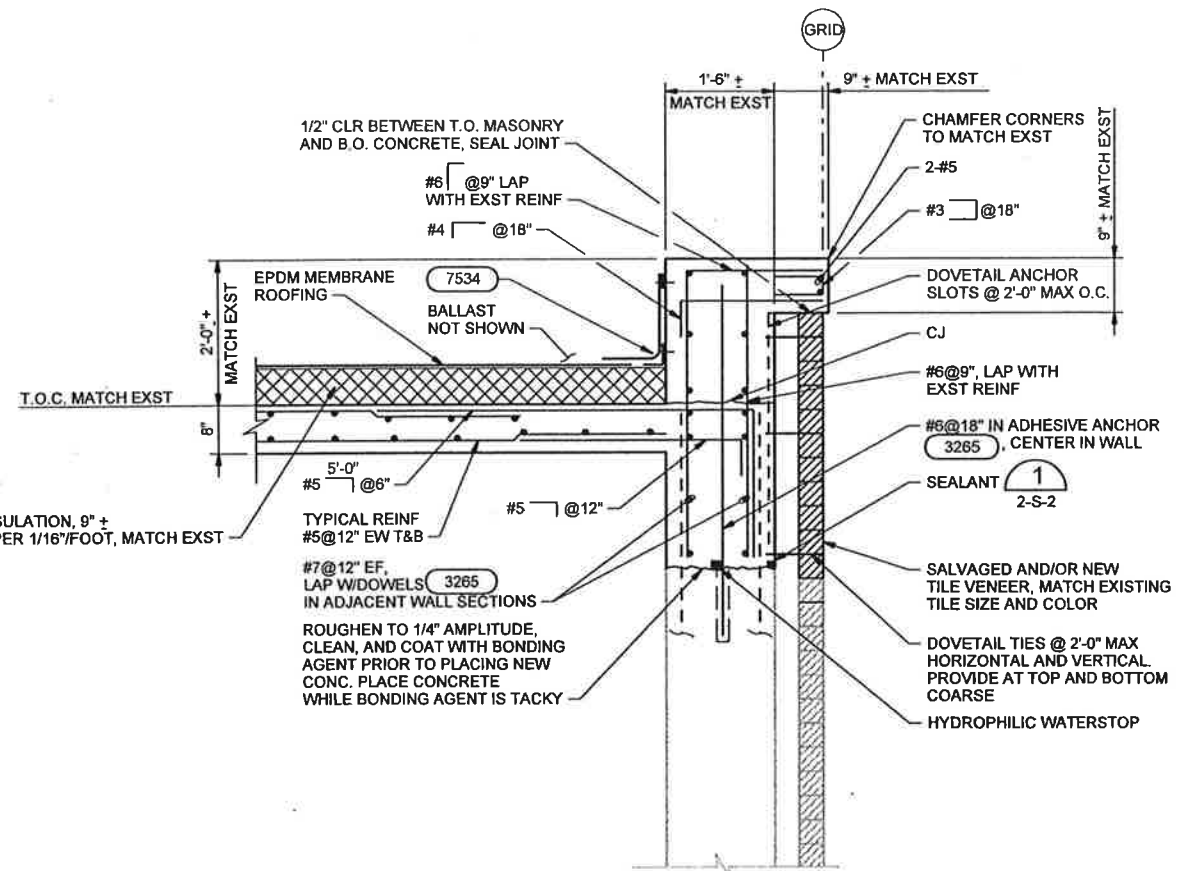

RIGID INSULATION, 9" + MAX, TAPER 1/16"/FOOT, MATCH EXST

SECTION C
3/4"=1'-0" 2-S-1



DSGN	S.PATTERSON					
DR	C.SCHNEE					
CHK	D.SIMON					
APVD	D.SIMON	NO.	DATE	REVISION	BY	APVD

VERIFY SCALE
BAR IS ONE INCH ON ORIGINAL DRAWING.
0 1'
IF NOT ONE INCH ON THIS SHEET, ADJUST SCALES ACCORDINGLY.



KIMBALL STREET RESERVOIR REHABILITATION AND PINE STREET RESERVOIR DEMOLITION FOR THE UTILITIES DEPARTMENT OF GRAND ISLAND, NEBRASKA

STRUCTURAL
KIMBALL STREET RESERVOIR
STRUCTURAL SECTIONS AND DETAILS

SHEET 10
DWG 2-S-3
DATE JUNE 2003
PROJ 171243.01.02

THIS DOCUMENT AND THE IDEAS AND DESIGNS INCORPORATED HEREIN AS AN INSTRUMENT OF PROFESSIONAL SERVICE IS THE PROPERTY OF CH2M HILL AND IS NOT TO BE USED, IN WHOLE OR IN PART, FOR ANY OTHER PROJECT WITHOUT THE WRITTEN AUTHORIZATION OF CH2M HILL

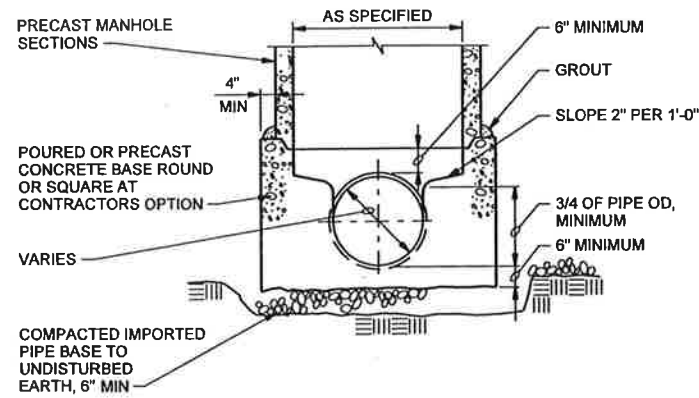

MANHOLE BASE SECTION 24" TO 36" PIPE
NTS

2030A

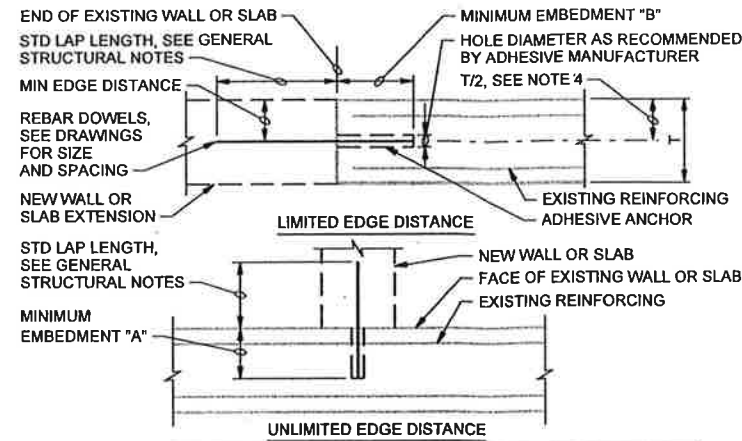

DOWEL SIZE	MINIMUM EDGE DIST	MINIMUM EMBEDMENT A	MINIMUM EMBEDMENT B
#3	2 1/2"	5"	8"
#4	3 1/2"	7"	11"
#5	4"	8"	13"
#6	5"	10 1/2"	18"
#7	6"	12 1/2"	20"
#8	7"	14"	22"
#9	7 1/2"	15"	24"

- NOTES:
- CONFORM TO THE REQUIREMENTS OF SPECIFICATION SECTION 03215, DOWELING FOR CONCRETE.
 - FOLLOW ADHESIVE MANUFACTURER'S INSTRUCTIONS FOR INSTALLATION.
 - USE MINIMUM EMBEDMENTS SHOWN, EXCEPT USE MANUFACTURER'S MINIMUM RECOMMENDED EMBEDMENT IF GREATER.
 - LOCATE DOWELS CENTERED IN WALL OR SLAB UNLESS OTHERWISE NOTED ON DRAWINGS. WHERE 2 ROWS OF DOWELS INDICATED, STAGGER SPACING & LOCATE ALTERNATING DOWELS AT MINIMUM EDGE DISTANCE FROM OPPOSITE FACES.

DRILL-IN DOWELS
NTS

3265

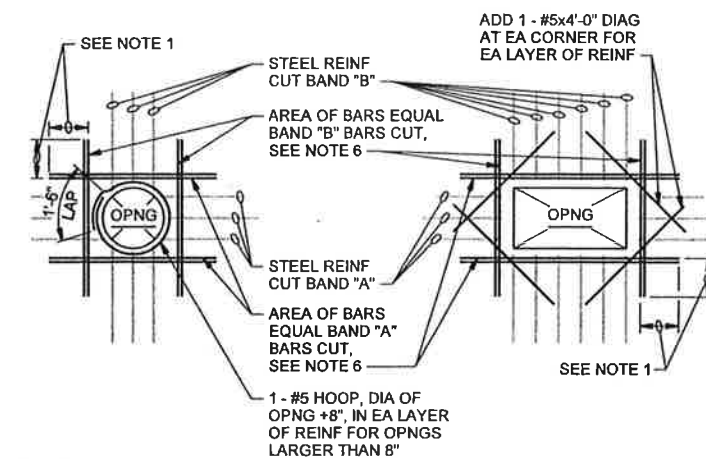

- NOTES:
- PROVIDE MINIMUM LAP, SEE GENERAL STRUCTURAL NOTES.
 - TYPICAL FOR ALL OPENINGS IN CONCRETE WALLS OF BELOW GRADE AND HYDRAULIC STRUCTURES AND ALL STRUCTURAL CONCRETE SLABS UNLESS INDICATED OTHERWISE ON PLANS.
 - DO NOT WELD REINFORCEMENT TO PIPE SLEEVES AND INSERTS.
 - PROVIDE A MINIMUM OF 2 "A" BARS AND 2 "B" BARS EACH SIDE OF OPENING (1 EACH FACE).
 - FOR OPENINGS LARGER THAN 8'-0", REINFORCE SAME AS FOR 8'-0" OPENINGS.
 - SPACE AT 3 BAR DIAMETERS (OR 3" MINIMUM) ON CENTER.

OPENING REINFORCING
NTS

3301

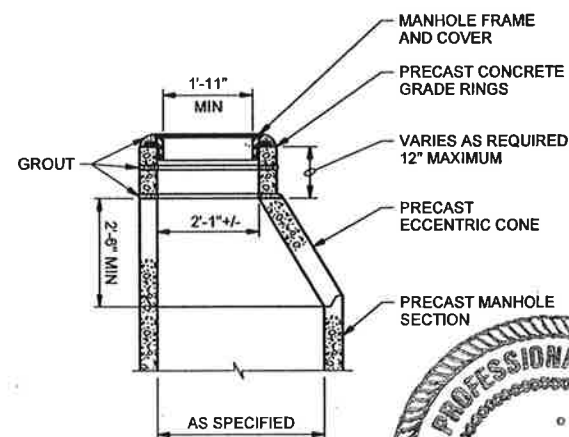

MANHOLE TOP SECTION WITH RING EXTENSION
NTS

2033A

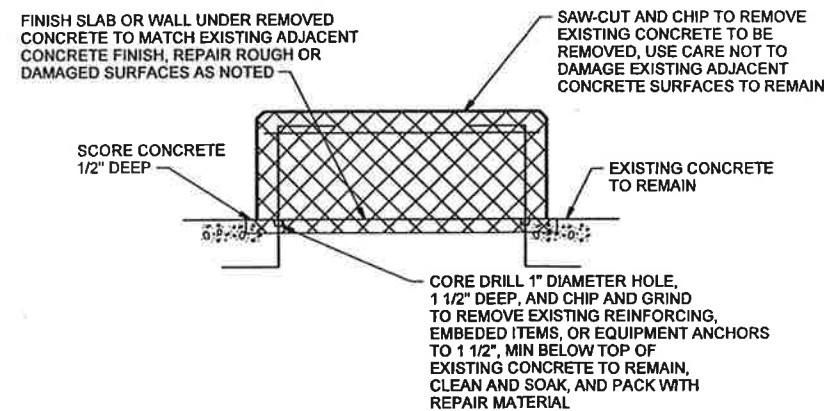

- NOTES:
- REMOVE CONCRETE OUT TO SOUND CONCRETE.
 - WHEN CHIPPING INTO THE SURFACE OF THE EXISTING SLAB OR WALL TO REMAIN, MAKE EDGES PERPENDICULAR TO THE SURFACE. DO NOT FEATHER EDGES.
 - FILL DEFECTIVE AREA WITH AN APPROVED PREPACKAGED REPAIR MATERIAL TO MATCH APPEARANCE OF ADJACENT CONCRETE SURFACES.
 - SOAK SURFACES TO BE PATCHED FOR 24 HOURS PRIOR TO PLACING REPAIR MATERIAL.

CONCRETE DEMOLITION
NTS

3273

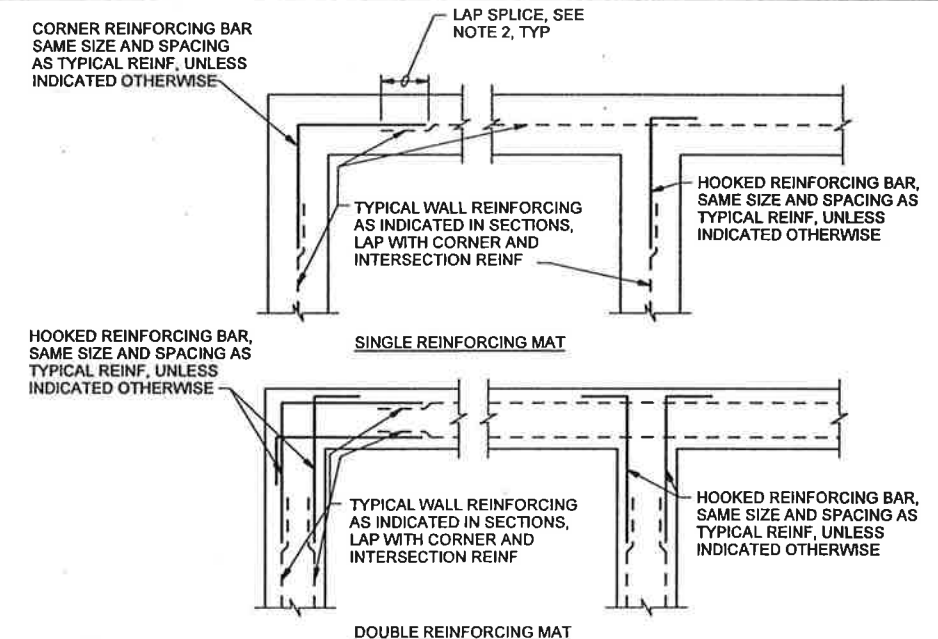

- NOTES:
- WHERE THE CORNER OR INTERSECTION REINFORCING SIZE AND SPACING IS NOT SHOWN, NOTED OR TABULATED ON THE PLANS, THE SIZE AND SPACING SHALL BE THE SAME AS THE WALL HORIZONTAL REINFORCING SHOWN ON THE WALL SECTIONS OR AS NOTED FOR THE REINFORCING BETWEEN THE CORNERS OR INTERSECTIONS.
 - USE THE LAP LENGTH AS REQUIRED FOR THE SMALLER OF THE TWO REINFORCING BARS BEING SPLICED.

TYPICAL WALL CORNER AND INTERSECTION REINFORCING
NTS

3303

DSGN	S.PATTERSON				
DR	C.SCHNEE				
CHK	D.SIMON				
APVD	D.SIMON	NO.	DATE	REVISION	BY
					APVD

VERIFY SCALE
BAR IS ONE INCH ON ORIGINAL DRAWING.
0 1"
IF NOT ONE INCH ON THIS SHEET, ADJUST SCALES ACCORDINGLY.

CH2MHILL

CITY OF GRAND ISLAND

KIMBALL STREET RESERVOIR REHABILITATION AND PINE STREET RESERVOIR DEMOLITION FOR THE UTILITIES DEPARTMENT OF GRAND ISLAND, NEBRASKA

STRUCTURAL
STRUCTURAL STANDARD DETAILS

SHEET 11
DWG SD-1
DATE JUNE 2003
PROJ 171243.01.02

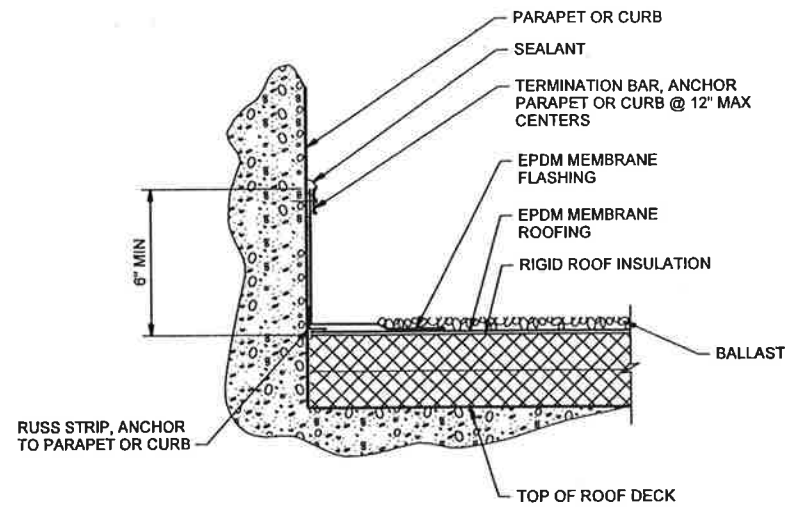

BASE FLASHING

NTS

7534

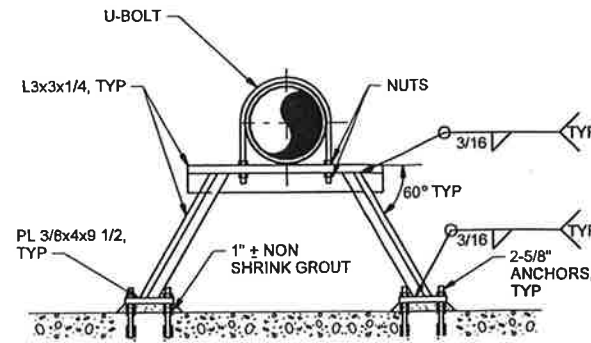

NOTES:

1. ALL MATERIALS, INCLUDING ANCHORS, SHALL BE TYPE 316 SST.
2. ALL WELDS SHALL BE CONTINUOUS.
3. FIELD VERIFY ALL CONTROLLING DIMENSIONS PRIOR TO FABRICATION.

STABILIZING BRACKETS

NTS

15518

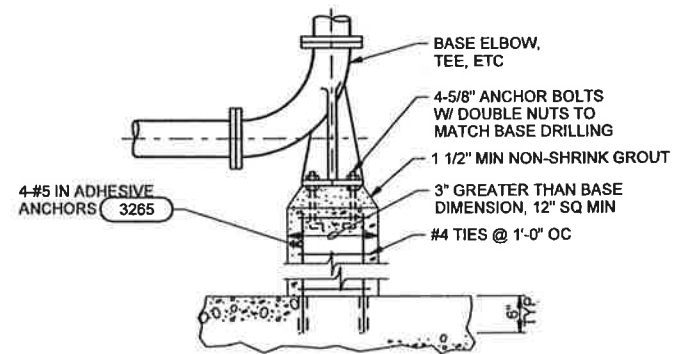

NOTES:

1. ALSO USE FOR SUPPORT OF HORIZONTAL TEE OR CROSS.

VERIFY PIPE SIZES AND ANCHOR BOLT SIZE FOR EACH APPLICATION.

CATALOG STANDARD PRODUCTS ARE AVAILABLE IN LIMITED MATERIALS AND SIZES. SPECIAL MATERIALS AND SIZES REQUIRE FABRICATION TO CONFORM TO SPECIFICATION.

BASE BEND

NTS

15517



DSGN	S.PATTERSON					
DR	C.SCHNEE					
CHK	D.SIMON					
APVD	D.SIMON	NO.	DATE	REVISION	BY	APVD

VERIFY SCALE
 BAR IS ONE INCH ON ORIGINAL DRAWING.
 IF NOT ONE INCH ON THIS SHEET, ADJUST SCALES ACCORDINGLY.



KIMBALL STREET RESERVOIR REHABILITATION AND PINE STREET RESERVOIR DEMOLITION FOR THE UTILITIES DEPARTMENT OF GRAND ISLAND, NEBRASKA

STRUCTURAL
STRUCTURAL STANDARD DETAILS

SHEET 12
DWG SD-2
DATE JUNE 2003
PROJ 171243.01.02

THIS DOCUMENT AND THE IDEAS AND DESIGNS INCORPORATED HEREIN AS AN INSTRUMENT OF PROFESSIONAL SERVICE IS THE PROPERTY OF CH2MHILL. REUSE OF DOCUMENTS: CH2MHILL AND IS NOT TO BE USED, IN WHOLE OR IN PART, FOR ANY OTHER PROJECT WITHOUT THE WRITTEN AUTHORIZATION OF CH2MHILL. © CH2M HILL