

LONGITUDINAL CONTRACTION JOINT
WHEN PAVED IN FULL WIDTH

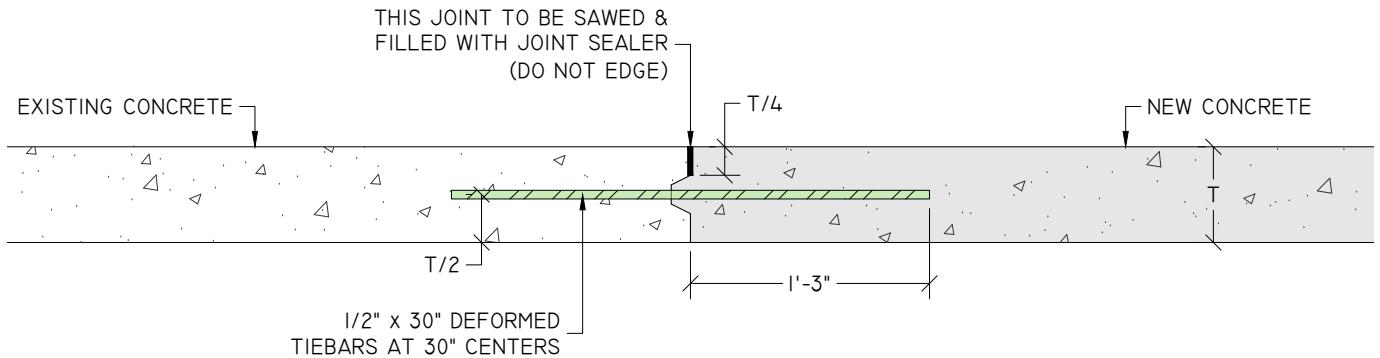

KEYED CONSTRUCTION JOINT

WHEN PAVED IN HALF WIDTH AND/OR
ADJACENT JOINT IS PLACED FURTHER THAN 5'-0"

NOTES:

- I. CONSTRUCTION OF THESE JOINTS & SAWING SHALL BE INCIDENTAL TO PAVING

	<p style="text-align: center;">LONGITUDINAL JOINT DETAILS</p> <p style="text-align: center;">CITY STANDARD PLANS & SPECIFICATIONS GRAND ISLAND, NEBRASKA</p>	PLAN	210
		SHEET	1 OF 1
		DRAWN BY:	LDC DATE: SEP 1970
		REVISED BY:	MLS DATE: JAN 2021
		APPROVED BY:	KJK DATE: APR 2021