



CONTRACT DOCUMENTS & SPECIFICATIONS

for

Curb Ramp Project No. 2024-CR-2 CDBG

Bid Opening

Thursday, January 11, 2024 @ 2:15 pm
City of Grand Island, City Hall
100 East 1st Street
Grand Island, NE 68801

**ENGINEERING DIVISION
DEPARTMENT OF PUBLIC WORKS
GRAND ISLAND, NEBRASKA**

DECEMBER 2023



CURB RAMP PROJECT NO. 2024-CR-2 CDBG

CITY OF GRAND ISLAND, NEBRASKA

TABLE OF CONTENTS

1. Bidder Checklist
2. Advertisement to Bidders
3. Contractor's Bid
4. Instructions to Bidders
5. Insurance Requirements
6. Exempt Sales Certificate
7. Purchasing Agent Appointment
8. Contract Agreement
9. Named Equipment / Subcontractors
10. Division I - General Specifications
11. Division IA - Special Provisions
12. Division II – Portland Cement Concrete
13. Division III – Curb and Gutter, Sidewalks and Driveways
14. Division V – Storm and Sanitary Sewer
15. Community Development Block Grant Supplemental Information
 - a. Davis- Bacon Act
 - b. Area Wage Determination
 - c. Fair Labor Standards
16. 2024-CR-2 CDBG Project Plans
17. City of Grand Island Standard Plans 225-228

**BIDDER CHECKLIST FOR
CURB RAMP PROJECT NO. 2024-CR-2 CDBG
CITY OF GRAND ISLAND, NEBRASKA**

Bids must be received by the City Clerk before 2:15 p.m., (local time) on Thursday, January 11, 2024.

The following items must be completed for your bid to be considered.

- This completed bidder checklist form.
- A signed **original and one copy** of the bidding documents.
- Acknowledgment of Addendum(s), if any.
- Firm unit pricing; or lump sum pricing as applicable. (See bid Form)
- A certified check, cashiers check or bid bond in a separate envelope attached to the **outside of the envelope containing the bid**. Each envelope must be clearly marked indicating its contents. Failure to submit the necessary qualifying information in clearly marked and separate envelopes will result in your bid not being opened.
- Acknowledgement of **PERFORMANCE BOND** requirement on award of the Contract. The successful Contractor shall furnish a Performance Bond which shall be in an amount equal to the full contract price, guaranteeing faithful compliance with all requirements of the contract documents and complete fulfillment of the contract, and payment of all labor, material and other bills incurred in carrying out this contract. According to Nebraska Law, the surety company executing the Performance Bond must be authorized to do business in the State of Nebraska.
- Acknowledgement of **PAYMENT BOND** requirement on award of the contract. The successful contractor shall furnish a Payment Bond which shall be in an amount equal to the full contract price, guaranteeing protection of all persons supplying labor and materials to the contractor or its subcontractors for the performance of the work provided for in the contract. In accordance with Nebraska Law, the surety company executing the Payment Bond must be authorized to do business in the State of Nebraska.

** If checked you will be claiming the individual pricing as listed on the Bid Form is proprietary information and should not be released under a public records request. The total amount of the bid is not considered proprietary information and will be released pursuant to City Procurement Code.*

Bidder Company Name

Date

Print – Name of Person Completing Bid

Signature

ADVERTISEMENT TO BIDDERS
for

CURB RAMP PROJECT NO. 2024-CR-2 CDBG

for
CITY OF GRAND ISLAND, NEBRASKA

Sealed bids will be **received at the office of the City Clerk**, 100 E. First Street., Grand Island, NE 68801 or P.O. Box 1968, Grand Island, Nebraska 68802 until **2:15 p.m., (Local Time), Thursday, January 11, 2024**, for the construction of **Curb Ramp Project No. 2024-CR-2 CDBG** for the City of Grand Island. Bids will be publicly opened at this time in the Conference Room #1 located on 1st floor of City Hall. Bids received after specified time will be returned unopened to sender.

Bids shall be submitted on forms which will be furnished by the City OR bidding documents, plans, and specifications for use in preparing bids may be downloaded from the Quest CDN website, www.QuestCDN.com for a forty-two dollar (\$42) fee. Bids must be uploaded to the Quest CDN website and received before the specified time to be considered. Each bidder shall submit with their bid a certified check, a cashiers check or bid bond payable to the City Treasurer in an amount no less than five percent (5%) of the bid price which shall guarantee good faith on the part of the bidder and the entering into a contract within fifteen (15) days, at the bid price, after acceptance by the City. **“Your certified check, cashiers check or bid bond must be submitted in a separate envelope attached to the outside of the envelope containing the bid.”** Each envelope must be clearly marked indicating its contents. **Failure to submit the necessary qualifying information in clearly marked and separate envelopes will result in your bid not being opened or considered.** OR Bid bonds must be uploaded to Quest CDN, www.QuestCDN.com. Bid bonds must be issued by surety companies authorized to do business in the State of Nebraska. **Please return one original and one copy of each bid sheet.**

The successful bidder will be required to comply with fair labor standards as required by Nebraska R.R.S. 73-102 and comply with Nebraska R.R.S. 48-657 pertaining to contributions to the Unemployment Compensation Fund of the State of Nebraska.

Successful bidder shall comply with the City's insurance requirements, and supply performance and payment bonds. Successful bidder shall maintain a Drug Free Workplace Policy.

Bids will be evaluated by the Purchaser based on price, quality, adherence to schedule, plan and specification, economy and efficiency of operation, experience and reputation of bidder, ability, capacity, and skill of the bidder to perform contract required and adaptability of the particular items to the specific use intended.

The Purchaser reserves the right to reject any or all bids and to waive irregularities therein and to accept whichever bid that may be in the best interest of the City, at its sole discretion.

GRATUITIES AND KICKBACKS: City Code states that it is unethical for any person to offer, give, or agree to give any City employee or former City employee, or for any City employee or former City employee to solicit, demand, accept, or agree to accept from another person, a gratuity or an offer of employment in connection with any decision, approval, disapproval, recommendation, or preparation of any part of a program requirement or a purchase request, influencing the content of any specification or procurement standard, rendering of advice, investigation, auditing, or in any other advisory capacity in any proceeding or application, request for ruling, determination, claim or controversy, or other particular matter, pertaining to any program requirement or a contract or subcontract, or to any solicitation or proposal therefore. It shall be unethical for any payment, gratuity, or offer of employment to be made by or on behalf of a subcontractor under a contract to the prime contractor or higher tier subcontractor or any person associated therewith, as an inducement for the award of a subcontract to order.

No bidder may withdraw their bid for a period of forty-five (45) days after date of opening bids.

TITLE VI: The City of Grand Island, in accordance with Title VI of the Civil Rights Act of 1964, 78 Stat. 252, 42 U.S.C 2000d to 2000d-4 and Title 49, Code of Federal Regulations, Department of Transportation, Subtitle A, Office the Secretary, Part 21, Nondiscrimination in Federally assisted programs of the Department of Transportation issued pursuant to such Act, hereby notified all bidden that it will affirmatively insure that in any contact entered into pursuant to this advertisement, minority business enterprises will be afforded full opportunity to submit bids in response to this invitation and will not be discriminated against on the grounds of race, color, or national origin, sex, age and disability/handicap in consideration for an award.

SECTION 504/ADA NOTICE TO THE PUBLIC: The City of Grand Island does not discriminate on the basis of disability in admission of its programs, services, or activities, in access to them, in treatment of individuals with disabilities, or in any aspect of their operations. The City of Grand Island also does not discriminate on the basis of disability in its hiring or employment practices.

This notice is provided as required by Title II of the Americans with Disabilities Act of 1990 and Section 504 of the Rehabilitation Act of 1973. Questions, complaints, or requests for additional information or accommodation regarding the ADA and Section 504 may be forwarded to the designated ADA and Section 504 compliance coordinator.

City Administrator
308-389-0140
100 East First Street, Grand Island, NE 68801
Monday through Friday; 8:00 a.m. to 5:00 p.m.

Plans and specifications for use in preparing bids may be obtained from the office of the City Engineer, Second Floor, City Hall, 100 East First Street, Grand Island, NE.

RaNae Edwards
City Clerk

CONTRACTOR'S BID

**CURB RAMP PROJECT NO. 2024-CR-2 CDBG
CITY OF GRAND ISLAND, NEBRASKA**

CONTRACTOR'S BID

TO THE MEMBERS OF THE COUNCIL
CITY OF GRAND ISLAND
GRAND ISLAND, NEBRASKA

THE UNDERSIGNED BIDDER, having examined the plans, specifications, general and special conditions, and other proposed contract documents, and all addenda thereto and being acquainted with and fully understanding (a) the extent and character of the work covered by this Bid, (b) the location, arrangement, and specified requirements for the proposed work, (c) the location, character, and condition of existing streets, roads, highways, railroad, pavements, surfacing, walks, driveways, curbs, gutters, trees, sewers, utilities, drainage courses and structures, and other installations, both surface and underground which may affect or be affected by the proposed work, (d) the nature and extent of the excavations to be made and the handling and re-handling of excavated materials, (e) the location and extent of necessary or probable dewatering requirements, (f) the difficulties and hazards to the work which might be caused by storm and flood water, (g) local conditions relative to labor, transportation, hauling and rail delivery facilities, and (h) all other factors and conditions affecting or which may be affected by the work.

HEREBY PROPOSES to furnish all required materials, supplies, equipment, tools and plans, to perform all necessary labor and supervision, and to construct, install, erect, equip and complete all work stipulated in, required by and in accordance with the contract documents and the plans, specifications and other documents referred to therein (as altered, amended or modified by all addenda thereto) for and in consideration of the following prices:

BID SECTION A- WHEELER AVENUE

ITEM #	ITEM DESCRIPTION	QUANTITY	UNIT	UNIT COST	TOTAL COST
1	MOBILIZATION	1.00	LS	\$	\$
2	REMOVE WALK	2,314.00	SF	\$	\$
3	REMOVE PAVEMENT	151.00	SY	\$	\$
4	SAW CUT	700.00	LF	\$	\$
5	BUILD WALK	2,103.00	SF	\$	\$
6	BUILD WALK WITH CURB	497.00	SF	\$	\$
7	BUILD 6" PCC PAVEMENT	151.00	SY	\$	\$
8	BUILD CURB	538.00	LF	\$	\$
9	REMOVE & RESET LANDSCAPE BLOCKS	46.00	LF	\$	\$
10	ADJUST CURB INLET- TYPE B	3.00	EA	\$	\$
11	SOD AREA	215.00	SY	\$	\$
12	DETECTABLE WARNING PANELS	202.00	SF	\$	\$
13	LANDSCAPING AND SPRINKLER REPAIRS	1.00	LS	\$	\$
14	TRAFFIC CONTROL	1.00	LS	\$	\$
BID SECTION "A" TOTAL					\$

BID SECTION B– GRACE ABBOTT PARK

ITEM #	ITEM DESCRIPTION	QUANTITY	UNIT	UNIT COST	TOTAL COST
1	MOBILIZATION	1.00	LS	\$	\$
2	REMOVE WALK	2,585.00	SF	\$	\$
3	REMOVE PAVEMENT	184.00	SY	\$	\$
4	SAW CUT	656.00	LF	\$	\$
5	BUILD WALK	2,749.00	SF	\$	\$
6	BUILD 4" PCC STAMPED WALK	113.00	SF	\$	\$
7	BUILD 6" PCC PAVEMENT	184.00	SY	\$	\$
8	BUILD CURB	541.00	LF	\$	\$
9	REMOVE & REPLACE CHAIN LINK FENCE	20.00	LF	\$	\$
10	ADJUST MANHOLE TO GRADE	1.00	EA	\$	\$
11	REMOVE ABANDONED VALVE BOX	1.00	EA	\$	\$
12	SOD AREA	196.00	SY	\$	\$
13	DETECTABLE WARNING PANELS	228.00	SF	\$	\$
14	LANDSCAPING AND SPRINKLER REPAIRS	1.00	LS	\$	\$
15	TRAFFIC CONTROL	1.00	LS	\$	\$
BID SECTION "B" TOTAL					\$

BID SECTION C– GREENWICH STREET & 12TH STREET

ITEM #	ITEM DESCRIPTION	QUANTITY	UNIT	UNIT COST	TOTAL COST
1	MOBILIZATION	1.00	LS	\$	\$
2	REMOVE WALK	680.00	SF	\$	\$
3	REMOVE PAVEMENT	22.00	SY	\$	\$
4	SAW CUT	122.00	LF	\$	\$
5	BUILD WALK	872.00	SF	\$	\$
6	BUILD 6" PCC PAVEMENT	22.00	SY	\$	\$
7	BUILD CURB	90.00	LF	\$	\$
8	SOD AREA	65.00	SY	\$	\$
9	DETECTABLE WARNING PANELS	64.00	SF	\$	\$
10	LANDSCAPING AND SPRINKLER REPAIRS	1.00	LS	\$	\$
11	TRAFFIC CONTROL	1.00	LS	\$	\$
BID SECTION "C" TOTAL					\$

TOTAL OF BID SECTION A + B + C= \$

The City reserves the right to reject any bid section(s) submitted by the successful bidder. Bid sections will be completed as budgeted funds allow.

EXPERIENCE DATA:

Each bidder shall supply the following data on their experience:

Name of Bidder: _____

Project Owner/Contact/Phone No. Project Location Completion Date

Additional Data: _____

INSURANCE: Bidder acknowledges that bid includes compliance with the attached insurance requirements.

ADDENDA:

Bidder acknowledges that the following Addendums were received and considered in Bid preparation.

<u>ADDENDUM NO.</u>	<u>DATE</u>	<u>SIGNATURE</u>
_____	_____	_____
_____	_____	_____

Exceptions shall be listed in the following blanks. If additional space is required for exception explanation, please reference and attach a letter to bid. Reference shall not be made to other attachments for exceptions and supplementary terms. Failure to outline such exceptions as specifically stated herein will require the successful bidder to comply with these specifications. In case of conflict between the bid and these specifications, these specifications shall govern unless specific exceptions are listed by the bidder.

Exceptions to specifications, pages _____

The undersigned bidder agrees to furnish the required performance and payment bond and to enter into a contract within fifteen (15) days after acceptance of this Bid, and further agrees to complete all work covered by the foregoing bid in accordance with specified requirements. **No work shall commence until the Certificate of Insurance and bonds (when required) are approved by the City and the contract is executed.** The proposed work can commence after the contract is signed and the required bond is approved. All work associated with the contract shall be completed no later than **October 31, 2024.**

Enclosed herewith is the required bid guarantee in the amount of _____ Dollars (\$_____)

which the undersigned bidder agrees is to be forfeited to and become the property of the City of Grand Island, Nebraska, as liquidated damages should this Bid be accepted and a contract be awarded to them and they fail to enter into a contract in the form prescribed and to furnish the required bond within fifteen (15) days, but otherwise the aforesaid bid guarantee will be returned upon signing the contract and delivering the approved bond.

In submitting the bid it is understood that the right is reserved by the City to reject any and all bids; to waive irregularities therein and to accept whichever bid that may be in the best interest of the City. It is understood that this bid may not be withdrawn by the bidder until after forty-five (45) days from bid opening.

In submitting the bid, the bidder states that bidder fully complies with, and will continue to comply with, applicable State fair labor standards as required by section 73-102 RRS, 1943 and also complies with, and will continue to comply with, section 48-657 RRS, 1943 pertaining to contributions to the Unemployment Compensation Fund of the State of Nebraska.

The undersigned bidder hereby certifies (a) that this bid is genuine and is not made in the interest of or in the behalf of any undisclosed person, firm or corporation, and is not submitted in conformity with any agreement or rules of any group, association, organization or corporation, (b) that they have not directly or indirectly induced or solicited any person, firm or corporation to refrain from bidding, (c) that they have not sought, by collusion or otherwise, to obtain for themselves an advantage over any other bidder or over the City of Grand Island, and (d) that they have not directly or indirectly induced or solicited any other bidder to put in a false or sham bid.

DATED _____

SIGNATURE OF BIDDER:

If an Individual: _____ doing business

as _____

If a Partnership: _____

by _____, member of firm.

If a Corporation: _____

by _____ (Seal)
Title

BUSINESS ADDRESS OF BIDDER

TELEPHONE NUMBER OF BIDDER

FAX NUMBER OF BIDDER

EMAIL ADDRESS

INSTRUCTIONS TO BIDDERS

INSTRUCTIONS TO BIDDERS
CURB RAMP PROJECT NO. 2024-CR-2 CDBG
CITY OF GRAND ISLAND, NEBRASKA

EXCEPTIONS TO SPECIFICATIONS: Each bidder shall carefully check all requirements herein set forth and shall offer items which fully comply with these requirements or shall plainly set forth all points, features, conditions, specifications of items that are non-compliant. Bidder must comply with all applicable Federal, State and Local rules and regulations.

SUBMISSION OF BIDS: All bids shall be submitted using the City's bid form. Bids shall **be addressed to the City Clerk** and plainly marked, "**BID FOR CURB RAMP PROJECT NO. 2024-CR-2 CDBG**".

INSURANCE COVERAGE: The Contractor shall purchase and maintain at their expense as a minimum insurance coverage of such types and in such amounts as are specified herein to protect Contractor and the interest of Owner and others from claims which may arise out of or result from Contractor's operations under the Contract Documents, whether such operations be by Contractor or by any subcontractor or anyone directly or indirectly employed by any of them or for whose acts any of them may be legally liable. Failure of Contractor to maintain proper insurance coverage shall not relieve them of any contractual responsibility or obligation.

BASE BID: The bidder is expected to base their bids on materials and items complying fully with these specifications, and in the event the contractor names in the bid materials items which do not conform, they will be responsible for furnishing materials and items which fully conform at no change in the bid price.

BIDDER QUALIFICATION: Bids will be received only from qualified bidders. A bidder will be considered qualified if they are a recognized manufacturer or supplier of materials and items similar to that specified herein with complete factory facilities in the United States and has had experience in the design and manufacture of items of equal or greater size than that specified herein. If requested, the Bidder shall supply experience data. Such data will be used to assist in determining the qualifications of the Bidder. Bidder must comply with all applicable Federal, State and Local rules and regulations.

GRATUITIES AND KICKBACKS: City Code states that it is unethical for any person to offer, give, or agree to give any City employee or former City employee, or for any City employee or former City employee to solicit, demand, accept, or agree to accept from another person, a gratuity or an offer of employment in connection with any decision, approval, disapproval, recommendation, or preparation of any part of a program requirement or a purchase request, influencing the content of any specification or procurement standard, rendering of advice, investigation, auditing, or in any other advisory capacity in any proceeding or application, request for ruling, determination, claim or controversy, or other particular matter, pertaining to any program requirement or a contract or subcontract, or to any solicitation or proposal therefore. It shall be unethical for any payment, gratuity, or offer of employment to be made by or on behalf of a subcontractor under a contract to the prime contractor or higher tier subcontractor or any person associated therewith, as an inducement for the award of a subcontract to order.

CHECKS OR BID BONDS: Checks or bid bonds of the unsuccessful bidders will be returned when their bids have been rejected and not to exceed forty-five (45) days from the date bids are opened. All bids shall remain in force for this forty-five (45) day Period. The check or bid bond of the successful bidder will be returned when the Contracts are signed by both parties and necessary bonds supplied. Should the Purchaser make an award to a Contractor who refuses to enter into a

Contract and furnish the required bonds within fifteen (15) days after notification of acceptance, then the bid security which has been deposited with the Purchaser will be forfeited to the Purchaser as liquidated damages.

PERFORMANCE BOND: When required, on award of the Contract, the successful Contractor shall furnish a Performance Bond which shall be in an amount equal to the full Contract price, guaranteeing faithful compliance with all requirements of the Contract Documents and complete fulfillment of the Contract, and payment of all labor, material and other bills incurred in carrying out this Contract. According to Nebraska Law, the surety company executing the Performance Bond must be authorized to do business in the State of Nebraska.

PAYMENT BOND: When required, on award of the Contract, the successful Contractor shall furnish a Payment Bond which shall be in an amount equal to the full Contract price, guaranteeing protection of all persons supplying labor and materials to the Contractor or its subcontractors for the performance of the work provided for in the Contract. In accordance with Nebraska Law, the surety company executing the Payment Bond must be authorized to do business in the State of Nebraska.

TAXES: The City of Grand Island is exempt from paying local City and State Sales Tax for materials incorporated into the work. Refer to Exempt Sale Certificate enclosed for your information. Contractor must pay any other tax which might be applicable.

REQUESTS FOR PAYMENT: The City of Grand Island will make payments only after approval at regularly scheduled City Council meetings. These meetings typically occur the second and fourth Tuesday each month. Requests for payment must be received no less than ten (10) working days prior to the designated meeting to allow proper review and consideration. Progress Payments will be permitted during the project, so long as work is being done to the City's satisfaction unless otherwise stated in bidding documents.

REQUEST FOR INTERPRETATION: If any person, contemplating submitting a bid for this Contract is in doubt as to the true meaning of any part of the specifications or other proposed Contract documents, they may submit to the Purchasing Department a written request for an interpretation thereof. The person submitting the request will be responsible for its prompt delivery. Any interpretation of the proposed documents will be made by addendum only issued and/or delivered to each person receiving a set of such documents. The addenda upon closing shall become a part of the Contract. The Purchasing Department will not be responsible for any other explanation or interpretation of the proposed documents.

TIME OF COMPLETION: All work associated with the contract shall be completed no later than **October 31, 2024**.

CLEANING UP: Contractor shall maintain a clean and safe work area while on site.

ADDENDA: Any addendum to the specifications issued during the time allowed for preparation of bids shall be covered in the bid and shall become a part of the specifications. Addendums issued before the date of the letting will be sent to all bidders. One signed copy is to be returned immediately to the Purchasing Department (or other department if so designated in the Addendum) as acknowledgment of receipt.

MODIFICATION OF BIDS: Bids may be modified or withdrawn by an appropriate document duly executed in the manner that a bid must be executed and delivered to the place where bids are to be submitted at any time prior to the final time set for receiving bids. Bidders may modify or withdraw bids by Fax communication at any time prior to the time set for receiving bids provided this instruction

is positively identified. Any Fax modification should not reveal the amended bid price but should provide only the addition, subtraction or other modifications. A duly-executed document confirming the Fax modification shall be submitted within three days after bids are opened.

BID DATA: Bidders shall submit bid data, if required, on items offered in the Bid by **furnishing one original and one copy of the completed Contractor's Bid form**. The bid sheets shall be filled out legibly in ink to permit reproduction.

BIDDER SECURITY: Bidder security, when required, shall be enclosed in a separate envelope marked, "**BIDDER SECURITY/BID FOR CURB RAMP PROJECT NO. 2024-CR-2 CDBG**". The envelope shall contain only a cashier's check, certified check or bidder's bond payable to the City of Grand Island Treasurer in an amount no less than five (5) percent of the bid price which shall guarantee good faith on the part of the bidder and the entering into a contract within fifteen (15) days, at the bid price, after acceptance by the City. **Failure to submit the necessary qualifying information in clearly marked and separate envelopes will result in your bid not being opened or considered.** OR Bid bonds must be uploaded to Quest CDN, www.QuestCDN.com. Bid bonds must be issued by surety companies authorized to do business in the State of Nebraska.

This separate envelope shall be attached to a sealed envelope containing the bid and any other bid materials. This second envelope shall be labeled "BID FOR CURB RAMP PROJECT NO. 2024-CR-2 CDBG" and be addressed to the City Clerk. Bids of an incomplete nature or subject to multiple interpretation may, at the option of the Purchaser, be rejected as being irregular.

FINANCIAL STATEMENT: The bidder shall furnish, upon request, a complete financial statement signed by the bidder, if an individual, by all partners if the bidder is a partnership and, by the President or Secretary, if the bidder is a corporation.

DRUG FREE WORKPLACE POLICY: Bidders shall furnish, upon request, a copy of their Drug Free workplace Policy.

EQUAL EMPLOYMENT OPPORTUNITY: The Contractor agrees that during the performance of this Contract not to discriminate in hiring or any other employment practice on the basis of race, color, religion, sex, disability, age or national origin, and to comply with Executive Order 11,246 of September 24, 1965, and the rules, regulations and relevant orders of the Secretary of Labor, and Chapter 20 of the Reissue Revised Statutes of the State of Nebraska.

LOCAL CONDITIONS: Each bidder shall have an authorized representative visit the site of the work and thoroughly inform them of all conditions and factors which would affect the work and the cost thereof, including the arrangement and conditions of existing or proposed structures affecting or affected by the proposed work; the procedure necessary for maintenance of uninterrupted operation; the availability and cost of labor and facilities for transportation, handling, and storage of materials and equipment.

TILE VI: The City of Grand Island, in accordance with Title VI of the Civil Rights Act of 1964, 78 Stat. 252, 42 U.S.C 2000d to 2000d-4 and Title 49, Code of Federal Regulations, Department of Transportation, Subtitle A, Office the Secretary, Part 21, Nondiscrimination in Federally assisted programs of the Department of Transportation issued pursuant to such Act, hereby notified all bidden that it will affirmatively insure that in any contract entered into pursuant to this advertisement, minority business enterprises will be afforded full opportunity to submit bids in response to this invitation and will not be discriminated against on the grounds of race, color, or national origin, sex, age and disability/handicap in consideration for an award.

SECTION 504/ADA NOTICE TO THE PUBLIC: The City of Grand Island does not discriminate on the basis of disability in admission of its programs, services, or activities, in access to them, in treatment of individuals with disabilities, or in any aspect of their operations. The City of Grand Island also does not discriminate on the basis of disability in its hiring or employment practices. This notice is provided as required by Title II of the Americans with Disabilities Act of 1990 and Section 504 of the Rehabilitation Act of 1973. Questions, complaints, or requests for additional information or accommodation regarding the ADA and Section 504 may be forwarded to the designated ADA and Section 504 compliance coordinator.

City Administrator
308-389-0140
100 East First Street, Grand Island, NE 68801
Monday through Friday; 8:00 a.m. to 5:00 p.m.

It must be understood and agreed that all such factors have been investigated and considered in the preparation of every bid submitted. No claims for financial adjustment to any Contract awarded for the work under these Specifications and documents will be permitted by the City, which are based on lack of such prior information, or its effect on the cost of the work.

CORRESPONDENCE: Correspondence regarding drawings, instruction manuals, and other engineering data shall be clearly marked "FOR ENGINEERING DEPARTMENT" and sent through:

City of Grand Island
Public Works Department/Engineering Division
P.O. Box 1968
Grand Island, NE 68802-1968
(308) 385-5455
Attn: Tim Golka

LOCAL BIDDER PREFERENCE: In case of tied low bids, all other things being equal, preference shall be given in the following order:

1. To those bidders who manufacture their products within the limits of the City of Grand Island.
2. To those bidders who manufacture their products within the limits of the County of Hall.
3. To those bidders who package, process, or through some other substantial operation have employees and facilities for these purposes in the City of Grand Island.
4. To those bidders who package, process, or through some other substantial operation have employees and facilities for these purposes in the County of Hall.
5. To those bidders who maintain a bona fide business office in the City of Grand Island, whose products may be made outside the confines of the City of Grand Island.
6. To those bidders who maintain a bona fide business office in the County of Hall, whose products may be made outside the confines of the County of Hall.
7. To those bidders whose commodities are manufactured, mined, produced, or grown within the State of Nebraska, and to all firms, corporations, or individuals doing business as Nebraska firms, corporations or individuals, when quality is equal or better, and delivered price is the same or less than the other bids received.
8. To those bidders whose commodities are manufactured, mined, produced, or grown within the United States of America, and to all firms, corporations, or individuals doing business as firms registered in states other than Nebraska, when quality is equal or better, and delivered price is the same or less than the other bids received.

INSURANCE REQUIREMENTS

MINIMUM INSURANCE REQUIREMENTS

CURB RAMP PROJECT NO. 2024-CR-2 CDBG

CITY OF GRAND ISLAND, NEBRASKA

You are urged to include in your bid compliance with the City's minimum insurance requirements; however, any non-compliance must be detailed in the Exceptions Section of the bid. Compliance with the specified OCP coverage is mandatory.

The successful bidder shall obtain insurance from companies authorized to do business in Nebraska of such types and in such amounts as may be necessary to protect the bidder and the interests of the City against hazards or risks of loss as hereinafter specified. This insurance shall cover all aspects of the Bidder's operations and completed operations. Failure to maintain adequate coverage shall not relieve bidder of any contractual responsibility or obligation. Minimum insurance coverage shall be the amounts stated herein or the amounts required by applicable law, whichever are greater.

1. WORKERS COMPENSATION AND EMPLOYER'S LIABILITY

This insurance shall protect the Bidder against all claims under applicable State workers compensation laws. This insurance shall provide coverage in every state in which work for this project might be conducted. The liability limits shall not be less than the following:

Workers Compensation	Statutory Limits
Employers Liability	\$100,000 each accident
	\$100,000 each employee
	\$500,000 policy limit

2. BUSINESS AUTOMOBILE LIABILITY

This insurance shall be written in comprehensive form and shall protect the Bidder, Bidder's employees, or subcontractors from claims due to the ownership, maintenance, or use of a motor vehicle. The liability limits shall be not less than the following:

Bodily Injury & Property Damage	\$ 500,000 Combined Single Limit
---------------------------------	----------------------------------

3. COMPREHENSIVE GENERAL LIABILITY

The comprehensive general liability coverage shall contain no exclusion relative to explosion, collapse, or underground property. The liability limits shall be not less than the following:

Bodily Injury & Property Damage	\$ 500,000 each occurrence
	\$1,000,000 aggregate

4. UMBRELLA LIABILITY INSURANCE

This insurance shall protect the Bidder against claims in excess of the limits provided under employer's liability, comprehensive automobile liability, and commercial general liability policies. The umbrella policy shall follow the form of the primary insurance, including the application of the primary limits. The liability limits shall not be less than the following:

Bodily Injury & Property Damage	\$1,000,000 each occurrence
	\$1,000,000 general aggregate

5. ADDITIONAL REQUIREMENTS

The City may require insurance covering a Bidder or subcontractor more or less than the standard requirements set forth herein depending upon the character and extent of the work to be performed by such Bidder or subcontractor.

Insurance as herein required shall be maintained in force until the City releases the Bidder of all obligations under the Contract.

The Bidder shall provide and carry any additional insurance as may be required by special provisions of these specifications.

6. CERTIFICATE OF INSURANCE

Satisfactory certificates of insurance shall be filed with the City prior to starting any work on this Contract. **The certificates shall show the City as an additional insured on all coverage except Workers Compensation. The certificate shall state that thirty (30) days written notice shall be given to the City before any policy is cancelled (strike the "endeavor to" wording often shown on certificate forms). If the bidder cannot have the "endeavor to" language stricken, the bidder may elect to provide a new certificate of insurance every 30 days during the contract. Bidder shall immediately notify the City if there is any reduction of coverage because of revised limits or claims paid which affect the aggregate of any policy.**

EXEMPT SALE CERTIFICATE

TAX FORM 13

Nebraska Resale or Exempt Sale Certificate for Sales Tax Exemption

Name and Mailing Address of Purchaser			Name and Mailing Address of Seller		
Name			Name		
Legal Name					
Street or Other Mailing Address			Street or Other Mailing Address		
City	State	Zip Code	City	State	Zip Code

Check Type of Certificate

- Single Purchase If single purchase is checked, enter the related invoice or purchase order number _____.
- Blanket If blanket is checked, this certificate is valid until revoked in writing by the purchaser.

I hereby certify that the purchase, lease, or rental by the above purchaser is exempt from the Nebraska sales tax for the following reason:

- Check One** Purchase for Resale (Complete Section A.) Exempt Purchase (Complete Section B.) Contractor (Complete Section C.)

Section A—Nebraska Resale Certificate

Description of Property or Service Purchased

I hereby certify that the purchase, lease, or rental of _____ from the seller listed above is exempt from the Nebraska sales tax as a purchase for resale, rental, or lease in the normal course of our business. The property or service will be resold either in the form or condition in which it was purchased, or as an ingredient or component part of other property or service to be resold.

I further certify that we are engaged in business as a: Wholesaler Retailer Manufacturer Lessor

Description of Product Sold, Leased, or Rented

of _____

My Nebraska Sales Tax ID Number is 01- _____.

If none, state the reason _____,

or Foreign State Sales Tax Number _____ State _____.

Section B—Nebraska Exempt Sale Certificate

The basis for this exemption is exemption category _____ (See the list of Exemption Categories and corresponding numbers on reverse side).

If exemption category 2 or 5 is claimed, enter the following information:

Description of Property or Service Purchased	Intended Use of Property or Service Purchased
_____	_____

If exemption category 3 or 4 is claimed, enter your Nebraska Certificate of Exemption State ID number. 05- _____
Do not enter your Federal Employer ID Number.

If exemption category 6 is claimed, the seller must enter the following information and sign this form below:

Description of Items Sold	Date of Seller's Original Purchase	Was tax paid when purchased by seller? <input type="checkbox"/> Yes <input type="checkbox"/> No	Was item depreciable? <input type="checkbox"/> Yes <input type="checkbox"/> No
---------------------------	------------------------------------	--	---

Section C—For Contractors Only

1. Purchase of building materials or fixtures.

As an Option 1 or Option 3 contractor, I hereby certify that the purchase of building materials and fixtures from the seller listed above are exempt from Nebraska sales tax. My Nebraska Sales or Use Tax ID Number is: _____.

2. Purchases made by an Option 2 contractor under a Purchasing Agent Appointment on behalf of _____
(exempt entity)

As an Option 2 contractor, I hereby certify that the purchase of building materials and fixtures from the seller listed above is exempt from Nebraska sales tax pursuant to the **attached** Purchasing Agent Appointment and Delegation of Authority for Sales and Use Tax, Form 17.

Any purchaser, agent, or other person who completes this certificate for any purchase which is not for resale, lease, or rental in the regular course of the purchaser's business, or is not otherwise exempted from sales and use taxes is subject to a penalty of \$100 or ten times the tax, whichever amount is larger, for each instance of presentation and misuse. With regard to a blanket certificate, this penalty applies to each purchase made during the period the blanket certificate is in effect. Under penalties of law, I declare that I am authorized to sign this certificate, and to the best of my knowledge and belief, it is correct and complete.

**sign
here** ▶

Authorized Signature _____

Title _____

Date _____

Authorized Signature Name (please print) _____

**Do not send this certificate to the Nebraska Department of Revenue. Keep it as part of your records.
Sellers cannot accept incomplete certificates.**

**The Department is committed to the fair administration of the Nebraska tax laws. It is unlawful to claim an exemption for purchases of property or services that are subject to tax. Sellers are encouraged to notify the Department of any unlawful use of this form.
revenue.nebraska.gov, 800-742-7474 (NE and IA), 402-471-5729**

Instructions

Who May Issue a Resale Certificate. Purchasers are to give the seller a properly completed Form 13, Section A, when making purchases of property or taxable services that will subsequently be resold in the purchaser's normal course of business. The property or services must be resold in the same form or condition as when purchased, or as an ingredient or component part of other property that will be resold.

Who May Issue an Exempt Sale Certificate. Form 13, Section B, may be completed and issued by governmental units or organizations that are exempt from paying Nebraska sales and use taxes. See this list in the [Nebraska Sales Tax Exemptions Chart](#). Most nonprofit organizations are **not** exempt from paying sales and use tax. Enter the appropriate number from "Exemption Categories" (listed below) that properly reflects the basis for your exemption.

For additional information about proper issuance and use of this certificate, please review [Reg-1-013, Sale for Resale – Resale Certificate](#), and [Reg-1-014, Exempt Sale Certificate](#).

Contractors. Contractors complete Form 13, Section C, part 1 or part 2 based on the option elected on the [Contractor Registration Database](#).

To make tax-exempt purchases of building materials and fixtures, Option 1 or Option 3 contractors must complete Form 13, Section C, Part 1. To make tax-exempt purchases of building materials and fixtures pursuant to a construction project for an exempt governmental unit or an exempt nonprofit organization, Option 2 contractors must complete Form 13, Section C, Part 2. The contractor must also attach a copy of a properly completed [Purchasing Agent Appointment and Delegation of Authority for Sales and Use Tax, Form 17](#), to the Form 13, and both documents must be given to the supplier when purchasing building materials. See the [contractor information guides](#) and [Reg-1-017, Contractors](#), for additional information. Also, see the Important Note under "Exemption Categories" number 3.

When and Where to Issue. The Form 13 must be given to the seller at the time of the purchase to document why sales tax does not apply to the purchase. The Form 13 must be kept with the seller's records for audit purposes.

Sales Tax Number. A purchaser who is engaged in business as a wholesaler or manufacturer is not required to provide an ID number when completing Section A. Out-of-state purchasers may provide their home state sales tax number. Section B does not require a Nebraska ID number when exemption category 1, 2, or 5 is indicated.

Fully Completed Resale or Exempt Sale Certificate. A fully completed resale or exempt sale certificate is proof for the retailer that the sale was for resale or is exempt. For a resale certificate to be fully completed, it must include: (1) identification of the purchaser and seller, type of business engaged in by the purchaser; (2) sales tax permit number; (3) signature of an authorized person; and (4) the date of issuance.

For an exempt sale certificate to be fully completed, it must include: (1) identification of purchaser and seller; (2) a statement that the certificate is for a single purchase or is a blanket certificate covering future sales; (3) a statement of the basis for exemption, including the type of activity engaged in by the purchaser; (4) signature of an authorized person; and (5) the date of issuance.

Penalties. Any purchaser who gives a Form 13 to a seller for any purchase which is other than for resale, lease, or rental in the **normal** course of the purchaser's business, or is not otherwise exempted from sales and use tax under the Nebraska Revenue Act, is subject to a penalty of \$100 or ten times the tax, whichever is greater, for each instance of presentation and misuse. In addition, any purchaser, or their agent, who fraudulently signs a Form 13 may be found guilty of a Class IV misdemeanor.

Exemption Categories

(Insert appropriate number from the list below in Section B)

1. Governmental units, identified in [Reg-1-072, United States Government and Federal Corporations](#); and [Reg-1-093, Governmental Units](#). Governmental units are not assigned exemption numbers.

Sales to the U.S. government, its agencies, instrumentalities, and corporations wholly owned by the U.S. government are exempt from sales tax. However, sales to institutions chartered or created under federal authority, but which are not directly operated and controlled by the U.S. government for the benefit of the public, generally are taxable.

Purchases by governmental units that are **not** exempt from Nebraska sales and use taxes include, but are not limited to: governmental units of other states; sanitary and improvement districts; rural water districts; railroad transportation safety districts; and county historical societies.

2. Purchases when the intended use renders it exempt. See [Nebraska Sales Tax Exemption Chart](#).
3. Purchases made by organizations that have been issued a [Nebraska Exempt Organization Certificate of Exemption](#) (Certificate of Exemption), [Reg-1-090, Nonprofit Organizations](#); [Reg-1-091, Religious Organizations](#); and [Reg-1-092, Educational Institutions](#), identify these organizations. These organizations are issued a Certificate of Exemption with a state ID number which must be entered in Section B of Form 13.

Important Note: Nonprofit educational institutions must be accredited regionally or nationally and have their primary campus in Nebraska to be exempt from sales and use tax. Also nonprofit organizations providing any of the types of health care or services that qualify to be exempt must be licensed or certified by the Nebraska Department of Health and Human Services (DHHS) to be exempt from sales and use taxes. There is no sales and use tax exemption prior to these entities being accredited, licensed, or certified. They CANNOT issue either a [Resale or Exempt Sale Certificate, Form 13](#), or a [Purchasing Agent Appointment, Form 17](#), to any retailer or contractor relating to purchases of building materials for construction or repair projects performed prior to being accredited, licensed, or certified. After an entity becomes accredited, licensed, or certified upon completion of the construction project, it may submit a [Form 4](#).

Nonprofit **health care organizations** that hold a Certificate of Exemption are exempt for purchases for use at their facility, or portion of the facility, covered by the license issued under the Nebraska Health Care Facility Licensure Act. Only specific types of health care facilities and activities are exempt. Purchases of items for use at facilities that are not covered under the license, or for any other activities that are not specifically exempt, are taxable. The exemption is not for the entire organization that offers different levels of health care or other activities, but is limited to the specific type of health care that is exempt. Purchases for non-exempt types of health care are taxable.

4. Purchases of motor vehicles, trailers, semitrailers watercraft, and aircraft used predominately as common or contract carrier vehicles; accessories that physically become part of the common or contract carrier vehicle; and repair and replacement parts for these vehicles. The exemption ID number must be entered in Section B of the Form 13. An individual or business that has been issued a common or contract carrier certificate of exemption may only use it to purchase those items described above prior to the expiration date on the certificate. The certificate of exemption expires every 5 years. (See [Nebraska Common or Contract Carrier Information Guide](#)).
5. Purchases of manufacturing machinery and equipment made by a person engaged in the business of manufacturing, including repair and replacement parts or accessories, for use in manufacturing. (See [Reg-1-107, Manufacturing Machinery and Equipment Exemption](#)).
6. Occasional sales of used business or farm machinery or equipment productively used by the seller as a depreciable capital asset for more than one year in his or her business. The seller must have previously paid tax on the item being sold. The seller must complete, sign, and give the Exempt Sale Certificate to the purchaser. (See [Reg-1-022, Occasional Sales](#)). The Form 13 must be kept with the purchaser's records for audit purposes.

**PURCHASING AGENT
APPOINTMENT**

TAX FORM 17

Purchasing Agent Appointment and Delegation of Authority for Sales and Use Tax

Section A – Purchasing Agent Appointment

Name and Address of Contractor			Name and Address of Exempt Governmental Unit or Exempt Organization		
Name			Name		
Street or Other Mailing Address			Street or Other Mailing Address		
City	State	Zip Code	City	State	Zip Code
Name and Location of Project			Appointment Information		
Name			Effective Date (See instructions)		
Street Address			Expiration Date		
City	State	Zip Code	Nebraska Exemption Number (Exempt Organizations Only)		

Provide the contract name, number, and a description of the project.

The undersigned governmental unit or exempt organization appoints the above-named contractor and the contractor's delegated subcontractors as its agent to purchase and pay for building materials that will be annexed to real estate by them into the tax exempt construction project identified above.

**sign
here** ▶

Authorized Signature of Exempt Governmental Unit or Exempt Organization

Title

Date

Section B — Delegation of Contractor's Authority A contractor can delegate its authority to its subcontractor.

Name and Address of Subcontractor			Delegation Information for the Project Identified in Section A		
Name			Effective Date		
Street or Other Mailing Address			Expiration Date		
City	State	Zip Code	Portion of Project		

The undersigned contractor hereby delegates authority to the above-named subcontractor to act as the purchasing agent of the named governmental unit or exempt nonprofit organization.

**sign
here** ▶

Signature of Contractor or Authorized Representative

Title

Date

Name and Address of Subcontractor			Delegation Information for the Project Identified in Section A		
Name			Effective Date		
Street or Other Mailing Address			Expiration Date		
City	State	Zip Code	Portion of Project		

The undersigned contractor hereby delegates authority to the above-named subcontractor to act as the purchasing agent of the named governmental unit or exempt nonprofit organization.

**sign
here** ▶

Signature of Subcontractor or Authorized Representative

Title

Date

Name and Address of Subcontractor			Delegation Information for the Project Identified in Section A		
Name			Effective Date		
Street or Other Mailing Address			Expiration Date		
City	State	Zip Code	Portion of Project		

The undersigned contractor hereby delegates authority to the above-named subcontractor to act as the purchasing agent of the named governmental unit or exempt nonprofit organization.

**sign
here** ▶

Signature of Subcontractor or Authorized Representative

Title

Date

Instructions

Section A

Who Can Issue. Any governmental unit or nonprofit organization that is exempt from sales and use tax may appoint a contractor as its purchasing agent for building materials and fixtures that will be annexed to property that belongs to or will belong to the exempt governmental unit or exempt nonprofit organization pursuant to a construction contract or covered under an on-call, repair, or maintenance service agreement. Exempt governmental units and exempt nonprofit organizations are identified in [Sales and Use Tax Regulations 1-072, 1-090, 1-091, 1-092, and 1-093](#).

Important Note: A nonprofit organization that has not received its sales and use tax Exempt Organization Certificate of Exemption, cannot issue either a Purchasing Agent Appointment and Delegation of Authority for Sales and Use Tax, Form 17, or a [Nebraska Resale or Exempt Sale Certificate for Sales Tax Exemption, Form 13](#).

Appointment Information. To appoint a contractor as its purchasing agent, the exempt governmental unit or exempt nonprofit organization must complete Section A. The phrase “upon completion” or similar phrase is not an acceptable expiration date. If the project is not completed before the expiration date, a new purchasing agent appointment must be issued with the new effective and expiration dates. The purchasing agent authority for the contractor becomes effective on the later of the “effective date” or the signature date of the individual authorized to sign the Form 17 on behalf of the exempt governmental unit or exempt nonprofit organization.

When To Issue. The qualified exempt nonprofit organization or exempt governmental unit should issue the completed and signed Form 17 to the contractor BEFORE the contractor annexes any building materials. If the Form 17 is not timely issued, the Option 2 or Option 3 general contractor must pay the sales and use taxes on all building materials annexed to real estate before the effective date or signature date on the appointment.

Important Note: A copy of the completed Form 17 should be retained by the exempt governmental unit or exempt nonprofit organization. The original is to be retained by the contractor.

On-Call, Repair, or Maintenance Agreements. Exempt governmental units and exempt nonprofit organizations, in lieu of issuing a separate purchasing agent appointment to the same Option 2 or Option 3 contractor for each service call, may issue to the Option 2 or Option 3 contractor a written on-call, repair, or maintenance agreement and purchasing agent appointment that covers a calendar year or part of a calendar year. A new written agreement and purchasing agent appointment must be issued at least each calendar year.

Section B

Delegation of Contractor’s Authority. The contractor or subcontractor who has previously been delegated to be a purchasing agent for a portion of the project may delegate his or her authority as the purchasing agent to other subcontractors for all or a portion of the project. Contractors who are delegating their authority as the purchasing agent are only required to complete Section B. Contractors and subcontractors must issue a separate Form 17 to each subcontractor to whom they are delegating their purchasing agent authority. The purchasing agent authority for the subcontractor becomes effective on the later of the “effective date” or the signature date of the contractor’s or subcontractor’s authorized individual.

If Section B is full and additional delegations are required, it is necessary for the contractor who is delegating his or her authority to complete a new Form 17, Section B and provide a copy of the Form 17 between the exempt governmental unit or exempt nonprofit organization and the contractor. Reproductions of this delegation must be provided to the contractor, who must retain a copy for his or her records, and to the governmental unit or exempt nonprofit organization.

When To Issue. The delegation must be issued to the subcontractor BEFORE the subcontractor annexes any building materials. If the Form 17, Section B, Delegation of Contractor’s Authority is not issued, the Option 2 or Option 3 subcontractor must pay the sales and use taxes on all building materials annexed to real estate before the effective date or signature date on the appointment.

Other Contractor Information

Purchasing Tax Exempt Building Materials and Fixtures. Option 1 and Option 3 contractors who perform construction work for an exempt governmental unit or exempt nonprofit organization can purchase the building materials and fixtures tax exempt by issuing a properly and fully completed Form 13, Section C, Block 1, to its suppliers. It is not necessary for the Option 1 or Option 3 subcontractor to attach a copy of the Form 17 to its Form 13.

Option 2 contractors who perform construction work for an exempt governmental unit or exempt nonprofit organization can purchase the building materials and fixtures tax exempt by issuing a properly and fully completed Form 13, Section C, Block 2, and a copy of the Form 17 to its supplier. This delegation will not allow purchases of building materials and fixtures without payment of the tax by the contractor or subcontractor before the later of the effective date of the appointment or the signature date of the individual authorized to delegate them as a purchasing agent. In addition, the appointment cannot be made after the expiration date of the original appointment.

Form 13 and Form 17 must be retained with the supplier’s and contractor’s records for audit purposes. A contractor may reproduce copies of these documents which can be furnished to the suppliers for each invoice or order made by them.

Invoices from suppliers for the purchase of building materials by a contractor as purchasing agent, or an authorized subcontractor, must clearly identify that the purchase is for the specific Form 17 project.

Option 2 and Option 3 contractors who bill another contractor for work performed for an exempt governmental unit or exempt nonprofit organization are not required to collect sales tax on the amount charged for their contractor labor charges since their labor charges are not subject to tax. They do not need to obtain a Form 13 or Form 17 from the contractor.

Credit/Refund of Sales and Use Tax. Option 2 contractors who have been appointed as a purchasing agent before any materials are annexed, may withdraw tax-paid building materials from inventory that will be annexed to real estate or used to repair property annexed to real estate and receive a credit for the sales or use tax amount previously paid on those materials.

The Option 2 contractor or subcontractor may take a credit either against its current tax liability, or file a [Claim for Overpayment of Sales and Use Tax, Form 7](#), and receive a refund of the sales or use tax paid on those materials.

Tools, Equipment, Supplies, and Taxable Services. The purchase, rental, or lease of tools, supplies, equipment, or taxable services (for example, scaffolding, barricades, machinery, building cleaning services etc.) by a contractor for use to complete an exempt project CANNOT be purchased tax exempt, even if the contractor has been issued a Form 17 for the project.

Penalty. Any person who signs this document with the intent to evade payment of tax is liable for the sales and use tax, interest, and penalty, and may be found guilty of a misdemeanor.

Authorized Signature. The purchasing agent appointment, Section A, must be signed by the proper government official or by an officer of the exempt nonprofit organization or another individual authorized by an attached power of attorney. The delegation of the prime or subcontractor's authority, Section B, must be signed by an owner, partner, corporate officer, or other individual authorized to sign the Delegation of Contractor's Authority.

CONTRACT AGREEMENT

CONTRACT AGREEMENT

THIS AGREEMENT made and entered into this ____ day of _____, 2024, by and between _____, hereinafter called the Contractor, and the City of Grand Island, Nebraska, hereinafter called the City.

WITNESSETH:

THAT, WHEREAS, in accordance with law, the City has caused contract documents to be prepared and an advertisement calling for bids to be published, for construction of **Curb Ramp Project No. 2024-CR-2 CDBG**; and

WHEREAS, the City, in the manner prescribed by law, has publicly opened, examined, and canvassed the proposals submitted, and has determined the aforesaid Contractor to be the lowest responsive bidder, and has duly awarded to the said Contractor a contract therefore, for the sum or sums named in the Contractor's bid, a copy thereof being attached to and made a part of this contract;

NOW, THEREFORE, in consideration of the compensation to be paid to the Contractor and of the mutual agreements herein contained, the parties have agreed and hereby agree, the City for itself and its successors, and the Contractor for itself or themselves, and its or their successors, as follows:

ARTICLE I. That the Contractor shall (a) furnish all tools, equipment, superintendence, transportation, and other construction materials, services and facilities; (b) furnish, as agent for the City, all materials, supplies and equipment specified and required to be incorporated in and form a permanent part of the completed work; (c) provide and perform all necessary labor; and (d) in a good substantial and workmanlike manner and in accordance with the requirements, stipulations, provisions, and conditions of the contract documents as listed in the attached General Specifications and Special Provisions, said documents forming the contract and being as fully a part thereof as if repeated verbatim herein, perform, execute, construct and complete all work included in and covered by the City's official award of this contract to the said Contractor, such award being based on the acceptance by the City of the Contractor's bid;

ARTICLE II. That the City shall pay to the contractor for the performance of the work embraced in this contract and the contractor will accept as full compensation therefore the sum (subject to adjustment as provided by the contract) of _____ **AND XX/100 DOLLARS (\$_____)** for all services, materials, and work covered by and included in the contract award and designated in the foregoing Article I; payments thereof to be made in cash or its equivalent in the manner provided in the General Specifications.

ARTICLE III. The contractor hereby agrees to act as agent for the City in purchasing materials and supplies for the City for incorporation into the work of this project. The City shall be obligated to the vendor of the materials and supplies for the purchase price, but the contractor shall handle all payments hereunder on behalf of the City. The vendor shall make demand or claim for payment of the purchase price from the City by submitting an invoice to the contractor. Title to all materials and supplies purchased hereunder shall vest in the City directly from the vendor. Regardless of the method of payment, title shall vest immediately in the City. The contractor shall not acquire title to any materials and supplies incorporated into the project. All invoices shall bear the contractor's name as agent for the City. This paragraph will apply only to these materials and supplies actually incorporated into and becoming a part of the finished product of **Curb Ramp Project No. 2024-CR-2 CDBG**.

ARTICLE IV. All work associated with the contract shall be completed no later than **October 31, 2024**.

ARTICLE V. The Contractor agrees to comply with all applicable State fair labor standards in the execution of this contract as required by Section 73-102, R.R.S. 1943. The Contractor further agrees to comply with the provisions of Section 48-657, R.R.S. 1943, pertaining to contributions to the Unemployment Compensation Fund of the State of Nebraska. During the performance of this contract, the contractor and all subcontractors agree not to discriminate in hiring or any other employment practice on the basis of race, color, religion, sex, national origin, age or disability. The Contractor agrees to comply with all applicable Local, State and Federal rules and regulations.

ARTICLE VI. GRATUITIES AND KICKBACKS: City Code states that it is unethical for any person to offer, give, or agree to give any City employee or former City employee, or for any City employee or former City employee to solicit, demand, accept, or agree to accept from another person, a gratuity or an offer of employment in connection with any decision, approval, disapproval, recommendation, or preparation of any part of a program requirement or a purchase request, influencing the content of any specification or procurement standard, rendering of advice, investigation, auditing, or in any other advisory capacity in any proceeding or application, request for ruling, determination, claim or controversy, or other particular matter, pertaining to any program requirement or a contract or subcontract, or to any solicitation or proposal therefore. It shall be unethical for any payment, gratuity, or offer of employment to be made by or on behalf of a subcontractor under a contract to the prime contractor or higher tier subcontractor or any person associated therewith, as an inducement for the award of a subcontract to order.

ARTICLE VII. The City of Grand Island, Nebraska operates on a fiscal year beginning October 1st and ending on the following September 30th. It is understood and agreed that any portion of this agreement which will be performed in a future fiscal year is contingent upon the City Council adopting budget statements and appropriations sufficient to fund such performance.

ARTICLE VIII. FAIR EMPLOYMENT PRACTICES: Each proposer agrees that they will not discriminate against any employee or applicant for employment because of age, race, color, religious creed, ancestry, handicap, sex or political affiliation.

ARTICLE IX. LB 403: Every public contractor and his, her or its subcontractors who are awarded an agreement by the City for the physical performance of services within the State of Nebraska shall register with and use a federal immigration verification system to determine the work eligibility status of new employees physically performing services within the State of Nebraska.

IN WITNESS WHEREOF, the parties hereto have executed this Contract Agreement as of the date and year first above written.

CONTRACTOR

By _____

Date _____

Title _____

CITY OF GRAND ISLAND, NEBRASKA,

By _____
Mayor

Date _____

Attest: _____
City Clerk

The contract and bond are in due form according to law and are hereby approved.

Attorney for the City

Date _____

APPENDIX A – TITLE VI NON-DISCRIMINATION -

During the performance of this contract, the contractor, for itself, its assignees and successors in interest (hereinafter referred to as the "contractor") agrees as follows:

- (1) **Compliance with Regulations:** The contractor shall comply with the Regulation relative to nondiscrimination in Federally-assisted programs of the Department of Transportation (hereinafter, "DOT") Title 49, Code of Federal Regulations, Part 21, and the Federal Highway Administration (hereinafter "FHWA") Title 23, Code of Federal Regulations, Part 200 as they may be amended from time to time, (hereinafter referred to as the Regulations), which are herein incorporated by reference and made a part of this contract.
- (2) **Nondiscrimination:** The Contractor, with regard to the work performed by it during the contract, shall not discriminate on the grounds of race, color, or national origin, sex, age, and disability/handicap in the selection and retention of subcontractors, including procurements of materials and leases of equipment. The contractor shall not participate either directly or indirectly in the discrimination prohibited by 49 CFR, section 21.5 of the Regulations, including employment practices when the contract covers a program set forth in Appendix B of the Regulations.
- (3) **Solicitations for Subcontractors, Including Procurements of Materials and Equipment:** In all solicitations either by competitive bidding or negotiation made by the contractor for work to be performed under a subcontract, including procurements of materials or leases of equipment, each potential subcontractor or supplier shall be notified by the contractor of the contractor's obligations under this contract and the Regulations relative to nondiscrimination on the grounds of race, color, or national origin, sex, age, and disability/handicap.
- (4) **Information and Reports:** The contractor shall provide all information and reports required by the Regulations or directives issued pursuant thereto, and shall permit access to its books, records, accounts, other sources of information, and its facilities as may be determined by the City of Grand Island or the FHWA to be pertinent to ascertain compliance with such Regulations, orders and instructions. Where any information required of a contractor is in the exclusive possession of another who fails or refuses to furnish this information the contractor shall so certify to the City of Grand Island, or the FHWA as appropriate, and shall set forth what efforts it has made to obtain the information.
- (5) **Sanctions for Noncompliance:** In the event of the contractor's noncompliance with the nondiscrimination provisions of this contract, the City of Grand Island shall impose such contract sanctions as it or the FHWA may determine to be appropriate, including, but not limited to:
 - (a.) withholding of payments to the contractor under the contract until the contractor complies, and/or
 - (b.) cancellation, termination or suspension of the contract, in whole or in part.
- (6) **Incorporation of Provisions:** The contractor shall include the provisions of paragraphs (1) through (6) in every subcontract, including procurements of materials and leases of equipment, unless exempt by the Regulations, or directives issued pursuant thereto.

The contractor shall take such action with respect to any subcontract or procurement as the City of Grand Island or the FHWA may direct as a means of enforcing such provisions including sanctions for non-compliance: Provided, however, that, in the event a contractor becomes involved in, or is threatened with, litigation with a subcontractor or supplier as a result of such direction, the contractor may request the City of Grand Island to enter into such litigation to protect the interests of the City of Grand Island, and, in addition, the contractor may request the United States to enter into such litigation to protect the interests of the United States.

NAMED EQUIPMENT / SUBCONTRACTORS

Bidders shall enter the names of manufacturers for items of equipment proposed to be furnished. Substitutions will not be permitted unless the proposed equipment does not meet the specifications or the manufacturer of the proposed equipment is unable to meet delivery requirements of the construction schedule.

Acceptance of the named equipment as part of the bid shall not constitute a waiver of specifications covering such equipment. Final acceptance shall be based upon review of shop drawings of the proposed equipment.

<i>Equipment</i>	<i>Manufacturer</i>

LIST OF SUBCONTRACTORS

Bidders shall enter the names of subcontractors to be used in performing the work. If any of the following work is to be self-performed, fill in the name of the Bidder. Bidder certifies that all subcontractors listed are eligible to perform the work. The City reserves the right to reject any listed subcontractor(s).

<i>Subcontractor's Work</i>	<i>Subcontractor's Name</i>

Failure to furnish the information requested on this form may be cause for rejection of the bid.

Bidder: _____

DIVISION I

GENERAL SPECIFICATIONS

**APPLICABLE TO ALL
CONSTRUCTION CONTRACTS**

**DIVISION I
GENERAL SPECIFICATIONS**

C O N T E N T S

Section	Description
1	DEFINITIONS OF WORDS AND TERMS
1.01	Abbreviations
1.02	Advertisement
1.03	Award
1.04	Backslope
1.05	Bidder
1.06	Calendar Day
1.07	Change Order
1.08	City
1.09	Contract
1.10	Contract or Performance Bond
1.11	Contract Item
1.12	Contract Period
1.13	Contractor
1.14	Cul-de-sac Street
1.15	Culvert
1.16	Easement (Right-of-way)
1.17	Employee
1.18	Engineer
1.19	Extra Work
1.20	Holidays
1.21	Inspector
1.22	Laboratory
1.23	Notice to Bidders
1.24	Plans
1.25	Project
1.26	Bid
1.27	Bid Form
1.28	Bid Guarantee
1.29	Right-of-way
1.30	Special Provisions
1.31	Specifications
1.32	Subcontractor
1.33	Superintendent
1.34	Supplemental Agreements
1.35	Supplemental Specifications
1.36	Surety
1.37	Work
1.38	Working Day
1.39	Working Drawings
1.40	Work Order
1.41	Completion of the Work and Formal Acceptance by the City
1.42	Final Acceptance of the Work

Revised 1-25-2011

Section	Description
2	BID REQUIREMENTS AND CONDITIONS
2.01	Contents of Bid Forms
2.02	Interpretation of Quantities in Bid Forms
2.03	Examination of Plans, Specifications, Special Provisions and Site of Work
2.04	Preparation of Bid
2.05	Statement of Bidder's Plant and Financial Conditions
2.06	Certified, Check, Cashier's Check, or Bid Bond
2.07	Filing of Bid
2.08	Withdrawal of Bid
2.09	Public Opening of Bids
2.10	Material Guarantee
3	AWARD AND EXECUTION OF THE CONTRACT
3.01	Consideration of Bids
3.02	Award of Contract
3.03	Cancellation of Award
3.04	Return of Bid Guarantee
3.05	Performance Bond
3.06	Contract Documents
	Revised 1-25-2011
3.07	Failure to Execute Contract
4	SCOPE OF WORK
4.01	Intent of Plans and Specifications
4.02	Special Work
4.03	Increased or Decreased Quantities of Work
	Revised 1-25-2011
4.04	Extra Work
4.05	Maintenance of Detours
4.06	Temporary Traffic Control
	Revised 1-25-2011
4.07	Maintenance of Traffic
4.08	Street Closing
4.09	Miscellaneous Removal Items
4.10	Removal and Replacement of Property Stakes
4.11	Removal and Disposal of Structures and Obstructions
4.12	Rights In and Use of Materials Found on the Right-of-Way
4.13	Construction and Demolition Debris
4.14	Final Cleaning Up
4.15	Right-of-way
4.16	Railroad Crossings
4.17	Safety and Health Regulations for Constructions
5	CONTROL OF WORK
5.01	Authority of Engineer
5.02	Plans and Working Drawings
5.03	Alteration of Plans or of Character of Work
5.04	Coordination of Plans, Specifications, Special Provisions, and Supplemental Specifications
5.05	Cooperation of Contractor

Section	Description
5.06	Surveys
5.07	Authority and Duties of Inspector
5.08	Inspection of Work
5.09	Removal of Defective Work
5.10	Final Inspection
6	CONTROL OF MATERIALS
6.01	Source of Supply and Quality Requirements
6.02	Methods of Sampling and Testing, and Cited Specifications
6.03	Storage of Materials
6.04	Unacceptable Materials
6.05	Guarantee
6.06	"Or Equal" Clause
7	LEGAL RELATIONS AND RESPONSIBILITY TO THE PUBLIC
7.01	Laws to be Observed
7.02	State and City Fair Labor Standards
7.03	Anti-discrimination
7.04	Permits
7.05	Patents
7.06	Restoration of Surface Opened by Permit
7.07	Safety, Health, and Sanitation
7.08	Barricades and Warning Signs
7.09	Use of Explosives
7.10	Claims for Labor and Materials
7.11	Contractor's Insurance
7.12	Proof of Carriage of Insurance
7.13	Contractor's Responsibility for Utility Property and Services
7.14	No Waiver of Legal Rights
7.15	Exposure of Pipe or Manholes
8	PROSECUTION AND PROGRESS
8.01	Subletting or Assigning of Contract
8.02	Prosecution of Work
8.03	Limitations of Operations
8.04	Methods and Equipment
8.05	Temporary Suspension of Work
8.06	Liquidated Damages
8.07	Extension of Contract Period
8.08	Abrogation
8.09	Termination of Contractor's Responsibility
9	MEASUREMENT AND PAYMENT
9.01	Payments
9.02	Payments Withheld
9.03	Acceptance and Final Payment
9.04	Payment for Extra Work

**DIVISION I
GENERAL SPECIFICATIONS**

SECTION 1 - DEFINITIONS OF WORDS AND TERMS

Wherever in these specifications or in other contract documents the following terms or pronouns in place of them are used, the intent and meaning shall be interpreted as follows:

1.01 Abbreviations.

AASHTO	American Association of State Highway And Transportation Officials
ASTM	American Society for Testing and Materials
ANSI	American National Standards Institute
AWWA	American Water Works Association
AREA	American Railway Engineering Association
AWS	American Welding Society
AAN	American Association of Nurserymen

1.02 Advertisement. The advertisement for work or materials on which bids are to be received.

1.03 Award. The decision of the City to accept the bid of the lowest responsible bidder for the work, subject to the execution and approval of a satisfactory contract therefor and bond to secure the performance thereof and to such other conditions as may be specified or otherwise required by law.

1.04 Backslope. The sloping surface of a cut, the downward inclination of which is toward the roadbed.

1.05 Bidder. Any individual, firm, or corporation formally submitting a bid for the work contemplated, acting directly or through a duly authorized representative.

1.06 Calendar Day. Every day shown on the calendar, Sundays and holidays included.

1.07 Change Order. A written order to the Contractor, signed by the Engineer, ordering a change in the work from that originally shown in the plans and specifications.

1.08 City. The word "City" as used in these specifications refers to the City of Grand Island, Nebraska, acting through its City Council.

1.09 Contract. The written agreement executed between the City and the Contractor, covering the performance of the work and the furnishing of labor and materials, by which the Contractor is bound to perform the work and furnish the labor and materials, and by which the City is obligated to compensate Contractor therefor at the mutually established and accepted rate or price.

The contract shall include the "Notice to Bidders", these specifications, the Contractor's bond, the general and detailed plans, the bid, special provisions, and supplemental agreements.

1.10 Contract or Performance Bond. The approved form of security, executed by the Contractor and their surety or sureties, guaranteeing complete execution of the contract and all supplemental agreements pertaining thereto and the payment of all legal debts pertaining to the construction of the project.

1.11 Contract Item. An item of work specifically described and for which a price, either unit or lump sum, is provided. It includes the performance of all work and the furnishing of all labor, equipment, and materials described in the text of a specification item included in the contract or described in any subdivision of the text of the supplemental specification or special provision of the contract.

1.12 Contract Period. The period from the date specified in the contract for the commencement of the work to the date specified for its completion, both dates inclusive.

1.13 Contractor. The party of the second part to the contract; the individual, firm, or corporation undertaking the execution of the work under the terms of the contract and acting directly or through Contractor's agents or authorized employees.

1.14 Cul-de-sac Street. A local street open at one end only and with special provision for turning around.

1.15 Culvert. Any structure not classified as a bridge which provides an opening under any street.

1.16 Easement (Right-of-way). A right acquired by public authority to use or control property for a designated purpose.

1.17 Employee. Any person working on the project mentioned in the contract of which these specifications are a part, and who is under the direction or control or receives compensation from the Contractor or Contractor's subcontractor.

1.18 Engineer. The City Engineer, acting either directly or through an assistant or other representative duly authorized by the City Engineer, such assistant or representative acting within the scope of the particular duties assigned or with the authority given.

1.19 Extra Work. Work performed by the Contractor in order to complete the contract in an acceptable manner but for which there is no basis of payment provided in the contract.

1.20 Holidays. In the State of Nebraska, holidays occur on: January 1, Martin Luther King, Jr. Day in January, Presidents' Day in February, Arbor Day in April, Memorial Day in May, July 4, Labor Day in September, Columbus Day in October, Veterans Day and Thanksgiving Day in November, and December 25. If any of said dates fall on Sunday, the following Monday shall be a holiday. If any of said dates fall on Saturday, the previous Friday shall be a holiday.

1.21 Inspector. An authorized representative of the Engineer assigned to make detailed inspection of any or all portions of the work performed and materials furnished by the Contractor.

1.22 Laboratory. The testing laboratory of the City or any other testing laboratory which may be designated by the Engineer.

1.23 Notice to Bidders. The provisions, requirements, and instructions pertaining to the work to be awarded, manner and time of submitting bids , quantities of the major items or work required, as prepared for the information of bidders.

1.24 Plans. The official plans, profiles, typical cross sections, general cross sections, working drawings, and supplemental drawings, or exact reproductions thereof, approved by the Engineer, which show the location, character, dimensions, and details of the work to be done, and which are to be considered as a part of the contract supplementary to these specifications.

1.25 Project. All work necessary to be performed under the contract.

1.26 Bid. The offer of the bidder, submitted on the prescribed bid form, to perform the work and to furnish the labor and materials at the prices quoted by the bidder.

1.27 Bid Form. The approved form on which the City requires formal bids be prepared and submitted.

1.28 Bid Guarantee. The security furnished by the Bidder with Bidder's bid for a project as a guarantee that Bidder will enter into a contract for the work if said bid is accepted.

1.29 Right-of-way. The land area which is reserved or secured by the City for constructing the work or for obtaining material therefor.

1.30 Special Provisions. Special directions, provisions, or requirements peculiar to the project under consideration and not otherwise thoroughly or satisfactorily detailed or set forth in the specifications.

1.31 Specifications. The general term comprising all the directions, provisions, and requirements contained herein, together with such as may be added or adopted as supplemental specifications or special provisions, all of which are necessary for the proper performance of the contract.

1.32 Subcontractor. Any individual, firm, or corporation to whom the Contractor, with the written consent of the City, sublets any part of the contract.

1.33 Superintendent. The representative of the Contractor, present on the work at all times during progress, authorized to receive and fulfill instructions from the Engineer and capable of superintending the work efficiently.

1.34 Supplemental Agreements. Written agreements executed by the Contractor and the City subsequent to having entered into the contract, covering alterations in the plans or unforeseen items of construction.

1.35 Supplemental Specifications. Specifications adopted subsequent to the publication of this book. They generally involve new construction items or substantial changes in the approved specifications. Supplemental specifications shall prevail over those published in this book whenever in conflict therewith.

1.36 Surety. The corporate body bound with and for the Contractor for the acceptable performance of the contract, the completion of the work, and for payment of all just claims arising therefrom.

1.37 Work. Work shall be understood to mean the furnishing of all labor, materials, equipment, and other incidentals necessary or convenient to the successful completion of the project by the Contractor and the carrying out of all the duties and obligations imposed by the contract.

1.38 Working Day. Any day, except Saturdays, Sundays, and Nebraska holidays, on which the Contractor is not prevented by weather, soil conditions, or other conditions beyond the Contractor's control, adverse to the current controlling operation or operations, as determined by the Engineer, from proceeding with at least 80 percent of the labor and equipment force normally engaged in such operation or operations for at least 50 percent of the full number of hours in Contractor's normal daily schedule. Also, a Saturday, Sunday, or Nebraska holiday on which any work is performed on the current controlling operation or operations unless the Contractor is prevented by weather, soil conditions, or other conditions beyond the Contractor's control as determined by the Engineer, from proceeding for at least 50 percent of the full number of hours in their normal schedule with 80 percent of the normal working force.

1.39 Working Drawings. Stress sheets, shop drawings, erection plans, falsework plans, framework plans, cofferdam plans, bending diagrams for reinforcing steel, or any other supplementary plans for similar data which the Contractor is required to submit to the Engineer for approval.

1.40 Work Order. A written order signed by the Engineer, of a contractual status requiring performance by the Contractor without negotiation of any sort and may involve starting, resuming, or the suspension of work. (Not to be confused with extra work order).

1.41 Completion of the Work and Formal Acceptance by the City. Whenever the term "completion of the work and formal acceptance by the City" is used, it refers to and means the formal acceptance of the work by the Engineer and the City at the time the Contractor has all work under the contract completed and in place.

1.42 Final Acceptance of the Work. Whenever the term "final acceptance of the work" is used, it refers to and means the time when the Engineer and the City finally accept the work. The contractor guarantee shall remain in force from the City's final acceptance for a period of one year.

Revised 1-25-2011

SECTION 2 – BID REQUIREMENTS AND CONDITIONS

2.01 Contents of Bid Forms. Bidders will be furnished with bid forms which will state the location and description of the contemplated work and will show the estimate of the various quantities and kinds of work to be performed or materials to be furnished, with a schedule of items for which unit bid prices are asked, the time in which the work must be completed and the date, time, and place of opening bids. All special provisions and required provisions will be grouped together and bound with or included through reference in the bid form.

2.02 Interpretation of Quantities in Bid Forms. The quantities listed in the bid forms are to be considered as approximate, unless otherwise provided by special provision. It is understood that the quantities of work to be done and materials to be furnished may each be increased, diminished, or omitted as hereinafter provided without in any way invalidating the unit bid prices, except as provided in the section in these specifications entitled Increased or Decreased Quantities of Work.

2.03 Examination of Plans, Specifications, Special Provisions, and Site of Work. The bidder is required to examine carefully the site, the bid, plans, specifications, special provisions, and contract form for the work contemplated, and it will be assumed that the bidder has investigated and is satisfied as to the conditions to be encountered, as to the character, quality, and quantities of work to be performed and materials to be furnished and as to the requirements of these specifications, the special provisions, and contract. It is mutually agreed that the submission of a bid shall be considered prima facie evidence that the bidder has made such examination.

2.04 Preparation of Bid. Bidders shall submit their bids on blank forms furnished by the Engineer with the full name and address and the place of business or residence of the bidder. If the bidder is co-partnership, the signature shall be by a member of the firm with the names and addresses of each member. If the bidder is a corporation, the signature shall be by an officer of the corporation in the corporate name and with the corporate name and the corporate seal attached thereto.

All blank spaces in the form shall be fully filled; numbers shall be stated in legible figures and writing when required; the signature shall be longhand; and the complete form shall be without interlineation, alteration, or erasure.

No oral, telegraphic, or telephonic bids or modifications will be considered.

When certain alternative prices, for both increasing and decreasing the cost, are required, as called for in the bid sheet, it must be understood that all materials and workmanship required shall be the best of their respective kinds and in all cases shall correspond with similar work herein specified and, if accepted, the work shall be done under the general terms of the specifications.

2.05 Statement of Bidder's Plant and Financial Conditions. Each bidder may submit with bid and, in any event, the City may, after bids are opened and prior to award of contract, require any bidder to submit the following data:

1. A statement that the bidder maintains a permanent place of business and address thereof;
2. A statement of equipment which the bidder proposes to use on the project, together with a statement noting that equipment previously mentioned which the bidder owns and that which bidder does not own but is certain bidder will be able to rent or otherwise procure for use on the project;
3. A financial statement, duly sworn to in a form approved by the City, listing assets and liabilities;
4. Statement listing projects of similar nature which the bidder has constructed or in the construction of which the bidder was actively engaged in a responsible capacity. Any bidder may be required by the City to submit additional data to satisfy the City that such bidder is prepared to fulfill the contract if it is awarded to them.

2.06 Certified Check, Cashier's Check, or Bid Bond. Each bidder must submit with the bid a certified check, cashier's check, or bid bond in the amount of not less than five percent (5%) of the amount bid, drawn to the order of the City Treasurer, Grand Island, Nebraska, guaranteeing the execution of the contract and bond required within ten (10) days of the notification of award. Any certified check must be issued by a bank in the State of Nebraska.

2.07 Filing of Bid. Bidders shall submit bid data on items offered in the Bid by filling in one set of data sheets supplied by the Engineering Department. The bid sheets shall be filled out legibly in black ink to permit reproduction.

Bidder security, when required, shall be enclosed in a special envelope marked, "BIDDER SECURITY/BID FOR _____." The envelope shall contain only a cashier's check or bidder's bond. This special envelope shall be attached to a sealed envelope containing the bid, filled out specifications, descriptive information drawings, qualification list and any other bid materials. This second envelope shall be marked "BID FOR _____." Bids of an incomplete nature or subject to multiple interpretations may, at the option of the Purchaser, be rejected as being irregular.

All bids shall be filed with the City at the place designated in the Notice to Bidders, prior to the time advertised for the opening of bids.

2.08 Withdrawal of Bid. A bidder will be permitted to withdraw said bid unopened after it has been submitted, if bidder's request for withdrawal is made in writing and delivered personally by the bidder or bidders' authorized representative prior to the time specified for opening of bids.

2.09 Public Opening of Bids. Bids will be publicly opened and read at the time and place stipulated in the Notice to Bidders.

2.10 Material Guarantee. Before any contract is awarded, the bidder may be required to furnish a complete statement of the origin, composition, and manufacture of any or all materials to be used in the construction of the work together with samples, which samples may be subjected to the test provided for in these specifications to determine their quality and fitness for the work.

SECTION 3 - AWARD AND EXECUTION OF THE CONTRACT

3.01 Consideration of Bids. After the bids are opened and read, they will be compared on the basis of the summation of the products and the quantities shown in the bid schedule by the unit bid prices. The results of such comparisons will be immediately available to the public.

The right is reserved to reject any and all bids and to waive technical errors as may be deemed best for the interest of the City.

3.02 Award of Contract. In the award of contract, consideration will be given not only to the prices bid but also the mechanical and other equipment available to the bidder, the financial responsibility of the bidder, and bidder's ability and experience in the performance of like or similar contracts.

Award of contracts will be made as promptly as practical after bids have been opened and read. The City reserves the right to delay the award for such time as is needed for the consideration of the bids and for the receipt of concurrence in recommended contract awards from other governmental agencies whose concurrence may be required.

3.03 Cancellation of Award. The City reserves the right to cancel the award of any contract at any time before execution of the said contract by all parties without any liability against the City.

3.04 Return of Bid Guarantee. Bid guaranties will be returned to the unsuccessful bidders by mail promptly after the signing of the contract has been made. Return to the successful bidder will be made after the signing of the contract and filing of the contract bond.

3.05 Performance Bond. The Contractor shall furnish a performance bond with a company having the approval of the City in an amount of 100 percent of the contract price guaranteeing complete and faithful performance of the contract, payment of all bills of whatever nature which could become a lien against the property, and guaranteeing replacement of defective materials and workmanship for a period of one year after completion of the contract.

3.06 Contract Documents. Three (3) copies of Contract Documents shall be made, executed, and distributed as follows:

One copy to City Clerk
One copy to Contractor One copy to Engineer

The following documents are a part of the contract:

*Notice to Bidders	*General Specifications
*Instructions to Bidders	*Special Provisions
*Bid	*Supplemental Specifications
*Detailed Specifications	*Performance Bond
*Contract	*Additional Drawings as required to make clear the intent of the contract

Revised 1-25-2011

3.07 Failure to Execute Contract. Failure to execute a contract and file an acceptable performance bond as provided herein within ten (10) days from date of award shall be just cause for the annulment of the award and the forfeiture of the certified check or cashier's check to the City, not as a penalty but in liquidation of damages sustained.

SECTION 4 - SCOPE OF WORK

4.01 Intent of Plans and Specifications. The intent of the plans and specifications is to provide for the construction and completion of every detail of the work described therein. It shall be understood by the Contractor that Contractor will furnish all labor, materials, tools, transportation, and supplies required for all or any part of the work to make each item complete in accordance with the spirit of the contract. It is understood that the apparent silence of the specifications as to any detail or the apparent omission of a detailed description concerning any point shall be regarded as meaning that only the best general practice is to prevail and that only materials and workmanship of the first quality are to be used.

For the purpose of design and the preparation of the Engineer's Estimate, the City may perform a reasonable amount of exploratory work to gain information relative to surface and subsurface conditions relating to type of soil, moisture content, and types and extent of rock strata.

This information when shown on the plan represents to the best of the City's knowledge conditions as of the date the survey was made. The appearance of this information on the plan will not constitute a guarantee that conditions other than those indicated will not be encountered at the time of construction.

The bidder may utilize this information as they see fit. Any bidder interested in the work is authorized to make whatever investigation they considers advisable.

In making such additional investigation, the bidder is directed to the Engineer for information relating to available right-of-way. If there are, at that time, any parcels of land over which the City does not have jurisdiction, right of entry must be secured by the prospective bidder from those authorized to grant such permission. Investigational work, performed by a prospective bidder on existing streets open to traffic, shall be performed in compliance with the

requirements of the current Manual on Uniform Control Devices for Street and Highways. All such additional investigational work shall be performed without costing or obligating the City in any way.

4.02 Special Work. Any conditions not covered by these standard specifications are stated in the special provisions.

4.03 Increased or Decreased Quantities of Work. The Engineer reserves the right to alter the quantities of contract items for which there are bid prices. Such increases or decreases in quantities shall be made as the City considers necessary or desirable without waiving or invalidating any of the provisions of the contract. All such alterations must be ordered in writing and a supplemental agreement must be executed with the Contractor for the item or items involved when such alterations involve an increase or decrease of more than 20 percent of the total cost of the work of any group of the contract calculated from the original bid quantities and the contract unit prices. The Contractor shall not start work on any alteration requiring a supplemental agreement until the agreement setting forth an equitable adjustment of compensation, satisfactory to both parties, shall have been executed by the Engineer and the Contractor and approved by City Council.

Revised 1-25-2011

4.04 Extra Work. The City reserves the right to order the performance of work of a class not contemplated in the bid but which may be considered necessary to complete satisfactorily the work included in the contract. Such extra work will be paid for as provided in these specifications under section entitled Payment for Extra Work.

4.05 Maintenance of Detours. Unless so required by the plans or the special provisions, the Contractor will not be required to assume any responsibility in connection with the maintenance or marking of suitable detours.

4.06 Temporary Traffic Control. Part VI of the Manual of Uniform Traffic Control Devices (MUTCD) is the national standard for work zone traffic control. The current version that has been adopted by the Nebraska Department of Roads is also applicable to the City of Grand Island and shall be followed.

Any City crews, contractors, utility company, or any other person, firm or corporation performing work within the right-of-way of any public street, public way, or alley in the City of Grand Island shall install and maintain Temporary Traffic Control (TTC) in accordance with the standards of the MUTCD.

The Public Works Director or their representative shall have the authority to direct corrective actions for any TTC not in compliance with the MUTCD and these provisions. These actions may include suspending operations and requiring removal of all equipment or materials from the right-of-way.

If the TTC is left in place longer than four (4) hours and no personnel are on the site, the individual responsible for installing the TTC shall provide telephone numbers of personnel who will be available on a 24 hours per day, seven days per week basis to the Public Works Director. These individuals shall be responsible for repair, correction, replacement and maintenance of the traffic control devices. These individuals shall perform inspections of the TTC at the site a minimum of twice during the day and once during the night every day until the work is completed and the right-of-way is cleared.

Subsidiary: Unless contract pay items are included with the bid specifications, direct payment for providing, installing, maintaining, and performing site inspections of TTC devices will not be made but are considered subsidiary to other items for which direct payment is

provided. When the contract contains a pay item for TTC, the NDOR standard items, specifications, etc. will be used.

Revised 1-25-2011

4.07 Maintenance of Traffic. The Contractor shall conduct the work so as to interfere as little as possible with public travel, whether vehicular or pedestrian. Whenever it is necessary to cross, obstruct, or close roads, driveways, and walks, whether public or private, the Contractor shall, at Contractor's expense, provide and maintain suitable and safe bridges, detours, or other temporary expedients for the accommodation of public and private travel, and shall give reasonable notice to owners of private drives before interfering with them. Such maintenance of travel will not be required when the Contractor has obtained permission from the owner or tenant of private property or from the authority having jurisdiction over public property involved to obstruct traffic at the designated area.

4.08 Street Closing. In the event it is deemed necessary for the Contractor to close any streets during the execution of said work, the Contractor shall notify the owner of such street closing 72 hours in advance, prior to any street closing due to open cut street crossing.

4.09 Miscellaneous Removal Items. The Contractor shall inform the Engineer sufficiently ahead of construction so landowners can be notified to remove small trees, shrubs, and fences from the construction limits if the landowners desire to save them.

4.10 Removal and Replacement of Property Stakes. If it is necessary to remove any property corners or markers during construction operations, the Contractor shall notify the Engineer so the Engineer can establish reference ties. Any markers removed without notice to the Engineer shall be replaced at the Contractor's expense in accordance with the proper land surveying techniques.

4.11 Removal and Disposal of Structures and Obstructions. The Contractor for bridge and culvert work shall remove any existing structure or part of structure that in any way interferes with the new construction. If specific payment for such work has not been provided in the contract, it will be paid for as extra work.

The Contractor shall remove any materials or structures found on the right-of-way which are not to remain in place or which have not been designated for use in the new construction. The removal and disposal of pipe culverts will not be paid for directly but shall be considered as incidental work, and the cost of such removal and disposal shall be considered to be included in the contract price for other items. Pipe culverts shall be removed by methods that will cause a minimum of damage to the pipe culverts. The removal and disposal of bridges or other masonry or monolithic concrete construction will be paid for. If the contract does not contain an item for such work, it will be paid for as extra work.

4.12 Rights In and Use of Materials Found on the Right-of-way. Unless stated to the contrary in the contract documents, all materials, such as stone, gravel, sand, timber, and structures or parts of structures, found on the right-of-way of the street or on land acquired for the work, are the property of the City or the owner of the fee title to the land, and shall not be used or destroyed by the Contractor without special permission from the Engineer. When the Contractor is permitted to use materials found on the right-of-way, any excavations that they make below the grade elevation shall be backfilled with other suitable materials so the finished street will conform to the grade shown on the plans. No extra compensation will be allowed for such backfilling.

When rock excavation is encountered, any portion of rock excavation which would otherwise be deposited in waste areas and not be incorporated in the embankments may be processed and used, royalty free, by the Contractor in any other portion of the construction in which material of that quality would be acceptable. No deduction will be made from excavation quantities for rock so used.

4.13 Construction and Demolition Debris. Debris from any City awarded project, as well as Municipal Solid Waste (that is not recycled), shall be disposed of at the City's Solid Waste facilities.

4.14 Final Cleaning Up. Upon completion of the work and before acceptance and final payment, the Contractor shall clean the street, borrow pits, and all ground occupied by Contractor in connection with the work of all rubbish, excess materials, falsework, temporary structures, and equipment, and all parts of the work, shall be left in a neat and presentable condition.

When required in the plans, the Contractor shall, at Contractor's expense, replace waste material or stripping back into borrow and material pits as directed by the Engineer. Trees, tree stumps and material placed on property adjacent to the street during the execution of the work shall be disposed of by the Contractor.

4.15 Right-of-way. Right-of-way for the work will be provided without cost to the Contractor. Right-of-way will be made available to the Contractor on or before the date specified for the commencement of the work unless a later date for the right-of-way to be made available to the Contractor is designated in the contract documents.

4.16 Railroad Crossings. Whenever the work involves construction with which railroad companies are concerned, the performance of the work is contingent upon arrangements with the railroad companies for the proposed construction. No claims will be allowed for loss or damage caused by failure to complete such arrangements.

4.17 Safety and Health Regulations for Construction. Occupational Safety and Health Standards for the Construction Industry (29 CFR Part 1926) with amendments as of February 1, 1999 promulgated by the Occupational Safety and Health Administration, United States Department of Labor, Washington, D.C. are incorporated herein as a part of the contract documents.

SECTION 5 - CONTROL OF WORK

5.01 Authority of Engineer. The Engineer will have general supervision of the work and will decide any questions that arise with reference to the intent of the contract documents and compliance therewith. Said Engineer will relay all questions relating to materials, work, progress, disputes and mutual rights between contractors, fulfillment of contract, and compensation, in accordance with the provisions of these specifications.

5.02 Plans and Working Drawings. The approved plans will be supplemented by such working drawings as are necessary to adequately control the work. It is mutually agreed that all authorized alterations affecting the requirements and information given in the approved plans shall be in writing.

Working drawings for any structure shall consist of such detailed plans as may be required of the Contractor for the prosecution of the work. These are not included in the plans

furnished by the Engineer. They shall include shop details, erection plans, masonry, and form work. The Engineer's prior approval of the shop details must be obtained before any fabrication work involving these plans is performed. Erection plans, masonry layout diagrams, and plans for cribs, cofferdams, falsework, centering, and form work, as well as any other working drawings not previously mentioned, may be required of the Contractor and shall be subject to the Engineer's approval.

No changes shall be made in any plan or drawing after it has been approved except by consent or direction of the Engineer in writing. It is expressly understood that the approval by the Engineer of the Contractor's working drawings will not relieve the Contractor from any responsibility.

The contract price shall include the cost of furnishing all working drawings, and the Contractor will be allowed no extra compensation for such drawings.

Shop plans shall be made on 22"x36" sheet with ½" margin on all sides except the left which shall be 2". The margin lines shall measure 21"x33 ½". The marking shall be in accordance with the special plans or as may be required by the Engineer. All blueprint plans which are furnished to the Engineer shall be clear and distinct and acceptable to the Engineer and shall be neatly trimmed. The Contractor shall furnish the Engineer as many extra copies of working drawings as the Engineer may direct.

The Engineer may require reproducible prints of all approved shop plans, which shall be furnished by the Contractor without cost to the Engineer. Such reproducible prints shall not be folded but shall be mailed in tubes sized to accommodate these plans without injuring them. No preliminary working drawings will be accepted by the Engineer unless they have been carefully checked by the Contractor. Drawings showing gross errors will be returned for recheck before examination by the Engineer. The name of the shop or company furnishing the drawings shall be on the tracing.

5.03 Alteration of Plans or of Character of Work. The Engineer shall have the right to make alterations in plans or character of work as may be considered necessary or desirable during the progress of the work to satisfactorily complete the proposed construction. Such alterations shall not be considered as a waiver of any conditions of the contract or invalidate any of the provisions thereof.

5.04 Coordination of Plans, Specifications, Special Provisions, and Supplemental Specifications. These specifications, the supplemental specifications, the plans, special provisions, and all supplementary documents are essential parts of the contract, and a requirement occurring in one is as binding as though occurring in all. They are intended to be complementary and to describe and provide for a complete work. In case of discrepancy, figured dimensions shall govern over scaled dimensions, plans shall govern over specifications, special plans shall govern over standard plans, supplemental specifications shall govern over standard specifications, and special provisions shall govern over specifications, supplemental specifications, and the plans.

5.05 Cooperation of Contractor. The Contractor will be supplied with a minimum of two sets of approved plans and contract assemblies, including special provisions, one set of which the Contractor shall keep available on the work at all times.

The Contractor shall give the work the constant attention necessary to facilitate the progress thereof and shall cooperate with the Engineer and other contractors in every way possible.

The Contractor shall at all times have at the work site, as Contractor's agent, a competent superintendent capable of reading and thoroughly understanding the plans and specifications, thoroughly experienced in the type of work being performed, who shall receive

instructions from the Engineer or Engineer's authorized representatives. The superintendent shall have full authority to execute the orders or directions of the Engineer without delay, and to promptly supply materials, equipment, tools, labor, and incidentals as may be required. Such superintendence shall be furnished irrespective of the amount of work sublet.

5.06 Surveys. Lines and elevations shall be established by the Engineer before the work commences and the Contractor shall obtain lines and elevations from the points so set by the Engineer. The Contractor shall furnish all stakes necessary for lines and elevations and cooperate with the Engineer in setting same.

5.07 Authority and Duties of Inspector. The City may appoint inspectors to represent the Engineer in the inspection of all materials used in and all work done under the contract. Such inspection may extend to any part of the work and to the preparation or manufacture of the materials to be used. The inspector will not be permitted to modify in any way the provisions of the contract documents, nor to delay the work by failing to inspect materials and work with reasonable promptness. An inspector is placed at the work site to keep the Engineer informed as to its progress and the manner in which it is being done and to call the Contractor's attention to any infringements of the contract documents. The inspector will not act as foreman or perform other duties for the Contractor nor improperly interfere with the management of the work. They will not be authorized to approve or accept any portion of the work. In case of dispute between the Contractor and the inspector as to quality of materials or the manner of performing the work, the inspector shall have the authority to reject materials or suspend the work until the question at issue can be decided by the Engineer. Written notice of the suspension of work will be given to the Engineer and the Contractor.

5.08 Inspection of Work. The Contractor shall furnish the Engineer with every reasonable facility for ascertaining whether the work is being performed in conformance with the contract documents. At any time before acceptance of the work, upon request of the Engineer, the Contractor shall remove or uncover such portions of the finished work as the Engineer may direct. After examination has been made, the Contractor shall restore such portions of the work to the standard required by the contract documents.

If the work thus exposed or examined proves acceptable, the uncovering or removing and replacing of the covering or the restoring of the parts removed shall be paid for as extra work, except that no payment will be made for the work involved in checking the smoothness of pavement surfaces. If the work thus exposed and examined proves unacceptable, the Contractor shall replace the defective work in accordance with the specifications and will be paid only the contract price for the work as finally accepted. Work done or materials used without the Engineer having been afforded ample opportunity to provide suitable inspection may be ordered removed and replaced at the Contractor's expense or may be excluded from the quantities measured for payment.

5.09 Removal of Defective Work. Any defective work shall be removed and replaced at the Contractor's expense. Should the Contractor fail or refuse to remove defective work when so ordered by the Engineer, the Engineer shall have authority to order the Contractor to suspend further operations and may withhold payment on estimates until such defective work has been removed and replaced in accordance with the plans and specifications. Continued failure or refusal on the part of the Contractor to correct defective work promptly shall be sufficient cause for the City to declare the contract in default and to proceed to have the work completed in accordance with these specifications under section entitled Abrogation.

5.10 Final Inspection. Upon notification by the Contractor or Contractor's authorized representative that the work is completed, the Engineer shall make prompt final inspection of each item of work included in the contract. If the work is found to not be in accordance with the contract documents, the Contractor will be advised as to the particular defects to be remedied.

SECTION 6 - CONTROL OF MATERIALS

6.01 Source of Supply and Quality Requirements. The materials used on the work shall meet all quality requirements of the contract. In order to expedite the inspection and testing of materials, the Contractor shall notify the Engineer of Contractor's proposed sources of materials prior to delivery. At the option of the Engineer, approval of the source or approval of materials at the source prior to delivery may be required. If it is found after trial that sources of supply for previously approved materials do not produce specified products or when conditions are such that the use of unfit materials cannot be prevented except by extraordinary inspection methods, the Contractor shall

furnish materials from other sources. Before delivery is started and at any time during the process of preparation and use, the materials shall be subject to the approval of the Engineer.

6.02 Methods of Sampling and Testing, and Cited Specifications. Sampling and testing of all materials and the laboratory methods and testing equipment required under these specifications shall be in accordance with the latest published standard method of the AASHTO, except as otherwise provided.

The sampling and testing of all materials not covered by the AASHTO, but not otherwise provided for, shall conform to the latest published standard or tentative methods of the ASTM.

6.03 Storage of Materials. The Contractor shall be responsible for the care and storage of materials delivered at the work site or purchased for use thereon. Any material that has been delivered to the work site and has become damaged before actual incorporation in the work may be rejected by the Engineer even though it may previously have been accepted. Stored materials shall be so located as to facilitate thorough inspection.

6.04 Unacceptable Materials. All materials not conforming to the requirements of the specifications at the time they are to be used shall be considered as unacceptable, and all such materials will be rejected and shall be removed immediately from the site of the work unless otherwise instructed by the Engineer. No rejected materials, the defects of which have been corrected, shall be used until approval has been given.

6.05 Guarantee. The Contractor shall be responsible for any and all defects which may develop in any part of the entire installation furnished by said Contractor and, upon receipt of written notice from the Engineer, shall immediately replace and make good without expense to the City any such faulty part or parts and damage done by reason of same during a period of one (1) year from the date of formal acceptance of the installation (except when specific guarantee for another length of time is elsewhere specified).

The acceptance of the installation, or any part of it, shall not act to waive this liability on the part of the Contractor.

Upon completion and formal acceptance of the work, the Contractor may furnish a satisfactory bond in an amount of fifteen percent (15%) of contract price to insure the provisions of this guarantee. Otherwise, the original bond shall remain in full force and effect until final acceptance of the work, which acceptance shall be made one (1) year after the formal acceptance of the work as provided herein.

6.06 "Or Equal" Clause. Whenever, in any section of the contract documents, plans, or specifications, any article, material, or equipment is defined by describing a proprietary product or by using the name of a manufacturer or vendor, the term "or approved equal", if not inserted, shall be implied. The specific article, material, or equipment mentioned shall be understood as indicating the type, function, minimum standard or design, efficiency, and quality desired and shall not be construed in such a manner as to exclude manufacturer's products of comparable quality, design, and efficiency. The Engineer shall determine the acceptability of articles, materials, or equipment proposed as equals.

SECTION 7 - LEGAL RELATIONS AND RESPONSIBILITY TO THE PUBLIC

7.01 Laws to be Observed. The Contractor shall keep fully informed of and, at all times, shall observe and comply with all Federal and State laws, all local bylaws, ordinances, and regulations, and all orders and decrees of bodies or tribunals having any jurisdiction or authority which in any manner affect those engaged or employed on the project, or which in any way affect the project. The Contractor shall protect and indemnify the City and its representatives against any claim or liability arising from or based on the violation of any such law, ordinance, regulation, order, or decree, whether by said Contractor or Contractor's employees. It shall be the responsibility of the Contractor to provide all safeguards, safety devices, and protective equipment and to take any other needed actions as are reasonably necessary to protect the life and health of employees on the project.

7.02 State and City Fair Labor Standards. The Contractor agrees to comply with all applicable State and City fair labor standards in the execution of the contract, including compliance with Section 73-102, R.R.S. 1943. The Contractor further agrees to comply with the provisions of Section 48-657, R.R.S. 1943, pertaining to contributions to the Unemployment Compensation Fund of the State of Nebraska. In addition, the Contractor agrees to comply with the provisions of Section 52-118, R.R.S. 1948, pertaining to payment of all labor performed and for payment for materials and equipment rental which is actually used in performing this contract.

7.03 Anti-discrimination. During the performance of the work, the Contractor agrees not to discriminate against any employee or application for employment because of race, color, age, religion, sex, or national origin.

7.04 Permits. The Contractor shall procure and pay for all permits, licenses, and bonds necessary for the prosecution of Contractor's work and/or required for municipal, State, and Federal regulations and laws.

7.05 Patents. The Contractor and the surety in all cases shall indemnify and save harmless the City for any costs, expenses, and damages which it may be obligated to pay by reason of any such infringement at any time during the prosecution of or after the completion of the project.

7.06 Restoration of Surfaces Opened by Permit. Upon the presentation of a duly authorized and satisfactory permit from the City which provides that all necessary repair work will be paid for by the party to whom such permit is issued, the Engineer may authorize the Contractor to allow parties bearing such permits to make openings in the street. The Contractor shall, when ordered by the Engineer in writing, make in an acceptable manner all necessary repairs due to such openings, and such necessary work ordered by the Engineer shall be paid for on the basis of "Extra Work" as provided for in these specifications and shall be subject to the same conditions as original work performed.

7.07 Safety, Health, and Sanitation. In the performance of the contract, the Contractor shall comply with all applicable Federal, State, and local laws governing safety, health, and sanitation. The Contractor shall furnish such additional safeguards, safety devices, and protective equipment and shall take actions as the Engineer may determine as being reasonably necessary to protect the life and health of Contractor's employees and the public.

7.08 Barricades and Warning Signs. Except as otherwise provided specifically in this section, the Contractor shall provide and maintain barricades, danger and warning signs, and suitable and efficient lights, and shall take every reasonable precaution to prevent accidents. The name of the Contractor shall be clearly visible on the barricades. The Contractor shall provide, at their own expense, such watchmen as are necessary to protect their equipment and to maintain proper lights.

Watchmen who may be necessary to direct traffic or prevent travel on any portion of the street shall be provided by the Contractor on written order from the Engineer. Unless the contract specifically provides that such watchmen are to be furnished by the Contractor, this expense shall be paid for as provided in "Extra Work."

7.09 Use of Explosives. When the use of explosives is necessary for the prosecution of the work, the Contractor shall use the utmost care not to endanger life or property. All explosives shall be stored in a secure manner, and storage places shall be clearly marked "DANGER--EXPLOSIVES."

7.10 Claims for Labor and Materials. The Contractor shall indemnify and save harmless the City from all claims for labor and materials furnished under this contract. When requested by the City, the Contractor shall submit satisfactory evidence that all persons, firms, or corporations who have done work or furnished materials under this contract, for which the City may become liable under the laws of the State, have been fully paid or satisfactorily secured. In case such evidence is not furnished or is not satisfactory, an amount will be retained from money due the Contractor which, in addition to any other sums that may be retained, will be sufficient, in the opinion of the City, to meet all claims of the persons, firms, and corporations as aforesaid. Such sum shall be retained until the liabilities as aforesaid are fully discharged or satisfactorily secured.

7.11 Contractor's Insurance. The Contractor shall secure and maintain throughout the duration of this contract insurance, from companies authorized to do business in Nebraska, of such types and in such amounts as may be necessary to protect themselves and the interests of the City against all hazards or risks of loss as hereinafter specified. This insurance shall cover all aspects of the Contractor's operations and completed operations. The form and limits of such insurance, together with the underwriter thereof in each case, shall be approved by the City, but regardless of such approval it shall be the responsibility of the Contractor to maintain adequate insurance coverage at all times. Failure of the Contractor to maintain adequate coverage shall not relieve them of any contractual responsibility or obligation. Minimum insurance coverage shall be the amounts stated herein or the amounts required by applicable law, whichever are greater.

1. "Worker's Compensation and Employer's Liability." This insurance shall protect the Contractor against all claims under applicable State worker's compensation laws. This insurance shall provide coverage in every state in which work for this project might be conducted. The Contractor shall also be protected against claims for injury, disease, or death of employees which, for any reason, may not fall within the provisions of a worker's compensation

law. This policy shall include an "all states" endorsement. The liability limits shall be not less than the following:

Worker's Compensation	Statutory Limits
Employer's Liability	\$100,000 each accident
	\$100,000 each employee
	\$500,000 policy limit

2. "Business Automobile Liability." This insurance shall be written in comprehensive form and shall protect the Contractor, Contractor's employees, or subcontractors from claims due to the ownership, maintenance, or use of a motor vehicle. The liability limits shall be not less than the following:

Bodily Injury & Property Damage	\$500,000 Combined Single Limit
---------------------------------	---------------------------------

3. "Comprehensive General Liability." The comprehensive general liability coverage shall contain no exclusion relative to explosion, collapse, or underground property. The liability limits shall be not less than the following:

Bodily Injury & Property Damage	\$ 500,000 each occurrence
	\$1,000,000 aggregate

4. "Umbrella Liability Insurance." This insurance shall protect the Contractor against claims in excess of the limits provided under employer's liability, comprehensive automobile liability, and commercial general liability policies. The umbrella policy shall follow the form of the primary insurance, including the application of the primary limits. The liability limits shall not be less than the following:

Bodily Injury & Property Damage	\$1,000,000 each occurrence
	\$1,000,000 general aggregate

5. Additional Requirements. The City may require insurance covering a Contractor or Subcontractor more or less than the standard requirements set forth herein depending upon the character and extent of the work to be performed by such Contractor or Subcontractor.

Insurance as herein required shall be maintained in force until the City releases the Contractor of all obligations under the contract.

The Contractor shall provide and carry any additional insurance as may be required by special provisions of these specifications.

6. Certificate of Insurance. Satisfactory certificates of insurance shall be filed with the City prior to starting any work on this contract. The certificates shall show the City as an additional insured on all coverage except Workers Compensation. The certificate shall state that thirty (30) days written notice shall be given to the City before any policy is cancelled (strike the "endeavor to" wording often shown on certificate forms). If the Contractor cannot have the "endeavor to" language stricken, the Contractor may elect to provide a new certificate of insurance every thirty (30) days during the contract. The Contractor shall immediately notify the City if there is any reduction of coverage because of revised limits or claims paid which affect the aggregate of any policy.

7.12 Proof of Carriage of Insurance. Satisfactory certificates of insurance shall be filed with the City prior to starting any construction work on this contract. The certificates shall show the City as "Additionally Insured." The certificates shall state that thirty (30) days written notice shall be given to the City before any policy covered thereby is changed or canceled (strike the "endeavor to" wording often shown on certificate forms).

7.13 Contractor's Responsibility for Utility Property and Services. At points where the Contractor's operations are adjacent to properties of railway, telegraph, telephone, and power companies or adjacent to other property to which damage might result, work shall not be commenced until all arrangements necessary for the protection thereof have been made.

The Contractor shall cooperate with the owners of any underground or overhead utility lines in their removal and rearrangement operations in order that these operations may progress in a reasonable manner, that duplication of rearrangement work may be reduced to a minimum, and that services rendered by those parties will not be unnecessarily interrupted.

In the event of interruption to water or utility services as a result of accidental breakage or as result of being exposed or unsupported, the Contractor shall promptly notify the proper authority. Contractor shall cooperate with said authority in the restoration of service as promptly as possible. In no case shall interruption to water service be allowed to exist outside of working hours. Fire hydrants shall be kept accessible to the Fire Department at all times and no materials shall be kept or stockpiled within fifteen (15) feet of any fire hydrant.

The Contractor must cooperate with the utility companies and schedule work in such a manner as to protect the existing utility facilities until the facilities are abandoned or replacement facilities are completed. In instances where partial grading is necessary before a utility can install its facilities, the Contractor shall consult with the utility and plan the work so reasonable time can be allowed the utility for completing its work.

7.14 No Waiver of Legal Rights. The City shall not be precluded or estopped by any measurement, estimate, or certificate made either before or after the completion and acceptance of the work and payment therefor from showing the true amount and character of the work performed and materials furnished by the Contractor, nor from showing that such measurement, estimate, or certificate is untrue or is incorrectly made, nor that the work or materials do not in fact conform to the contract. The City shall not be precluded or estopped, notwithstanding any such measurement, estimate, or certificate and payment in accordance therewith, from recovering from the Contractor or Contractor's sureties, or both, such damage as it may sustain by reason of Contractor's failure to comply with the terms of the contract. Neither the acceptance by the City or any representative of the City, nor any payment for or acceptance of the whole or any part of the work, nor any extension of time, nor any possession taken by the City shall operate as a waiver of any portion of the contract or of any power herein reserved or of any right to damages. A waiver of any breach of the contract shall not be held to be a waiver of any other or subsequent breach.

7.15 Exposure of Pipe or Manholes. The Contractor shall conduct the work at all times in such a manner as will insure no disruption to the normal function of the sanitary sewer collection system. Particular attention shall be paid to the threat of introduction of storm water or other waters to the piping and manholes of the collection system. The Contractor shall take whatever precautions are necessary, such as, but not limited to installation of plugs in exposed pipes and manholes when work is not in progress or when leaving the work site. The Contractor will be held responsible for damages which may occur to either the collection system or to private property through introduction of storm water or other waters to exposed piping or manholes relating to the construction work.

SECTION 8 - PROSECUTION AND PROGRESS

8.01 Subletting or Assigning of Contract. The Contractor will not be permitted to sublet, assign, sell, transfer, or otherwise dispose of the contract or any portion thereof or Contractor's right, title, or interest therein or to either legally or equitably assign any of the money payable under Contractor's contract or claim thereto without the written consent of Contractor's surety and the Engineer. The Contractor will not be relieved of any responsibility through any of the above actions.

8.02 Prosecution of Work. The bid for each project will show the contract period. The progress of the work shall be at a rate sufficient to complete the contract within the contract period. If it appears that the rate of progress is such that the contract will not be completed within the contract period or if the work is not being executed in a satisfactory and workmanlike manner, the City may order the Contractor to take such steps as it considers necessary to complete the contract within the period of time specified or to prosecute the work in a satisfactory manner. If the Contractor fails to comply with such order within two (2) weeks after receipt of the order, Contractor shall automatically be disqualified from receiving any additional contract awards, and the City shall have the right to declare the contract in default and to complete the work in accordance with these specifications under section entitled Abrogation.

The Contractor's sequence of operations shall be such as to cause as little inconvenience to the general public as possible.

The Contractor will be granted additional and suitable time for the prosecution of the work, as was lost by reason of a delay or delays attributable to other parties authorized to do work on the project over which the Contractor had no control or jurisdiction, as provided in these specifications under section entitled Extension of Contract Period.

8.03 Limitations of Operations. The Contractor shall conduct the work at all times in such a manner and in such sequence as will insure the least interference with traffic. Contractor shall have due regard to the location of detours and to the provisions of handling traffic. Contractor shall not open up work to the prejudice of work already started, and the Engineer may require the Contractor to finish a section on which work is in progress before work is started on any additional section. The Contractor shall so conduct operations and maintain the work in such condition that adequate drainage shall be in effect at all times.

8.04 Methods and Equipment. The methods, equipment, and appliances used shall produce a satisfactory quality of work and shall be adequate to maintain the schedule of progress specified. Equipment used on any portion of the project shall be such that no injury to the roadway, adjacent property, or other streets will result from its use.

When the methods and equipment to be used by the Contractor in accomplishing the construction are not prescribed in the contract, the Contractor is free to use any methods or equipment that is demonstrated to accomplish the contract work in conformity with the requirements of the contract to the satisfaction of the Engineer.

When the contract specifies that the construction be performed by the use of certain methods and equipment, such methods and equipment shall be used unless others are authorized by the Engineer. If the Contractor desires to use a method or type of equipment other than those specified in the contract, a request may be made to the Engineer for authority to do so. The request shall be in writing and shall include a full description of the methods and equipment proposed to be used and an explanation of the reasons for desiring to make the change. If approval is given, it will be on the condition that the contractor will be fully responsible for producing construction work in conformity with contract requirements. If, after trial use of the substituted methods or equipment, the Engineer determines that the work produced does not

meet contract requirements, the Contractor shall discontinue the use of the substitute method or equipment and shall complete the remaining construction with the specified methods and equipment. The Contractor shall remove the deficient work and replace it with work of specified quality or take such other corrective action as the Engineer may direct. No change will be made in basis of payment for the construction items involved nor in contract time as result of authorizing a change in methods or equipment under these provisions.

8.05 Temporary Suspension of Work. Work shall be suspended wholly or in part when, in the opinion of the Engineer, weather or other conditions are unfavorable to its satisfactory prosecution. Work shall also be suspended at the direction of the Engineer pending settlement of disputes arising out of failure of the Contractor to comply with the provisions of the contract. Written notice of suspension of work shall be given by the Engineer. When the conditions causing suspension no longer exist, such written notice shall be given to the Contractor by the Engineer. Promptly after such written notice, the Contractor shall resume prosecution of the work as provided in these specifications under section entitled Prosecution of Work.

8.06 Liquidated Damages. Time is an essential element of the contract, and it is important that the work be pressed vigorously to completion.

For each calendar day that any work shall remain uncompleted after the end of the contract period, the amount per calendar day specified in the bid form will be assessed, not as a penalty but as predetermined and agreed liquidated damages. The City will prepare and forward to the Contractor an invoice for such liquidated damages. The final payment will be withheld until payment shall have been made of this invoice.

Due account shall be taken of any adjustment of the contract period granted under the section of these specifications entitled Extension of Contract Period.

The assessment of liquidated damages for failure to complete the work within the contract period shall not constitute a waiver of the City's right to collect any additional damages which the City may sustain by failure of the Contractor to carry out the terms of the contract.

8.07 Extension of Contract Period. An extension of the contract period may be granted by the City for any of the following reasons:

1. Additional work resulting from a modification of the plans for the project
2. Delays caused by the City
3. Other reasons beyond the control of the Contractor which, in the City's judgment, would justify such extension.

No extension of contract period will be allowed for variations between contract quantities and actual quantities which cannot be predetermined and which amount to less than twenty percent (20%) of the contract quantities.

8.08 Abrogation. If the Contractor abandons, sublets, or assigns the work under this contract without the consent of the City, or if Contractor fails to give - personal attention to it, or if it is the Engineer's opinion, and is so certified in writing to the Contractor and the City, that the Contractor is violating any of the provisions of this contract or that Contractor is not prosecuting the work in good faith or at the rate of progress specified, or that Contractor has unnecessarily or unreasonably delayed or neglected the work or any part of it, written notice to that effect is to be given to the Contractor by the Engineer. After such notice, no materials or equipment shall be removed from the work. If, within five (5) days thereafter, the Contractor does not take steps, which in the judgment of the Engineer will insure the satisfactory completion of the work, then the City may declare this contract null and void and the security forfeited and may notify the Contractor in writing to discontinue the work or any part of it; thereupon ceasing the Contractor's right of possession of the ground and of all materials and equipment thereon. The City then, at

their option, may enter upon and take possession of the work with all materials, supplies, and equipment remaining thereon and by contract or otherwise, as the City may determine, may complete the work or the part of it designated and charge the expense thereof to the Contractor using any materials or equipment found on the site. The expense so charged, together with all damages incurred, will be deducted from any funds due or to become due under this contract and, should the unexpended balance of these funds be insufficient, the excess shall be at the cost of the Contractor and sureties on the Contractor's bond. Neither completion of a part of the work nor the extension for any reason of the time of the completion of the work is to be considered a waiver of this right to abrogate the contract for abandonment, delay, or unsatisfactory work.

8.09 Termination of Contractor's Responsibility. The contract shall be considered completed when the work has been accepted in writing by the City. Such acceptance shall release the Contractor from all further obligation with respect thereto, except as to conditions and requirement set forth in Contractor's bond.

SECTION 9 - MEASUREMENT AND PAYMENT

9.01 Payments. Payments for estimated work completed will be made only on certificates of the Engineer at a regular City Council meeting.

The City, at its discretion, may include in such estimates payments for materials that will eventually be incorporated in the project, provided that such materials are suitably stored on the site of the project at the time of preparing estimates for payment. Such payment is to be based upon the estimated value thereof as ascertained by the Engineer. Such material when so paid for by the City shall not be removed from the project without consent of the City and, in case of default on the part of the Contractor; the City may use or cause to be used by others these materials in construction of the project.

The City will retain five percent (5%) of the estimated amount of work executed in an approved manner and of the approved materials and apparatus suitably stored on the site.

Payment of the retained five percent (5%) will be made within sixty (60) days after the formal approval and acceptance by the Engineer of all apparatus, materials, and work embraced in the contract.

9.02 Payments Withheld. The City may withhold or, on account of subsequently discovered evidence, nullify the whole or a part of any certificate to such extent as may be necessary to protect itself from loss on account of:

1. Defective work not remedied
2. Claims filed or reasonable evidence indicating probable filing of claims
3. Failure of the Contractor to make payments properly to subcontractors or for materials or labor
4. A reasonable doubt that the contract can be completed for the balance then unpaid
5. Damage to another contractor.

When the above grounds are removed, payment shall be made for amounts withheld because of them.

9.03 Acceptance and Final Payment. If final inspection reveals that all details of the work have been completed satisfactorily, the Engineer shall tentatively accept the work, in writing, relieving the Contractor of further responsibility for the care and maintenance of the completed work and, provided that all equipment and materials have been removed from the right-of-way, shall also relieve the Contractor of further public liability. As soon as possible after tentative

acceptance of the work, the Engineer shall measure the completed work and compute the quantities of work for which payment is to be made. Before final settlement is made, the City shall be satisfied with the completed work. When the Engineer is satisfied that all items of the work have been found to be consistent with the terms of the contract and specifications, a final estimate including the retained percentage due the Contractor shall be released for payment. Release of the final estimate shall constitute final acceptance of the work.

All prior partial estimates and payments shall be subject to correction in the final estimate and payment.

Extra work - See these specifications under section entitled Extra Work.

9.04 Payment for Extra Work. The Contractor will receive and accept payment for work performed under the contract as follows:

1. Items of work performed which are covered by definite prices stipulated in the contract. For all items of work performed which are covered by definite unit prices or lump sum amounts specified in the contract, the Contractor shall receive and accept compensation at the rate specified in the contract.

2. Extra work ordered by the Engineer, of a quality or class not covered by the contract, will be paid for at an agreed price. For extra work ordered by the Engineer and performed on an agreed price basis, the Engineer and the Contractor shall enter into a written agreement, and have City Council approval, before such work is undertaken. This written agreement shall describe the extra work that is to be done and shall specify the agreed price or prices therefore.

Revised 1-25-2011

DIVISION I-A

SPECIAL PROVISIONS

CURB RAMP PROJECT NO. 2024-CR-2 CDBG
VARIOUS LOCATIONS

DIVISION IA - SPECIAL PROVISIONS
SECTION 200 – GENERAL

200.01 General Description of Work. The work to be performed under the provisions of these contract documents consists of furnishing all materials, equipment, tools, and the performance of all necessary labor to complete the construction, including all work appurtenant thereto of Portland Cement Concrete sidewalk in Curb Ramp Project No. 2024-CR-2 CDBG.

200.02 Location of Work is at Intersections Listed as Follows.

SECTION A – WHEELER AVENUE

- **Section #A1.** Wheeler Avenue & 18th Street
- **Section #A2.** Wheeler Avenue & 18th Street Mid Block
- **Section #A3.** Wheeler Avenue & 19th Street
- **Section #A4.** Wheeler Avenue & 20th Street
- **Section #A5.** Wheeler Avenue & 21st Street
- **Section #A6.** Wheeler Avenue & 22nd Street
- **Section #A7.** Wheeler Avenue & 23rd Street

SECTION B – GRACE ABBOTT PARK

- **Section #B1.** Cleburn Street & 18th Street
- **Section #B2.** Cleburn Street & 17th Street
- **Section #B3.** Elm Street & 17th Street
- **Section #B4.** Cedar Street & 17th Street
- **Section #B5.** Cedar Street & State Street
- **Section #B6.** State Street – North Side

SECTION C -

- **Section #C1.** Greenwich Street & 12th Street

200.03 Specifications. The specifications which govern the materials and equipment to be furnished and the work to be performed under this contract are listed herein and in Division I – General Provisions, Division IA – Special Provisions, Division II – Portland Cement Concrete, Division III – Curb and Gutter, Sidewalks and Driveway, Division V – Storm and Sanitary Sewer, Applicable Standard Plan Drawings. If there is information described in any of the divisions that is in conflict with information in Division IA – Special Provisions, the information in the Special Provisions shall govern the contract.

200.04 Exempt Sales Certificate. The Contractor performing work under this contract will be issued a Purchasing Agent Appointment and Sales Certificate signed by the authorized representative of the City. This is to be used by the Contractor when purchasing tangible personal property to be actually incorporated into the contract work. It does not apply to either (1) the purchase of materials to be used, but not incorporated into the contract work, including but not limited to form lumber, scaffolding, etc. of (2) the purchase or rental of machinery, equipment or tools owned or leased by the Contractor and used in performing the contract work. The Contractor may produce copies of the Purchasing Agent Appointment and Exempt Sales Certificate to furnish their supplies on each invoice or order.

200.05 Provisions for Traffic. The Contractor shall conduct their work so as to interfere as little as possible with public travel, whether vehicular or pedestrian. Whenever it is necessary to cross, obstruct, or close roads, driveways, and walks, whether public or private, the Contractor shall, per bid item, provide and maintain suitable and safe detours or other temporary expedients for the accommodation of public and private travel. The Contractor shall give reasonable advance notice to the affected residents of private drives. The Contractor shall provide and maintain barricades, warning signs, or flashing lights in accordance with the typical traffic control plan and the

Manual on Uniform Traffic Control Devices (MUTCD). The engineer shall have the authority to direct corrective actions for temporary traffic control not in compliance with the plans or MUTCD, including suspending operation and requiring removal of all equipment and materials from the right-of-way. A lump sum payment will be made for traffic provisions. The Contractor is required to work under traffic (both vehicular and pedestrian) and is expected to create as little delay and confusion as possible. Contractor shall maintain a clean and safe work area while on site, particularly since pedestrian traffic will be prevalent during construction activities.

200.06 Design Mix Alternates. Portland Cement Concrete used for pavement, curb, curb and gutter, driveway, sidewalk and concrete not being a pre-cast or pre-stressed product, shall be Class 47-B Modified per Division II of these specifications. As an alternate, the Contractor may use Class 47-B Modified with Fly-Ash per the specification of the State of Nebraska, Department of Roads. The Contractor shall inform the Engineer of which design mix will be used prior to commencing with the actual construction. The City reserves the right to designate the mix to be used at any time during construction if any problems should arise which can be attributed to the mix design.

SECTION 201 – PAYMENT ITEMS

201.01 Mobilization. Shall include all costs for bonding an insurance, establishing temporary facilities, as required, temporary fencing, job trailers, prospecting for and exposing existing utilities, moving construction equipment and materials to and from the site, installation, start-up, and all appurtenances related to the work not otherwise specifically called out. The pay item is lump sum, with an equitable amount to be withheld until demobilization after final completion of the work.

201.02 Earthwork. All earthwork, including excavation, fill, embankment, subgrade preparation, and hauling and stockpiling any excess excavation will not be paid for separately, but shall be considered subsidiary to the items for which direct payment is made.

201.03 Remove Walk. Remove Walk shall be measured and paid for at the contract unit price per square feet, including full compensation for all safety, equipment, material, labor, loading, hauling and disposal of sidewalk pavement. Existing sidewalk pavement is assumed to be four (4) inches thick. No additional payment will be made for variable thicknesses. Removal of sidewalk curb shall be surfaced measured, as square feet, and paid for at the contract unit price ‘Remove Walk.’ No additional payment will be made for the thickness of the curb.

~~**201.04 Remove Brick Walk.** Remove Brick Walk shall be measured and paid for at the contract unit price per square feet, including full compensation for all safety, equipment, material, labor, loading, hauling and disposal of brick sidewalk pavement. The removal of brick walk will be surfaced measured, and shall include the underlying base course regardless of thickness or number of layers.~~

201.05 Remove Pavement. Remove Pavement shall be measured and paid for at the contract unit price per square yard, including full compensation for all safety, equipment, material, labor, loading, hauling and disposal of pavement. Remove Pavement shall be surfaced measured, include both Portland cement concrete pavement and asphalt cement pavement, and no additional payment will be made for variable thicknesses. Removal of curb and gutter shall be surfaced measured, as square yards, and paid for at the contract unit price ‘Remove Pavement.’ No additional payment will be made for the thickness of the curb.

~~**201.06 Remove Concrete Pole Base.** Remove Concrete Pole Base shall be measured and paid for at the contract unit price per each, including full compensation for all safety, equipment, material, labor, loading, hauling and disposal of pavement and rebar. Concrete and rebar shall be removed 3 feet below existing ground and backfilled with suitable soil. Dimensions of concrete pole base are unknown.~~

~~**201.07 Remove Concrete Barrier Curb.** Remove Concrete Curb Wall shall be measured and paid for at the contract unit price per lineal feet, including full compensation for all safety, equipment, material, labor, loading, hauling and disposal of pavement and rebar. Concrete barrier curb wall shall be completely removed, include all~~

~~foundation concrete and rebar. Concrete Barrier Curb is identified as NDOT Concrete Barrier Curb Standard Plan 301 R2 (Assume height 20" width 9").~~

201.08 Saw Cut. Saw Cutting pavement shall be measured and paid for at the contract unit price per lineal foot, including full compensation for all safety, equipment, material and labor. No additional payment will be made for variable thickness. Pavement saw cut shall be full depth.

201.09 Build Walk. Build Walk shall be measured and paid for at the contract unit price per square feet, including full compensation for all safety, equipment, material, labor, Portland cement concrete pavement, forming, reinforcement, curing compounds, contraction and expansion joints, joint sealing compounds, concrete additives, finishing, edging, and subgrade preparation. Extra depth concrete at driveways and back of curbs will not be paid for directly and shall be considered subsidiary to the pay item 'Build Walk.' Build Walk pavement shall conform to Section 200.06 – Design Mix Alternatives of these special provisions.

201.10 Build Walk with Curb. Build Walk with Curb shall be measured and paid for at the contract unit price per square feet, including full compensation for all safety, equipment, material, labor, Portland cement concrete pavement, forming, reinforcement, curing compounds, contraction and expansion joints, joint sealing compounds, concrete additives, finishing, edging, and subgrade preparation. Extra depth concrete at driveways and back of curbs will not be paid for directly and shall be considered subsidiary to the pay item 'Build Walk with Curb.' Build Walk with Curb pavement shall conform to Section 200.06 – Design Mix Alternatives of these special provisions.

201.11 Build PCC Stamped Walk. Build PCC Stamped Walk shall be measured and paid for at the contract unit price per square feet, including full compensation for all safety, equipment, material, labor, Portland cement concrete pavement, forming, reinforcement, curing compounds, contraction and expansion joints, joint sealing compounds, concrete additives, finishing, edging, and subgrade preparation. Extra depth concrete at driveways and back of curbs will not be paid for directly and shall be considered subsidiary to the pay item 'Build PCC Stamped Walk.' Pattern for the stamped walk shall be a brick pattern approved by the City of Grand Island. Build PCC Stamped Walk pavement shall conform to Section 200.06 – Design Mix Alternatives of these special provisions.

201.12 Build PCC Pavement. Build PCC Pavement shall be measured and paid for at the contract unit price per square yard, including full compensation for all safety, equipment, material, labor, Portland cement concrete pavement, forming, reinforcement, doweling, curing compounds, contraction and expansion joints, joint sealing compounds, concrete additives, finishing, edging, and subgrade preparation. Build PCC Pavement shall conform to Section 200.06 – Design Mix Alternatives of these special provisions.

201.13 Build Curb. Build Curb shall be measured and paid for at the contract unit price per lineal feet, including full compensation for all safety, equipment, material and labor.

~~**201.14 Build Vertical Curb.** Build Vertical Curb shall be measured and paid for at the contract unit price per lineal feet, including full compensation for all safety, equipment, material and labor. Build Vertical Curb is measured along the top of curb and includes a width of 6" measured from the face of curb.~~

~~**201.15 Build Concrete Barrier Curb.** Build Concrete Curb Wall shall be measured and paid for at the contract unit price per lineal feet, including full compensation for all safety, equipment, material and labor. Build Concrete Barrier Curb shall be measured along the top of curb wall. Concrete Barrier Curb shall be built to match the existing barrier curb, Identified as NDOT Concrete Barrier Curb Standard Plan 301 R12. Refer to current NDOT standard plans for details.~~

201.16 Adjust Manhole to Grade. Adjust Manhole to Grade shall be measured and paid for at the contract unit price per each, including full compensation for all safety, equipment, material, labor, excavation, removal and disposal of excavated materials, backfill with approved materials, compaction, cutting or adjustment of manhole, furnishing and placement of concrete, risers and covers.

201.17 Adjust Inlet. Adjust Inlet shall be measured and paid for at the contract unit price per each, including full compensation for all safety, equipment, material, labor, excavation, removal and disposal of excavated materials, backfill with approved materials, compaction, cutting or adjustment of inlet, furnishing and placement of concrete, brick, mortar, concrete risers, concrete barrels, flat tops, cones, rings, covers, cast iron risers, plastic risers, plastic joint sealant, grout, inlet steps.

~~**201.18 Adjust Valve to Grade.** Adjust Valve to Grade shall be measured and paid for at the contract unit price per each, including full compensation for all safety, equipment, material, labor, excavation, removal and disposal of excavated materials, backfill with approved materials, compaction, cutting or adjustment of valve, furnishing and placement of concrete, risers and covers.~~

201.19 Remove Abandoned Valve Box. Remove Abandoned Valve Box shall be measured and paid for at the contract unit price per each, including full compensation for all safety, equipment, material, labor, excavation, removal and disposal of excavated materials, backfill with approved materials, compaction and cutting/removing valve box.

~~**201.20 Remove Tree.** Remove Tree shall be measured and paid for at the contract unit price per each, including full compensation for all safety, equipment, material, labor, earthwork, excavation, fill, embankment, subgrade preparation, hauling and stockpiling any excess material.~~

~~**201.21 Remove and Reset Street Sign/Post.** Remove and Reset Street Sign/Post shall be measured and paid for at the contract unit price per each, including full compensation for all safety, equipment, material, labor, footings, earthwork, excavation, fill, embankment, subgrade preparation, hauling and stockpiling any excess material.~~

~~**201.22 Remove and Reset Wood Bollards.** Remove and Reset Wood Bollards shall be measured and paid for at the contract unit price per each, including full compensation for all safety, equipment, material, labor, earthwork, excavation, fill, embankment, subgrade preparation, hauling and stockpiling any excess material.~~

201.23 Remove and Reset Landscape Blocks. Remove and Reset Landscape Blocks shall be measured and paid for at the contract unit price per lineal foot, including full compensation for all safety, equipment, material, labor, earthwork, excavation, fill, embankment, subgrade preparation, hauling and stockpiling any excess material.

201.24 Remove and Replace Chain Link Fence. Remove and Replace Chain Link Fence shall be measured and paid for at the contract unit price per lineal foot, including full compensation for all safety, equipment, material, labor, earthwork, excavation, fill, embankment, subgrade preparation, concrete foundations, hauling and stockpiling any excess material. Contract shall salvage material to be reused and supply any additional fencing material required. All new and reused fence posts shall have new concrete foundations placed at the time of fence replacement.

201.25 Sod. Sod shall be measured and paid for at the contract unit price per square yard, including full compensation for all safety, equipment, material and labor. Sod shall conform to Section 302 – Resodding Residential Areas of these Special Provisions.

201.26 Detectable Warning Panels. Detectable Warning Panels shall be measured and paid for at the contract unit price per square feet, including full compensation for all safety, equipment, material and labor. Detectable Warning Panels shall be ADA Solutions, Inc. – Cast In Place Replaceable Tactile, **BRICK RED in color** or an approved equal. ADA Solutions, Inc. – Cast In Place Replaceable Tactile are referenced to describe standard of quality, performance, and desired characteristics and is not intended to restrict or limit competition.

201.27 Landscaping and Sprinkler Repairs. Landscaping and Sprinkler Repairs shall be measured and paid for at the contract unit price per lump sum, including full compensation for all safety, equipment, material, labor, grading, sodding and/or landscaping.

201.28 Traffic Control. Traffic Control shall be measured and paid for at the contract unit price per lump sum, including full compensation for all safety, equipment, material, labor, grading, sodding and/or landscaping.

201.29 Curb Ramps. Concrete for curb ramps will be measured and paid for at the contract unit price for ‘Build Walk’ or ‘Build Walk with Curb.’ The surface of the ramps shall be broomed transversely to the slope of the curb ramp. The flares and wings shall be broomed.

SECTION 202 - COMPLETION

202.01 Completion. All work associated with the contract shall be completed no later than **October 31, 2024**.

SECTION 300 – RESTORATION

300.01 – Restoration – General. The Contractor shall commence restoration activities as soon as practical to minimize disruptions and inconvenience during construction. Restoration shall include, but not be limited to: grading, seeding, sodding, and/or replacement of driveways and roadways. Contractor shall restore the area to the grade and like condition as it existed prior to commencement of construction activities.

~~SECTION 301 – SEEDING; RESIDENTIAL AREAS~~

~~**301.01 – General.** The Contractor shall furnish and supply all labor, materials, and equipment to reseed residential lawns disturbed by the Contractor or other grassed areas as otherwise directed by the Public Works Department. The work shall comply with the requirements of all authorities having jurisdiction. Seeding operations shall be performed only during the periods between April 15 – May 30 or between August 1 – October 1. Seeding operations may occur during other periods only at the express permission of the Public Works Department.~~

~~All materials furnished shall be identified and tagged to insure that species, varieties, boxes, bundles, bales, or other containers are as specified. The information on the label shall cover the botanical genus, species, and common name or variety.~~

~~**301.02 – Seed Materials.** Seed shall be free of noxious weeds and relatively free from all other weeds, and comply with the applicable state and federal seed laws. Seed shall be Nebraska origin or adjoining states, and shall be from field sources grown specifically for the production of sod. The Contractor shall submit to the City a seed tag, which shows the variety, origin, and analysis of the seed.~~

~~Seed mixture shall be for acceptable use in developed residential lawn areas, and shall be comprised of versatile mix of cool season grasses for fairly low maintenance areas:~~

- ~~• Composition: DuraTurf® Plus 2; a mixture of tall fescues, bluegrass, and ryegrasses.~~
- ~~• Application: 10 to 12 lbs/1,000 sq. ft.~~

~~**301.03 – Seedbed.** Areas to be seeded shall be cleared of debris and dead vegetation prior to seeding operations. All other vegetation that will interfere with the seeding operations shall be removed by the Contractor. Care shall be used to avoid injury to trees and shrubs.~~

~~All erosion shall be filled and a three (3) inch surface layer prepared with a loose, moderately course consistency, to allow satisfactory penetration of the ground with the seed drill. Grade, rake and smooth all areas for a free draining and even surface.~~

~~The seedbed adjacent to curbs, walks or other paved areas shall be finished to a grade of one half (1/2) inch below the paved surface.~~

~~Seeding. The seed bed shall be prepared not more than three (3) days prior to the seeding operations by loosening the soil to a depth of two (2) to four (4) inches by disking, harrowing or tilling. Surface crusting caused by water during the interim period shall be loosened prior to the seeding operation.~~

~~The grass mixture will be uniformly drilled where accessible by machinery. On areas not accessible to machinery, the seed may be uniformly broadcast and covered by use of a harrow or rake.~~

~~The grass drill will be designed to handle light fluffy seeds, with double disc furrow openers spaced not more than ten (10) inches apart, and equipped with depth bands to allow placement of the seed from one-quarter (1/4) inch to one-half (1/2) inch deep.~~

~~Work shall not be performed when the ground is frozen, wet, or when an even distribution of seed cannot be obtained.~~

~~**301.04 – Fertilizer.** Starter type fertilizer shall be incorporated into the soil prior to seeding. Fertilizer shall be a commercial turf product containing nitrogen, available phosphoric acid and soluble potash as required, in a recognized plant food form. All fertilizer shall comply with the provisions of the State of Nebraska Fertilizer Act of 1955.~~

~~The fertilizer shall be applied with approved mechanical spreaders at the rates specified and shall cover the entire area uniformly. Caution must be taken in application to insure that the rate does not exceed one pound of nitrogen (N) per 1,000 square feet. Fertilizer will not be paid for separately, but shall be considered subsidiary to the items for which direct payment is made.~~

~~**301.05 – Mulching.** Areas to be mulched will be the same as the seeded area. If hydro mulch is used, it shall be evenly applied to all seeded areas at the minimum rate of 45 lbs per 1,000 square feet with a 3% tackifier and shall be applied immediately after seed application.~~

~~If peat moss is used, it shall be evenly applied to all seeded areas at the minimum rate of one (1) cubic yard per 1,000 square feet. The peat moss will be pulverized, will not be less than 60% decomposed organic matter by weight, and have a pH from four (4) to six (6).~~

~~All materials used as mulch will be free from all noxious weed, seed bearing stalks, or roots and shall be inspected and approved by the Public Works Department representative. Mulch will not be paid for separately, but shall be considered subsidiary to the items for which direct payment is made.~~

~~**301.06 – Establishment, Acceptance, and Guarantee Period.** Thirty (30) days after completion of seeding operations, the Public Works Department representative will inspect the seeded area(s) for determination of establishment and acceptability.~~

~~The Contractor will be notified in writing when their establishment responsibilities have been accepted.~~

~~The guarantee period for seeded areas shall begin at the date of acceptance. The Contractor shall guarantee all material to be in healthy and flourishing condition for a period of sixty (60) days from date of acceptance.~~

~~In areas of deficiencies, a list of locations will be provided to the Contractor for reseeded. The Contractor shall reseed such areas without additional cost to the City, and as soon as weather conditions permit, with materials of the same species that have been planted.~~

~~Reseeded areas shall be subject to all requirements and specifications stated herein. The guarantee for reseeded shall be extend for a period of sixty (60) days from date of their acceptance~~

SECTION 302 – RESODDING RESIDENTIAL AREAS

302.01 – General. Established residential lawns, public easements, or as otherwise directed by the Public Works Department, shall be resodded in accordance with the following specifications.

302.02 – Time of Sodding. Sodding operations shall be performed only during the periods between March 1 – June 15; or between August 1 – October 15. Sodding operations may occur during other periods only at the express permission of the Public Works Department. Sodding shall not be performed when the ground is frozen or weather conditions are not favorable for growth as determined by the Public Works Department.

302.03 – Sod Requirements. Sod shall be from approved field sources. The sod shall be a first class representation of normal species or varieties of bluegrass/fescue blend. The sod shall have been grown from culturally planted seed specifically for the production of sod and shall have been maintained by acceptable methods for the production of sod.

The sod shall be mowed and raked to remove stems, sticks, and clippings prior to cutting. The sod shall be cut to a depth of approximately three-quarters of an inch. Sod shall be free of noxious weeds and relatively free from all other weeds. Extreme care shall be taken in cutting, handling, transporting and laying the sod to avoid unnecessary damage to and loss of earth from the roots of the sod. Sod shall not have dry or dead edges.

302.04 – Soil Preparation. Areas that are to be sodded shall be clear of debris and dead vegetation prior to the preparation of the sod bed. The sod shall not have a crusted appearance. All erosion shall be filled prior to laying the sod and loose earth shall be firmed.

302.05 – Fertilizer. Starter type fertilizer shall be incorporated into the soil prior to sodding the area. Fertilizer shall be a commercial turf product containing nitrogen, available phosphoric acid and soluble potash as required, in a recognized plant food form. All fertilizer shall comply with the provisions of the State of Nebraska Fertilizer Act of 1955.

The fertilizer shall be applied with approved mechanical spreaders at the rates specified and shall cover the entire area uniformly. Caution must be taken in application to insure that the rate does not exceed one pound of nitrogen (N) per 1,000 square feet. Fertilizer will not be paid for separately, but shall be considered subsidiary to the items for which direct payment is made.

302.06 – Laying the Sod. The sod bed shall be thoroughly dampened prior to placing sod. The sod shall be laid over the area in strips edge to edge in a compact mass. The sod shall be laid approximately 1-inch below adjoining ground surfaces and flush with adjoining sod. Sod shall be rolled one time with an approved sod roller.

302.07 – Establishment, Acceptance, and Guarantee Period. The Contractor will be responsible for watering each sodded area(s) once during the mid-morning and again late afternoon for a period of fourteen (14) days following the initial sodding operation.

The Contractor shall notify the Public Works Department when sodding operations are complete for inspection of the work and establishment of the acceptance date. The guarantee period shall be thirty (30) days from the date of acceptance. No partial acceptance will be made.

If areas show thin, weak or dead sod, a list of will be provided to the Contractor for resodding. The Contractor shall remove and replace with fresh sod such areas without additional cost to the City, and as soon as weather conditions permit, with materials of the same species that have been placed. The guarantee period for resodded areas shall be extended an additional thirty (30) days from date of acceptance.

SECTION 303 – BASIS OF PAYMENT

303.01 – General. Payment shall be made for seeding and sodding of the various types that are complete, accepted, and passed the guarantee period at the contract unit price as full compensation for all labor, equipment, tools, materials.

No separate payment shall be made for soil preparation.

DIVISION II

PORTLAND CEMENT CONCRETE PAVEMENT

**DIVISION II
PORTLAND CEMENT CONCRETE PAVEMENT**

C O N T E N T S

Section	Description
10	SCOPE OF WORK
11	MATERIALS
11.04	Cement--47-B (Modified) and ABX (Modified) Concrete
11.02	Portland Cement
11.03	Mixing Water
11.04	Fine Aggregate for 47-B (Modified) Concrete
11.05	Coarse Aggregate for 47-B (Modified) Concrete
11.06	Aggregate for ABX (Modified) Concrete
11.07	Granular Foundation Course
11.08	Joint Filler
11.09	Joint Sealing Material
11.10	Curing Compound
12	CONSTRUCTION METHODS
12.01	Clearing and Grubbing
12.02	Site Preparation
	Revised 1-18-2010
12.03	Subgrade Preparation
12.04	Water Main and Sanitary Sewer Pipe Bedding and Backfill
12.05	Granular Foundation Course
12.06	Surplus Earth
12.07	Adjustment of Manholes
	Revised 1-18-2010
12.08	Adjustment of Storm Sewer Inlets
12.09	Integral Curb
13	CONCRETE CONSTRUCTION
13.01	Forms and Form Setting
13.02	Air Entraining
13.03	Consistency
13.04	Mixing
13.05	Placing and Finishing
13.06	Surface Test
13.07	Headers
13.08	Transverse Construction Joints
13.9	Transverse Expansion Joints
13.10	Transverse Contraction Joints
13.11	Longitudinal Joints
13.12	Curing
13.13	Sealing of Joints
13.14	Protection
13.15	Opening to Traffic
13.16	Acceptance

Section	Description
14	METHOD OF MEASUREMENT AND BASIS OF PAYMENT
14.01	Clearing and Grubbing
14.02	Site Preparation
14.03	Grading, Surplus Earth, Embankment
14.04	Granular Foundation Course
14.05	Manholes
14.06	Storm Sewer Inlets
14.07	Integral Cub
14.08	Concrete Pavement
14.09	Beams
14.10	Headers
14.11	Transverse Expansion and Miscellaneous Joints
14.12	Concrete Test Cylinders
14.13	Testing
14.14	Miscellaneous

**DIVISION II
PORTLAND CEMENT CONCRETE PAVEMENT**

SECTION 10 - SCOPE OF WORK

The work covered by this division of the specifications consists of furnishing all labor, plant, equipment, appliances, and materials and performing all operations necessary to construct and complete concrete pavement and appurtenances in strict accordance with these specifications, the applicable drawings, and subject to the terms and conditions of the contract.

SECTION 11 - MATERIALS

11.01 Cement - 47-B (Modified) and ABX (Modified) Concrete. The specifications for 47-B (Modified) and ABX (Modified) concrete shall be as specified in Section 1002 "Portland Cement Concrete" of the most current State of Nebraska Department of Roads Standard Specifications for Highway Construction with the following exceptions.

1. Paragraph 1 of Section 1002.04 is deleted and the following added:

For 47-B (Modified) concrete no more than 50 lbs. of total water will be added for each 100 lbs. of cement (water to cement ratio not to exceed 0.50). For ABX (Modified) concrete no more than 47 lbs. of total water will be added for each 100 lbs. of cement (water to cement ratio not to exceed 0.47).

Concrete with water to cement ratios greater than specified above will be rejected. If any water is added to the concrete at any time without the permission of the Engineer, the concrete will be rejected.

2. Portland Cement Concrete for pavement shall meet the following requirements:

<u>Class of Concrete</u>	<u>Compressive Strength Requirements in Pounds per Square Inch</u>	
	<u>7 days</u>	<u>28 days</u>
47-B (Modified)	2100	3600
ABX (Modified)	2300	3800

11.02 Portland Cement. Shall be as specified in Section 1004 "Portland Cement" of the most current Nebraska Department of Roads specifications.

11.03 Mixing Water. Shall be as specified in Section 1005 "Water for Concrete" of the most current Nebraska Department of Roads specifications.

11.04 Fine Aggregate for 47-B (Modified) Concrete. Shall be as specified in Section 1033 "Aggregates", Table 1033.02A "Gradation Limits" of the most current Nebraska Department of Roads specifications.

11.05 Coarse Aggregate for 47-B (Modified) Concrete. Shall be as specified in Section 1033 "Aggregates", Table 1033.03A, of the most current Nebraska Department of Roads specifications.

11.06 Aggregate for ABX (Modified) Concrete. Shall be as specified in Section 1033 "Aggregates" of the most current Nebraska Department of Roads specifications with below noted additions.

It shall be the responsibility of the Contractor to submit test results conforming to ASTM C295 that indicate the aggregate to be used in ABX Modified concrete is non-reactive with the alkalis in cement. If the results of this test are not conclusive, then results shall be submitted that conform to ASTM C227 (Mortar Bar) which remove all doubt as to the acceptability of the aggregate for Portland cement concrete.

These results must be submitted prior to any concrete being used from any source of aggregate. New test results must be submitted each time the aggregate comes from a new source or for each 700 cubic yards of concrete poured.

In the event that non-reactive aggregate is not available, the Contractor will not be allowed to use the sand-gravel mix but will be required to use 47-B Modified Portland cement concrete as specified in these specifications under section entitled Cement - 47-B (Modified) and ABX (Modified) Concrete.

11.07 Granular Foundation Course. The granular materials shall be sand from local pits that are shown on the plans, or it may be a coarse sand, fine sand, loamy soil, or any mixture of any of these materials that conforms to the following requirements:

	<u>Minimum</u>	<u>Maximum</u>
Total Percent Retained on #200 Sieve	80	92
Plasticity Index		6

11.08 Joint Filler. Joint filler shall consist of premoulded bituminous fiber uniformly impregnated with between 35% and 50% durable asphalt by weight and be furnished in strips of the dimensions specified in the plans. A one (1) inch thick sample when compressed to 50% of original thickness at rate of 1/10 inch per minute and released shall show at least 70% recovery within one hour after compression and shall not have required more than 500 pounds per square inch compression load and extrusion of not more than 1/8 inch.

11.09 Joint Sealing Material. The hot pour joint material shall be of the rubber-asphalt type and shall be melted in a double jacket kettle equipped with an agitator for stirring the material during melting and pouring. The rubber-asphalt shall meet Federal Specification SS-S-164 or subsequent revisions.

11.10 Curing Compound. The curing compound shall consist of a nonbituminous pigmented liquid conforming to AASHTO Designation M148-49 or subsequent revisions.

SECTION 12 - CONSTRUCTION METHODS

12.01 Clearing and Grubbing. Except for trees, shrubs, and grasses which are to be preserved as indicated on the plans or as designated by the Engineer, all trees, stumps, hedges, shrubs, weeds, grass, other herbaceous vegetation, and rubbish shall be removed from the right-of-way and from borrow pits furnished by the contracting authority. This work shall be classified as follows:

Clearing shall consist of the cutting, removal, and disposal of trees six (6) inches or more in diameter.

Grubbing shall consist of the removal and disposal of stumps, including roots.

Hedge removal shall consist of the pulling or grubbing and disposal of hedges or other shrubs planted close together in rows. If any individual tree of those composing a hedge has a diameter greater than four (4) inches, it shall be measured separately as a tree.

Weed and rubbish removal shall consist of the removal and disposal of all weeds, grass, other herbaceous vegetation, and all rubbish encountered on the work.

12.02 Site Preparation. This work shall consist of removal and disposal of all crosswalks, private walks, driveway approaches, curbs, curb and gutter, and headers as indicated on the plans or as directed by the Engineer.

Topsoil shall be carefully removed and deposited in storage piles convenient to the area which will subsequently receive topsoil. Topsoil shall be kept separate from other excavated materials and shall be piled free from roots, stones, and other undesirable materials.

The backfill over all existing utility lines shall be consolidated when shown on the plans or directed by the Engineer. This shall be done by water jetting and vibration to the full depth of the utility lines unless other methods are approved by the Engineer. When compaction over existing utility lines is not shown on the plans or is not a bid item and is directed to be done by the Engineer, the work shall be negotiated for in writing before any work is commenced and will be paid for as a single unit.

All sanitary and storm sewers will be televised before a street is paved or repaved to insure that the street will not have to be torn up to repair the sewer in the near future.

Revised 1-18-2010

12.03 Subgrade Preparation. All paving subgrade shall be brought to the exact lines, grades, and cross sections shown on the plans or as directed by the Engineer.

The subgrade shall be constructed to have a uniform density throughout its entire width. All soft or yielding material and other portions of the subgrade which will not compact readily shall be removed as directed. All hollow places, settlements, or other imperfections shall be filled with approved material and compacted.

In all places where embankment may be required to bring the subgrade to the required height, it shall be constructed in horizontal layers not to exceed six (6) inches in depth before rolling. Each successive layer of material placed as described shall be wetted to within 3% of the optimum moisture content and compacted to at least 95% of the maximum dry density obtained at optimum moisture content as determined by AASHTO Method T99.

In all embankment areas where highly expansive soils are encountered, materials shall be wetted at one percent (1%) to three percent (3%) above optimum moisture.

In cuts when the undisturbed earth is suitable for the subgrade, manipulation other than rolling will not be required, provided the upper three (3) inches is at 95% maximum dry density as called for in embankments.

12.04 Water Main, Storm and Sanitary Sewer Pipe Bedding and Backfill. The pipe bedding and backfill shall be Type "C" as required by Division V, Pipe Bedding, Trench Backfill, and Nonshrinkable Backfill. The completion of the trench backfill under pavement shall be adequate to provide 95% of maximum dry density and shall be wetted to within 3% optimum moisture as specified in this division under Subgrade Preparation.

12.05 Granular Foundation Course. This work shall consist of the construction of a compacted foundation course of granular material to the lines, grade, and dimensions shown on the plans on a previously prepared and approved subgrade.

12.06 Surplus Earth. All surplus earth shall be stockpiled by the Contractor at the location or locations designated on the plans or as the Engineer shall direct.

12.07 Adjustment of Manholes. All manholes encountered whether shown on the plans or not shall be brought to the proper grade by removing the castings and adjusting the tops of the existing manholes by removal or addition of concrete or brick, as the case may be, and resetting the frames and covers.

Brick masonry shall consist of the type of brick satisfactory to the Engineer, laid in 1:2 cement mortar. All brick must be wetted before being laid. All joints shall be completely filled with mortar and shall not be less than 1/4 inch and not more than 1/2 inch in thickness.

Contractors are instructed to use plastic or concrete risers to bring manhole ring and covers to grade. Using pieces of wood, concrete or bricks and then filling with concrete mortar will no longer be accepted.

All manholes will be inspected before and after a concrete or asphalt street is laid down to insure that no foreign material is in the flow line or at the bottom of a manhole.

Revised 1-18-2010

12.08 Adjustment of Storm Sewer Inlets. All storm sewer inlets shall be adjusted to line and grade by removing the castings and adjusting the tops of the existing storm sewer inlets by removing or adding concrete or bricks, as the case may be, and resetting the castings.

Brick masonry shall consist of the type of brick satisfactory to the Engineer, laid in 1:2 cement mortar. All brick must be wetted before being laid. All joints shall be completely filled with mortar and shall not be less than 1/4 inch and not more than 1/2 inch in thickness.

12.09 Integral Curb. Integral curb shall be constructed on the edge of the concrete slab in accordance with the plans and typical cross section. This curb shall be placed immediately after the concrete on the pavement has been placed and finished and before it takes its initial set. That part of the pavement which is to be covered by the integral curb shall be cleaned of all laitance and shall be roughened. Integral Curb will be required on all new pavement construction. If construction is a very short section, the Director of Public Works may allow an exception upon written request.

SECTION 13 - CONCRETE CONSTRUCTION

13.01 Forms and Form Setting. On all new mainline pavement construction, slip form process will be required. If the Contractor wants to use standard forms rather than slip forms because the area is small, they must submit a written request to the Director of Public Works for an exception. If the request is granted, the contractor will be required to meet certain requirements as listed herein. Outside forms shall be metal, of depth equal to the design thickness of the pavement at its edge, and straight and free from warp. When integral curb is required, the additional height represented by the curb may be obtained by bolting extra forms upon the top of the main form. Wood forms or flexible or curved metal forms of proper radii shall be used for curves having radii of less than 100 feet. The forms shall be neatly, tightly, and securely pinned and staked to the line and grade furnished by the Engineer. They shall not at any time show a variation of more than 1/8 inch in a ten (10) foot length from the true plane of top of forms. Shimming with loose earth, pebbles, etc. will not be permitted.

Forms shall be cleaned and oiled before concrete is placed against them.

When pavement is being laid contiguous to previously finished concrete pavement of the same finish grade elevation or contiguous to previously finished independent curb and gutter, such finished pavement or curb and gutter may be made to serve as side forms and as a guide for striking, tamping, and finishing equipment.

13.02 Air Entraining. When using specifications for State of Nebraska 47-B concrete, the total air content shall be 6% plus or minus 1-1/2% by volume of the wet concrete as determined by AASHTO Standard Method T-121 or ASTM Method C-231 and up to 9% for sand and gravel mix.

13.03 Consistency. The quantity of water shall be determined by the Engineer in accordance with these specifications under section entitled Cement - 47-B (Modified) and ABX (Modified) Concrete and not varied without the Engineer's consent. The Contractor shall furnish and use with the mixer an approved adjustable water measuring device which will prevent excess water flowing into the mixer so the consistency may be under positive control and all batches may be of the same consistency.

In general, the minimum amount of water shall be used which will produce the required workability. The mortar shall cling to the coarse aggregate and shall show no free water when removed from the mixer. The upper surface of the set concrete shall show a cement film upon the surface and shall be free from all laitance. In no case shall an amount of water be used sufficient to cause the collection of a surplus on the surface or to cause segregation during the transportation to place of deposit. The concrete must be of workable consistency when placed.

13.04 Mixing. The mixing shall be done in a batch-mixer of approved type which will insure the uniform distribution of the material throughout the mass so the mixture is uniform in color and smooth in appearance. No mixer which has a capacity of less than one-sack batch shall be used on any work. The concrete shall be mixed in quantities required for immediate use. Concrete which has developed initial set or is not in place within thirty (30) minutes after the water has been added shall not be used. Retempering concrete by adding water or by other means will not be permitted.

The concrete shall be mixed for a period of at least one (1) minute after all the ingredients are assembled in the drum with the drum revolving at a rate for which the mixer was designed but, in no case, shall it be less than twelve (12) nor more than twenty (20) revolutions per minute. The mixer shall be equipped with an attachment for satisfactorily locking the discharging device to prevent the emptying before the minimum time required. The entire contents of the drum shall be discharged before any materials for the succeeding batch are placed therein.

No concrete shall be mixed while the air temperature is at or below 40 degrees Fahrenheit, except when specifically permitted by the Engineer. In such case, all water used for mixing concrete shall be heated to a temperature of at least 70 degrees but not over 150 degrees Fahrenheit. When artificial heat is applied and the air temperature is above 32 degrees Fahrenheit, the mixed concrete shall not be less than 70 degrees Fahrenheit at the time of the placing in the forms, and no concrete shall be placed in the forms when the air temperature is below 32 degrees Fahrenheit. In no case shall material containing frost or lumps of hardened material be used. When ready-mixed concrete is to be produced, the Contractor shall notify the Engineer in writing at least fourteen (14) days in advance of mixing operations as to location, type of plant and equipment which they propose to use in proportioning, mixing, and hauling concrete.

The Contractor shall furnish at least eight (8) standard 50 pound weights for calibrating and testing scales used in weighing aggregates and cement.

Ready-mixed concrete shall be mixed and delivered to the site of work by means of one of the following combinations of operations:

1. Mixed completely at a central mixing plant and the mixed concrete transported to the point of delivery in a truck agitator or in a truck mixer operating at agitator speed or in approved non-agitating equipment (known as central-mixed concrete).
2. Mixed partially at a central mixing plant and mixing completed in a truck mixer (known as transit-mixed concrete).
3. Aggregates and cement proportioned in a central plant and mixed completely in a truck mixer (known as transit-mixed concrete).

All mixers and agitators shall be operated within the limits of the manufacturer's rated capacity. They shall be operated at the speed of rotation for which the equipment was designed. Attached to each truck mixer and truck agitator shall be a metal plate on which is stated the manufacturer's capacities in terms of volume of mixed concrete and the manufacturer's stated speed of rotation for both mixing and agitation.

The truck mixer or agitator shall consist of a closed water-tight revolving drum suitably mounted and fitted with adequate revolving blades. Truck mixers shall be capable of combining aggregates, cement, and water into a thoroughly mixed and uniform mass of concrete and of discharging the concrete without segregation. Truck agitators shall be capable of transporting and discharging concrete without segregation.

For revolving drum type mixers the mixing speed shall not be less than seven (7) revolutions per minute of the drum nor greater than that which will produce a peripheral velocity of more than 225 feet per minute. For revolving blade type mixers, the mixer speed shall not be less than six (6) nor more than sixteen (16) revolutions per minute of the mixing blades. Agitation speed shall not be less than two (2) nor more than six (6) revolutions per minute of the drum or mixing blades.

Concrete transported without agitation shall not be used if the period elapsed between the time the concrete is discharged from the mixer and the time it is placed is greater than thirty (30) minutes. Concrete transported with agitation shall not be used when the cement has been in contact with the aggregate more than 1-1/2 hours before it is placed.

13.05 Placing and Finishing. The concrete shall be deposited on the prepared subgrade or on the granular foundation course so there shall be no separation of the mortar and the aggregate, and then shall be spread to the required depth and for the entire width of the pavement by approved methods, struck off, and finished. The subgrade templet shall be drawn over the subgrade or foundation course ahead of the point where concrete is being placed and shall be kept in position while the concrete is being placed. The concrete shall be deposited on the subgrade or granular foundation course between the forms in position and in such quantity as to make a uniform layer of about one (1) inch greater than the required thickness. During the operation of striking off the concrete, a uniform ridge of concrete at least three (3) inches in depth shall be maintained ahead of the vibratory strike-off screed for its entire length. After being deposited, it shall be consolidated along the forms and along all joints. At the end of the day or in case of unavoidable interruption of more than thirty (30) minutes, a transverse construction joint shall be placed at the point of stopping work, provided the section on which the work has been suspended shall not be less than ten (10) feet in length. The working edge of the screed shall be shaped to the required cross section of the pavement. After the concrete has been properly consolidated and struck off, the entire surface shall be floated longitudinally, from bridges, with a float at least twelve (12) feet long and twelve (12) inches wide. If made of wood, this float shall be two (2) inches thick. If made of metal, it shall have a weight approximately equal to a similar float made of two (2) inch plank and shall be lined on its bottom face with wood, having rounded edges. The float shall be operated by two men, one at each end, each man standing on a bridge spanning the pavement. The longitudinal and transverse motion shall be passed slowly from one side of the pavement to the other a sufficient number of times, at least twice, until the float on its last passage shall show contact with the concrete throughout its entire length. The bottom surface of the float shall remain flat on the surface of the concrete during the entire operation of longitudinal floating. The next section to be floated shall overlap the one previously floated by half the length of the float.

After the concrete has been floated longitudinally, the surface shall be floated transversely using a float of 1"x12" material three (3) to four (4) feet in length and fitted with a handle of sufficient length to permit the float to reach just beyond the center line. Any high or low areas exposed as a result of this floating shall be corrected prior to belt finishing.

After the concrete has been floated transversely and the water sheen has disappeared from the surface of the pavement, the final finish shall be given with a canvas or rubber belt, burlap drag or brooming, or any combination of the above as directed by the Engineer.

If belting is selected, it shall be accomplished with a belt of two to four ply having a width of not less than six (6) inches and a length at least two (2) feet greater than the width of the pavement. The belt shall be operated with a combined crosswise and longitudinal motion, care being taken not to work the crown out of the pavement or to permit the edges of the belt to dip into the surface of the concrete.

If a broom finish is selected, it shall be accomplished by drawing a broom across the surface from the center line toward each side with the broom held perpendicular to the surface with only one stroke of the broom on each portion of the surface. (If the pavement is being constructed lane-at-a-time, the broom shall be drawn across the full width of each lane in one operation.) The broom shall be of the push broom type not less than 18" wide made from bass or bassine fiber not more than five (5) inches long and with a handle at least one (1) foot longer than the width of pavement being broomed in one operation. The brooming operations shall be executed so the corrugation will be uniform in appearance and not more than 1/16 inch in depth.

If a burlap drag finish is selected, it shall be accomplished by drawing a wet burlap, carpet, or canvas drag over the surface in a longitudinal direction. The drag shall be at least two (2) feet longer than the width of the slab being placed and shall be wide enough so about three (3) feet will be in contact with the pavement while it is in use. If burlap is used, the drag shall consist of not less than two (2) layers. Drags shall be rinsed or washed as often as necessary to remove hardened particles which would mar the uniform surface that would be obtained with a clean drag.

13.06 Surface Test. Before final finishing and previous to initial set, the surface of the pavement shall be tested under the supervision of the Engineer. All irregularities or undulations not within the tolerance of the following test shall be corrected with fresh concrete and the affected surface brought within the requirement of the test and refinished if necessary. The test shall be made with a transverse testing templet and straightedge at least ten (10) feet long. The templet shall be accurately shaped in conformity with the typical cross section and shall be subject to the approval of the Engineer. The templet shall be used to test the shape of the surface transversely, the straightedge for longitudinal trueness. The straightedge shall be placed parallel to the center line so as to bridge any depressions and touch any high spots. Ordinates exceeding one fourth inch measured from the face of the templet or straightedge when in position at any point shall be eliminated by means of a long-handled wood float.

As soon as the pavement has set sufficiently to permit walking on it and not later than 10:00 a.m. of the day following the placing of the concrete, it shall be thoroughly checked by the inspector with a straightedge. All variations in excess of one fourth inch measured from the surface of the straightedge when it is placed parallel to the center line shall be plainly marked. The Contractor shall at once eliminate such variations by the use of approved grinding tools or carborundum brick and water. The work of grinding or rubbing shall not be performed in such manner or carried to such extremes that the bond of the concrete shall be broken. The use of brush hammer or similar device to remove irregularities after the concrete has taken its final set will not be permitted. All templets, straightedges, and other testing devices shall be furnished by the Contractor.

13.07 Headers. Concrete headers extending to full depth and width of the pavement shall be constructed at locations shown on the plans. They shall be constructed to the dimensions and design called for in the plans.

13.08 Transverse Construction Joints. Whenever concreting is stopped for a period of over thirty (30) minutes, a transverse construction joint shall be formed by finishing the concrete to a bulkhead made of two (2) inch material cut to the exact cross section of the pavement slab, as shown in the plans. When the concreting is resumed, the bulkhead shall be moved taking care not to disturb any concrete placed. The joints shall be constructed perpendicular to both the center line and the surface of the pavement. In no case shall an emergency construction joint be allowed within ten (10) feet after placing a regular expansion or construction joint. If the joint falls within this limit, the concrete shall be removed back to the previously installed joint.

When a construction joint is placed at a location where integral curb is being constructed, a piece of pre-formed joint material one half inch in thickness and conforming to the cross section of the curb shall be placed through the curb at the construction joint. The edges of the concrete shall be rounded to a radius of not more than one fourth inch.

13.9 Transverse Expansion Joints. Expansion joints shall be of a premoulded bituminous fiber type conforming to these specifications under the section entitled Joint Filler.

The joint shall extend entirely through the pavement and the joint filler shall be placed so the top edge will be one half inch below the surface of the finished pavement. No section of the joint material shall be shorter than the width of pavement strip between longitudinal joints. Before the pavement is opened to traffic, this space shall be swept, cleaned, and filled with approved joint sealing material.

The pre-formed expansion joint material shall be held securely by means of a special metal joint holder and removable cap, perpendicular to both the center line and the surface of the pavement. The metal joint holder and cap shall remain in place until after the passage of the concrete spreader. After the concrete has been finished, the metal joint holder and cap shall be removed and the edge of the concrete rounded to a radius of not more than one fourth inch. When integral curb is being constructed, an additional piece of pre-formed material of the same cross section as the curb shall be extended through the curb and to the top surface of the pavement. The joints shall be so installed and finished to insure complete separation of the slabs.

13.10 Transverse Contraction Joints. Transverse contraction joints shall be constructed at intervals of not less than ten (10) feet or more than sixteen (16) feet. The joints shall be true and straight to the center line and surface of the pavement. Variation of more than one half inch in ten (10) feet from a straight line will not be permitted. The joint shall be placed so its junction with the longitudinal joint will be a neat fitting connection. All transverse contraction joints shall be done by the saw cut method. To prevent the development of random cracks, joints at approximately eighty (80) feet intervals shall be sawed the same day as the pour is made. All other transverse contraction joints shall be sawed the following afternoon.

13.11 Longitudinal Joints. Longitudinal contraction joints, when required, shall be in accordance with the requirements for transverse contraction joints.

All sawed longitudinal joints shall be sawed before the concrete has attained an age of seven (7) days and before the pavement is opened to any vehicular traffic.

13.12 Curing. As soon as the concrete has hardened sufficiently to prevent excessive marring of the surface or adherence thereto, the concrete shall be protected with a single covering of burlap, placed and kept saturated for at least twelve (12) hours. As soon as the burlap is removed, the top surface and the edges of the pavement shall be covered with a continuous uniform nonbituminous impervious coating. The curing compound may be applied in either one or two applications in accordance with the directions of the manufacturer. However, if applied in two coatings, the second shall be applied not later than thirty (30) minutes after the first. In no case shall the rate of application be less than one (1) gallon per fifteen (15) square yards of surface area.

The sides of the pavement slab or back side of integral curb shall be covered with the curing compound within thirty (30) minutes after removal of the form.

When wet cotton mats, wet jute felt mats, paper, or any other method than curing compound is to be used for curing, the Contractor shall notify the Engineer in writing at least fourteen (14) days in advance giving the type and specifications of material and method to be used.

When it is expected that during the progress of the work the temperature may fall below 40 degrees Fahrenheit, a sufficient supply of straw, hay, grass, or other material suitable, in the judgment of the Engineer, must be maintained on hand to cover the concrete and to sufficiently protect the surface and edges against freezing until it is at least ten (10) days old. In such case, at the discretion of the Engineer, wetting and spraying may be omitted. Manure shall not be used as a protection for green concrete. Whenever the temperature falls below 40 degrees Fahrenheit, freshly finished concrete shall be protected by frames enclosed by canvas or other type of housing and the temperature of the air surrounding the concrete shall be maintained at not less than 45 degrees Fahrenheit. Sufficient heating apparatus, such as lanterns, suitable stoves, or steam equipment, shall be furnished and maintained by the Contractor. Any concrete showing injury by freezing on uncovering shall be removed and replaced at the expense of the Contractor.

13.13 Sealing of Joints. Joint sealing operations shall not be started until after final curing is completed. All joints which require sealing shall be thoroughly cleaned by a jet of compressed air. Any excess mortar or concrete shall be cut out with chisels. Joints shall be filled only when completely dry. The filler used shall be material as specified in these specifications under the section entitled Joint Sealing Material. The cleaning and filling shall be carefully done with proper equipment and a neat workmanlike joint obtained, free from excess and unsightly filler.

The joint sealing material shall be melted uniformly and with constant stirring in an asphalt kettle of such design that direct flames are not applied to the immediate surfaces of the kettle which are in contact with the joint sealing material. The material shall be furnished or prepared in pieces of such size and shape that the material can be melted readily to the proper pouring consistency. The heating of the material shall be arranged to minimize the length of time during which the temperature of the material exceeds 350 degrees Fahrenheit. In no case shall the temperature exceed the maximum recommended by the manufacturer. The joints shall be filled with the use of a pouring device which is satisfactory to the Engineer. Precautions shall be taken to prevent spilling material on surfaces of the pavement adjacent to the joint.

13.14 Protection. The Contractor shall provide and maintain substantial barricades, warning signs, and flares to provide the public and the construction work adequate protection and keep all traffic off the pavement.

13.15 Opening to Traffic. Before any traffic is permitted on the concrete, all curing and protecting materials other than membrane shall be carefully removed from the finished work and the concrete shall be swept clean. No section of pavement shall be opened to traffic until the concrete has reached a minimum age of fourteen (14) days or compression strength of 3000 psi.

The Contractor's forces may be allowed on the pavement for the purpose of clean up work any time after the concrete has reached a minimum age of seven (7) days.

13.16 Acceptance. The Contractor shall furnish a minimum of two (2) cores at locations designated by the Engineer for each 1000 square yards of pavement placed, and the acceptance of the pavement may be governed by the quality and thickness as shown by the cores. Slabs of pavement which are found to be more than one half inch short of the specified thickness shall be removed and replaced at the Contractor's expense with concrete of specified quality and thickness. If, however, in the opinion of the Engineer, there is no probability of immediate failure of such deficient slabs, they may allow the Contractor the choice of leaving the defective slabs in place and receiving no compensation or payment for the same or of replacing the pavement slab as provided above.

If the average strength of test cores or test cylinders, cured at a temperature within the range of 60 to 80 degrees Fahrenheit, is more than ten percent (10%) below the required strength, the Engineer may elect either to permit such pavement to remain in place and limit the payment for such defective work to a maximum of 90% of the contract unit price or require the Contractor, at Contractor's expense, to remove the pavement area deficient in the specified strength and replace it with pavement of satisfactory quality.

SECTION 14 - METHOD OF MEASUREMENT AND BASIS OF PAYMENT

14.01 Clearing and Grubbing. Clearing and grubbing of trees larger than six (6) inches in diameter will be measured for payment by counting the actual number of trees removed. The diameters of trees will be computed by measuring the circumference and dividing by 3.14. Payment shall be made at the contract unit price per each tree at the diameter or group of diameters shown in the bid.

Stumps will be measured for payment by taking the average diameter at cutoff. Payment shall be made at the contract unit price per each stump at the diameter or group of diameters shown in the bid.

Hedge removal will be measured for payment in lineal feet of a row of hedges.

Weeds, rubbish, and other herbaceous vegetation will not be measured for payment but will be considered as subsidiary to the contract work.

14.02 Site Preparation. Crosswalks and private walks to be removed within the area between construction lines will be measured for payment in square feet in their original position. Driveway approaches will be measured for payment in square yards in their original position.

Existing straight curb and curb and gutter to be removed will be measured for payment by length in lineal feet. Measurements for the straight curb will be made along the front face of the curb. Measurements for curb and gutter will be made along the flow line of the gutter.

Removal of existing pavement headers will be measured for payment by length in lineal feet.

Compaction over all existing utility lines will be measured for payment as a single unit except when in clay soil. In clay soil, excavation, additional materials, and recompaction over utility lines will be paid for as additional excavation.

14.03 Grading, Surplus Earth, Embankment. All grading, removal of surplus earth, and embankment will not be measured for payment but shall be subsidiary to the paving.

14.04 Granular Foundation Course. Granular foundation course will be measured for payment by area in square yards or cubic yards.

14.05 Manholes. Adjusting manholes to grade will be measured for payment as a single unit for each manhole that is adjusted to grade as shown in the plans or as directed by the Engineer.

14.06 Storm Sewer Inlets. Adjusting storm sewer inlets to line and grade will be measured for payment as a single unit.

14.07 Integral Curb. Integral curb will be measured for payment by length in lineal feet. Measurement will be made along the back side of the curb.

14.08 Concrete Pavement. Concrete pavement will be measured for payment by area in square yards. Concrete pavement shall include all joints, curing, sealing, etc. not specifically designated as separate items.

14.09 Beams. Concrete pavement beams will be measured for payment by length in lineal feet.

14.10 Headers. Concrete headers constructed as part of the project will be measured for payment by length in lineal feet.

14.11 Transverse Expansion and Miscellaneous Joints. Transverse expansion joints and all miscellaneous joints using premoulded bituminous fiber will be considered incidental to the paving construction and not as a separate pay item.

14.12 Concrete Test Cylinders. Three (3) concrete test cylinders shall be required for each block of concrete pavement placed or as directed by the Engineer.

14.13 Testing. The Engineer may require testing of coarse and fine aggregates and cement before they are used in the work. If so ordered, the Contractor shall pay the cost thereof.

The testing of cylinders shall be paid for by the Contractor.

14.14 Miscellaneous. Any item listed in the Engineer's Estimate and not covered in the specifications will be measured in the most workmanlike manner for payment according to the designation listed such as cubic yards, square feet, square yards, lineal feet, gallons, each, etc.

DIVISION III

CURB AND GUTTER SIDEWALKS, AND DRIVEWAYS

**DIVISION III
CURB AND GUTTER,
SIDEWALKS AND DRIVEWAYS**

C O N T E N T S

Section	Description
15	SCOPE OF WORK
16	MATERIALS
16.01	Cement
16.02	Sand-Gravel
16.03	Fine Sand and Coarse Aggregate
16.04	Water
16.05	Joint Filter
16.06	Joint Sealing Material
17	CONSTRUCTION METHODS
17.01	Subgrade Preparation
17.02	Forms and Form Setting
17.03	Concrete
17.04	Expansion Joints
17.05	Clean Up
18	CURB AND GUTTER
19	SIDEWALKS
20	DRIVEWAYS
21	METHOD OF MEASUREMENT AND BASIS OF PAYMENT
21.01	Curb and Gutter
21.02	Sidewalks
21.03	Driveways
21.04	Expansion and Miscellaneous Joints
21.05	Acceptance

**DIVISION III
CURB AND GUTTER,
SIDEWALKS AND DRIVEWAYS**

This division is written so that ordinarily the type of construction described is complete, but, where applicable, other divisions are considered a part of these specifications.

SECTION 15 - SCOPE OF WORK

This work shall consist of constructing curb and gutter, sidewalks, and driveways of Portland cement concrete on an approved, prepared subgrade in strict accordance with these specifications and in conformity with the lines, grades, and applicable drawings. All curb and gutter districts constructed shall conform to Division II, Portland Cement Concrete, as well as these specifications.

SECTION 16 - MATERIALS

16.01 Cement - Portland cement shall conform to all requirements of ASTM C-150, Type I, "Specifications for Portland Cement", with subsequent additions and amendments thereto, and also the following general requirements.

Cement shall be stored to provide adequate protection against dampness, and no cement shall be used that has become caked or lumpy. No reclaimed cement shall be used. No cement which has been left in storage more than ninety (90) days after shipment from the mill shall be used unless retested and, if failing to meet the requirements specified, shall be rejected. Normally, cement purchased from local dealers shall be considered satisfactory.

16.02 Sand-Gravel - Sand-gravel for concrete shall be a mixture of sand and gravel composed of clean, hard, durable, uncoated pebbles free from injurious amounts of soft or flaky particles, shale, alkali, organic matter, or other deleterious materials. The following materials shall be considered objectionable and percentage by weight shall not be greater than:

Clay lumps	0.5
Coal and carbonaceous shale	0.5
Unsound chert particles retained on 3/8" sieve	3.0

Gradation requirements for sand-gravel aggregates for concrete are as follows:

	<u>Minimum</u>	<u>Maximum</u>
Total % retained on 1" sieve	--	0
Total % retained on #4 sieve	10	35
Total % retained on #10 sieve	45	65
Total % retained on #20 sieve	65	85
Total % retained on #30 sieve	75	85
Total % retained on #100 sieve	95	100
Total % retained on #200 sieve	97	100

Platte River sand-gravel meeting the above gradation is considered satisfactory.

16.03 Fine Sand and Coarse Aggregate. When 47-B concrete is required, see Division II, Portland Cement Concrete Pavement, for specifications.

16.04 Water. Water used for mixing concrete shall be free from oil, acid, alkali, organic matter, or other deleterious materials. Water from wells or City mains shall be considered satisfactory.

16.05 Joint Filter. Joint filter shall consist of premolded bituminous fiber uniformly impregnated with between 35% and 50% durable asphalt by weight and being furnished in strips of the dimensions specified in the plans. A one (1) inch thick sample when compressed to 50% of original thickness at a rate of 1/10 inch per minute and released shall show at least 70T recovery within one hour after compression and shall not have required more than 500 pounds per square inch compression load and extrusion of not more than 1/8 inch.

Expansion joint material shall be 3/4 inch or more in thickness and shall conform to AASHTO M33-48 (Pre-formed Expansion Joint Filler for Concrete).

16.06 Joint Sealing Material. The hot pour paving joint materials shall be of the rubber-asphalt type and shall be melted in a double jacket kettle equipped with an agitator for stirring the material during melting and pouring. The rubber-asphalt shall meet Federal Specifications SS-S-164 or subsequent revisions.

SECTION 17 - CONSTRUCTION METHODS

17.01 Subgrade Preparation. The subgrade shall be prepared by excavating or filling to the required elevation for bottom of concrete. The subgrade shall be thoroughly tamped or otherwise compacted to insure stability. In fills, the subgrade shall be made at least one foot wider on each side than required by the curb and gutter, sidewalk, or driveway.

Stakes will be set by the City Engineering Division of the Public Works Department for line and grade after a sidewalk permit has been issued by the Public Works Department. The subgrade shall slope toward the street curb on a grade of not less than one-fourth inch per foot.

Where fill is required, it will be laid in six (6) inch layers and thoroughly tamped to the satisfaction of the Engineer. Mushy or spongy material will not be used for fill material. Soft and spongy material will be removed and replaced with suitable backfill material.

Trees that are in the way of the sidewalk will be removed including the stump. Roots of trees that are located outside the sidewalk but extend under the sidewalk shall be cut off at least six (6) inches below the sidewalk.

17.02 Forms and Form Setting. The forms shall be of wood or metal, straight and free from warp, and of sufficient strength to resist springing during the process of depositing concrete against them. All forms shall be securely staked, braced, and held firmly to the required line and grade. All forms shall be thoroughly cleaned and oiled before concrete is placed against them.

Wood forms shall be not less than 1-5/8 inches in thickness except for curvilinear sections where properly braced forms of lesser thickness may be used.

Tolerances of 1/8 to 1/4 inch shall be maintained for form alignment and vertical elevation.

17.03 Concrete. Concrete shall conform to Division II, Portland Cement Concrete Pavement.

Concrete shall be mixed in an approved mixer with sufficient water added to produce a workable mix. In no case shall so much water be used as to cause the collection of a surplus on the surface or to cause segregation during transportation to place of deposit. All materials shall be accurately weighed or measured, and mixing shall continue for a full minute after all materials are in the drum of the mixer. Any concrete which is not in place within thirty (30) minutes after the water has been added shall not be used.

The operation of depositing and compacting concrete shall be conducted so as to form a compact, dense, artificial stone of uniform texture which shall show smooth faces on all exposed surfaces.

Transit-mixed or ready-mixed concrete may be used provided the concrete is placed in the forms before it has developed initial set and shall comply with ASTM C95-58 and the requirements of these specifications. Such concrete must be transported in such a way as to prevent segregation between the aggregates and the cement. Concrete shall develop an ultimate compressive strength of not less than figures shown in Section 11.01 when tested in standard 6" x 12" cylinders at an age of twenty-eight (28) days in accordance with ASTM C39-56T.

Hand mixing of concrete will not be permitted except with specific permission of the City Engineer on very small jobs or in case of emergency.

The concrete surface shall be treated with a liquid treatment for curing such as Tri-Kote or approved equal or burlap cure or plastic covering may be used in the concrete cure. The plastic film used for curing concrete or subgrade insulating material shall be tough, pliable, moisture-proof, and sufficiently durable to retain its moisture-proof properties. The plastic film can be a polyethylene film not less than 0.001 inch thick. Reinforcement materials where required or as shown on the plans and wire mesh shall comply with ASTM A-185 and reinforcing bars where required shall conform to ASTM A-15 or A305.

Air entrained concrete shall be obtained by using air-entrained Portland cement or air-entraining admixtures. Air content of fresh concrete shall measure six (6) to nine (9) percent. Air entrained concrete shall be used for all sidewalks, driveways, and curb and gutter.

The use of high-early strength Portland cement concrete will not be required unless stipulated in the plans and in the Special Provisions on certain contracts.

Concrete shall not be placed when inclement weather prevents good workmanship. Concrete shall not be placed when temperature is below 40 degrees F without specific permission of the Engineer.

The surface shall be wood floated to give a proper roughness to prevent foot slippage for normal foot traffic.

The cross slope shall be 1/4 inch per foot of width of sidewalk.

The sidewalk after pouring shall be protected from foot traffic for twenty-four (24) hours and vehicle traffic for seven (7) days.

17.04 Expansion Joints. Expansion joints shall be placed as indicated on the drawings or at each location where new construction connects with existing construction. Specifically, joints shall be placed where new curb and gutter joins existing curb and gutter, where sidewalks connect to curb and gutter, and at such other locations as the Engineer may direct. On long runs of new construction, joints shall be placed as directed. In no case shall the spacing between expansion joints exceed one hundred (100) feet.

SECTION 18 - CURB AND GUTTER

Concrete curb and gutter shall be constructed to the lines, grades, dimensions and design as called for in the drawings.

There shall be installed every six (6) feet a separator true to the dimensions and cross-section of the combined curb and gutter. This separator shall be removed after the concrete has taken its initial set and the joint properly edged to provide a neat joint. In finishing joints prior to and after removal of separators, extreme care shall be exercised to avoid raising the edge of the joint causing water pockets in the gutter flow line. Separators shall not exceed 1/8 inch in thickness. Immediately following finished operations and before the concrete has taken its final set, the gutter flow line shall be checked with a straightedge not less than ten (10) feet in length and approved by the Engineer.

The maximum deviation from true grade shall not exceed 1/4 inch and any irregularities shall be corrected immediately.

SECTION 19 - SIDEWALKS

Concrete sidewalks shall be constructed to the lines and grades determined by the Engineer. Sidewalks shall have a minimum width of four (4) feet and a depth of four (4) inches and shall be constructed with a side slope of 1/4 inch per foot unless otherwise approved by the Engineer or Engineer's representative. Surfaces shall be marked off in square blocks having an area of not less than sixteen (16) nor more than thirty-six (36) feet. On these lines, the concrete shall be cut through not less than 1/4 inch thickness with a pointed trowel or suitable spading tool and the concrete edged on both sides.

Sidewalks that are being constructed across driveway openings shall have a minimum depth of five (5) inches.

The surface shall be floated with a steel float just enough to produce a smooth surface, free from irregularities. All edges and joints shall be rounded to a radius of 1/4 inch with an approved finishing tool. The surface shall then be brushed with a fine bristle broom or wood float to slightly roughen the surface and remove the finishing tool marks.

SECTION 20 - DRIVEWAYS

Driveway approaches connecting private driveways to City streets shall be constructed with Portland cement concrete except where the private driveway connects to a full depth asphalt street. Where the driveway connects to a full depth asphalt street, asphaltic concrete may be used in construction of the driveway approach.

Driveway approaches shall be constructed to the lines and grade set by the Engineer. The minimum depth of both Portland cement concrete and asphaltic concrete for driveway approaches shall be five (5) inches and, in the event heavy loads are anticipated, the depth shall be increased to handle the expected loads.

SECTION 21 - METHOD OF MEASUREMENT AND BASIS OF PAYMENT

21.01 Curb and Gutter. Combination curb and gutter will be measured for payment by length in linear feet. Measurements will be made along the flow line of the gutter.

21.02 Sidewalks. Sidewalks will be measured for payment by area in square feet.

21.03 Driveways. Driveways as referred to in this paragraph are that portion of existing driveway approaches having to be removed behind the construction lines of pavement due to the driveway approach lying partly within the area between construction lines. Driveways will be measured for payment in area in square yards.

21.04 Expansion and Miscellaneous Joints. Expansion joints and all miscellaneous joints using pre-molded bituminous fiber will be considered incidental to the construction and not as a separate pay item.

21.05 Acceptance. Upon completion of a job, the Engineer shall be notified, and they shall make an inspection of the work. The Contractor will be notified in writing as to the acceptability of the work.

DIVISION V

STORM AND SANITARY SEWER

**DIVISION V
STORM AND SANITARY SEWERS**

C O N T E N T S

SECTION	DESCRIPTION
25	SCOPE OF WORK
26	MATERIALS
26.01	Reinforced Concrete Pipe
26.02	Concrete Pipe Joints
26.03	Vitrified Clay Pipe
26.04	Vitrified Clay Pipe Factory-Fabricated Joints
26.05	Cast Iron Pipe and Fittings
26.06	Cast Iron Pipe Joints
26.07	Portland Cement Concrete
26.08	Reinforcement
26.09	Structural Brick
26.10	Storm Sewer Inlet Frames and Grates
26.11	Manhole Rings and Cover
26.12	Grout
26.13	Manholes
26.14	Core Drilling
26.15	Sulfate Resistance Concrete Specifications
27	CONSTRUCTION METHODS
27.01	Excavation
27.02	Protection of Existing Utilities
27.03	Pipe Laying and Jointing
27.04	Manholes Revised 1-6-2023
27.05	Storm Sewer Inlets
27.06	Pipe Bedding
27.07	Trench Backfill
27.08	Backfilling Under Pavement Revised 6-25-2021
27.09	Nonshrinkable Backfill Revised 6-25-2021
27.10	Stacks
27.11	Separation from Water Mains
27.12	Testing
27.13	Exfiltration and Air Testing
27.14	Television Inspection
27.15	Exposure of Pipe or Manholes
28	DRAINAGE STRUCTURE CONSTRUCTION
28.01	Concrete Work
28.02	Brick Work
28.03	Precast Manhole Sections
28.04	Acceptance
29	METHOD OF MEASUREMENT AND BASIS OF PAYMENT
29.01	Sewer Pipe in Place
29.02	Service Tees Revised 1-31-2023
29.03	Manholes
29.04	Storm Sewer Inlets

DIVISION V STORM AND SANITARY SEWERS

This division is written so that ordinarily the type of construction described is complete but, where applicable, other divisions are considered a part of this specification.

SECTION 25 - SCOPE OF WORK

The work covered by this division of the specifications consists of furnishing all labor, plant, equipment, appliances, and materials and performing all operations necessary to construct and complete storm and sanitary sewers and appurtenances in strict accordance with these specifications, the applicable drawings, and subject to the terms and conditions of the contract.

SECTION 26 - MATERIALS

26.01 Reinforced Concrete Pipe. All reinforced concrete pipe shall meet the requirements and specifications of Reinforced Concrete Culvert, Storm Drain and Sewer Pipe, ASTM C76, Class III, and subsequent revisions, or as otherwise shown in the plans.

26.02 Concrete Pipe Joints.

1. Rubber Joint Filler. Rubber based joint filler shall be used on all concrete pipe joints unless otherwise specified.
2. Gasket Type Joints. When gasket type joints are required, they shall be as follows: Bell and Spigot Pipe Joints, ASTM C361, and subsequent revisions
Tongue and Groove Pipe Joints, ASTM C443, and subsequent revisions.

All new storm sewer piping will be plastic or concrete where possible.

26.03 Vitrified Clay Pipe. All vitrified clay pipe shall meet the requirements and specifications for Extra Strength Clay Sewer Pipe conforming to ASTM C700 or C425 compression joint and subsequent revisions or as otherwise shown on the plans.

26.04 Vitrified Clay Pipe Factory-Fabricated Joints. All vitrified clay pipe shall have O-ring gasket factory-fabricated joints that meet the requirements and specifications for Vitrified Clay Pipe Joints Using Materials Having Resilient Properties, ASTM C700 and subsequent revisions or as otherwise shown on the plans.

26.05 Cast Iron Pipe and Fittings. See Division VI, Water Mains.

26.06 Cast Iron Pipe Joints. See Division VI, Water Mains.

26.07 Portland Cement Concrete. The concrete shall be air-entrained as specified in Division III, Curb and Gutter, Sidewalks, and Driveways, in the section entitled Materials -- Sand-Gravel.

26.08 Reinforcement. The deformed bars that are used in reinforcing shall be Type B, Grade 2.

26.09 Structural Brick. Bricks shall be of the type that are satisfactory to the Engineer and shall be laid in 1:2 cement mortar.

26.10 Storm Sewer Inlet Frames and Grates. The frames and grates shall be of cast iron with tensile strength test not less than Class 25.

26.11 Manhole Rings and Covers. Unless shown otherwise on the plans, the rings and covers for manholes shall be 450 pound cast iron machined rings and covers with tensile strength test not less than Class 25.

All manholes will be inspected when any work is being done around the manhole ring and/or cover.

26.12 Grout. Grout, where required, shall consist of equal parts of sand and cement with sufficient water to produce the proper consistency.

26.13 Manholes. All concrete used in the construction of manholes shall be in accordance with the following Sulfate Resistant Concrete Specifications, Section 26.15, dated March 20, 2002. This shall include all concrete used in the construction of pre-case manholes, manhole bases, and manhole inverts.

26.14 Core Drilling. If a sewer service is installed by core drilling into the public sanitary sewer main, the connection will be televised at the Contractor's expense prior to acceptance by the City.

26.15 Sulfate Resistant Concrete Specifications

March 20, 2002

SUBMITTALS

A. Shop Drawings:

1. Curing compound data
2. Complete data on the concrete mix, including aggregate gradations and admixtures, in accordance with ASTM C94

B. Quality Control Submittals:

1. Manufacturer's application instructions for curing compound.
2. Ready-mix delivery tickets for each truck in accordance with ASTM C94.

QUALITY ASSURANCE

- A. Concrete and Reinforcement: Unless otherwise specified. Meet the requirements of ACI 301 and 318/318R
- B. Precast Reinforced Concrete: Unless otherwise specified. Meet the requirements of ASTM C478
- C. Formwork: Unless otherwise specified, follow the recommendations of ACI 347.
- D. Hot Weather Concreting: Conform to ACI 305R
- E. Cold Weather Concreting: Conform to ACI 306R

ENVIRONMENTAL REQUIREMENTS

- A. Do not place Concrete when the ambient temperature is below 40 degrees F or approaching 40 degrees F and air temperature less than 40 degrees F for the first 7 days, without special protection to keep Concrete above 40 degrees F.
- B. Do not use curing compound where solvents in the curing compounds are prohibited by state or federal air quality laws. Use only water curing methods.

CONCRETE

- A. Ready-mixed meeting ASTM C94, Option A.
- B. Portland Cement: ASTM C595, Type IP containing less than 8 percent tricalcium aluminate.
- C. Admixtures:
 - 1. Air-Entraining; ASTM C260.
 - 2. Water-Reducing; ASTM C494, Type A or D.
 - 3. Superplasticizer: ASTM C494, Type for G.
 - 4. Fly Ash: ASTM C618, Class C or F; not to exceed 25% total pozzolan by weight.
- D. Mix Design:
 - 1. Minimum Allowable 28 day Compressive Field Strength: 4,000 psi when cured and tested in accordance with ASTM C31 and C39.
 - 2. Coarse Aggregate Size: 0.5-inch and smaller, 40% Limestone by volume minimum; State of Nebraska approved source.
 - 3. Water/Cement Ratio: 0.38%.
 - 4. Air Entrainment: Between 5.0 to 7.5%.
 - 5. Water Reducers: Use in all concrete as per manufactures recommended guidelines.
 - 6. Suerplasticizer: Use in all walls. Use in slabs at CONTRACTOR's option.
 - 7. Slump Range: 1 to 4 inches; before addition of Suerplasticizer.
 - 8. Slump Range: 5 to 9 inches; after addition of Suerplasticizer.
- E. Mixing: Minimum 70 and maximum 270 revolutions of mixing drum. Nonagitating equipment is not allowed.

REINFORCING STEEL

- A. Deformed Bars: ASTM A615, Grade 60.

FORMWORK

- A. Form Material
 1. Use hard plastic finished plywood for exposed areas, and new shiplap or plywood for unexposed areas.
 2. Earth cuts may be used for forming footings.

- B. Form Ties:
 1. Fixed conical or spherical type inserts that remain in contact with forming material and allow for dry packing of form ties holes.
 2. Ties shall withstand pressures and limit deflection of forms to acceptable limits.
 3. Wire ties are not acceptable.

- C. Construction:
 1. In accordance with ACI 347.
 2. Make joints tight to prevent escape of mortar and to avoid formation of fins.
 3. Brace as required to prevent distortion during concrete placement.
 4. Brace as required to prevent distortion during concrete placement.
On exposed surfaces locate form ties in uniform pattern or as shown. Construct so ties remain embedded in the wall with no metal within 1 inches of concrete surface when forms, inserts, and tie ends are removed.

- D. Form Removal:
 1. Remove forms with care to prevent scarring and damaging the surface.

PLACING REINFORCING STEEL

- A. Unless otherwise specified, place reinforcing steel in accordance with CRSI Recommended practice for placing Reinforcing Bars.

- B. Splices and Laps:
 1. Top Bars: Horizontal bars placed such that 12 inches of fresh concrete is cast below in single placement.
 2. Horizontal wall bars are considered top bars.
 3. Laptop bars 42 diameters or minimum 24 inches.
 4. Lap all other bars 30 diameters or minimum 18 inches. Tie splices with 18-gauge annealed wire as specified in CRSI Standard.

PLACING CONCRETE

- A. Place concrete in accordance with ACI 301.

- B. Prior to placing concrete, remove water from excavation and debris and foreign material from forms. Check reinforcing steel for proper placement and correct discrepancies.

- C. Before depositing new concrete on old concrete, clean surface using sandblast or bush hammer or other mechanical means to obtain a 1/4-inch rough profile.

- D. Place concrete as soon as possible after leaving mixer, without segregation or loss of ingredients, without splashing forms or steel above, and in layers not over 2 feet deep. Place within 1-1/2 hours after adding cement mix.
- E. 8 feet maximum vertical drop to final placement, when not guided with chutes or other devices to prevent segregation due to impact with reinforcing.

COMPACTION

A. Vibrate concrete as follows:

1. Apply vibrator at points spaced not farther apart than vibrator's effective radius.
2. Apply close enough to forms to vibrate surface effectively but not damage form surfaces.
3. Vibrate until concrete becomes uniformly plastic.
4. Vibrator must penetrate fresh placed concrete and into previous layer of fresh concrete below.

CONSTRUCTION JOINTS

A. Locate as shown or as approved.

FINISHING

A. Floor Slabs and Tops of Walls

1. Screed surface to true level planes.
2. After initial water has been absorbed, float with wood float and trowel with steel trowel to smooth finish free from trowel marks.
3. Do not absorb wet spots with neat cement.

B. Unexposed Slab Surfaces: Screed to true surface, bull float with wood float, and wood trowel to seal surface.

PROTECTION AND CURING

- A. Protect fresh concrete from direct rays of sunlight, drying winds, and wash by rain.
- B. Keep concrete slabs continuously wet for a 7-day period. Intermittent wetting is not acceptable or use curing compound only where approved by ENGINEER. Cure formed surfaces with curing compound applied in accordance with manufacturer's directions as soon as forms are removed and finishing is completed.
- C. Remove and replace concrete damaged by freezing.

FIELD TESTS

A. Evaluation of Concrete Field Strength: In accordance with ACI 318/318R

SECTION 27 - CONSTRUCTION METHODS

27.01 Excavation. The ditch shall be excavated along the lines and to the depth as designated by the Engineer. The Contractor shall furnish, at Contractor's expense, all planks, stakes, spikes, grade boards, and twine that may be required. The Engineer shall have the right to limit the amount of trench that may be opened in advance of the line of work. Should the trench be excavated to a greater depth than that given by the Engineer, the Contractor shall refill to grade, at Contractor's expense, with good, well-tamped material. Trenches, where required, shall be properly sheeted and braced. The bottom of the trench under each pipe shall be shaped to receive the bottom quadrant of the pipe barrel. Bell holes shall be excavated so, after placement, only the barrel of the pipe receives bearing pressure from the trench bottom.

Whenever wet or unstable soil that is incapable of properly supporting the pipe, as determined by the Engineer, is encountered in the trench bottom, such soil shall be removed to the depth and length determined by the Engineer and the trench backfilled to grade with sand, gravel, or other suitable material.

All grading in the vicinity of trench excavation shall be controlled to prevent surface water from flowing into the trench. Any water accumulating in the trench shall be removed by pumping or other approved method. Material excavated from the trench shall be stacked in an orderly manner a sufficient distance back from the edge of the trench to avoid overloading and to prevent slides or cave-ins. Materials unsuitable for backfilling shall be wasted by the Contractor as directed by the Engineer.

A minimum of one foot of topsoil (unless otherwise noted on the plans) shall be removed in any and all areas covered by vegetation. This topsoil shall be stockpiled separately from the material removed from the remainder of the trench. After the pipe is installed and the trench backfilled to an elevation one foot (unless otherwise noted on the plans) below grade, the topsoil shall be replaced and compacted as previously described.

Excavation will not be classified. Whatever material is encountered shall be excavated to the proper grades and, if in any location such material is not sufficient to provide a uniform, even bed for the pipe, the trench shall be excavated at least three (3) inches deeper than the grade at the bottom of the pipe and the space thus excavated shall be refilled with earth or sand and thoroughly compacted.

Trench excavation shall not be paid for separately but shall be considered incidental to the sewer in place.

27.02 Protection of Existing Utilities. The accuracy of location of existing underground utilities as shown on the plans is not guaranteed. It shall be the duty of the Contractor to locate these utilities in advance of excavation and to protect them from damage after uncovering. No house service lines are shown on the plans. The Contractor shall contact the owners of the utilities for assistance in locating these service lines. Any expense incurred by reason of damaged or broken lines shall be the responsibility of the Contractor.

Pipe Laying and Jointing. Pipe shall be protected at all times against impact shocks and free fall. Laying of pipe in finished trenches shall be commenced at the lowest point with the spigot ends on bell-and-spigot pipe and tongue ends on tongue-and-groove pipe pointing in the direction of the flow. Pipe shall be set firmly to line and grade and, preparatory to making pipe joints, all surface of the pipe to be jointed shall be cleaned and dried. Joints shall be made tight to meet requirements of tests specified in the section of these specifications entitled Exfiltration, Infiltration, and Air Testing.

Sewer trenches shall be kept free from water by a method approved by the Engineer. The Contractor shall not pump sewage into a street or pump to a storm sewer unless authorized by the Engineer. Sanitary sewage must be returned to the sanitary sewer by means of pipe and hoses unless it is impossible to do so. In that instance, disposal must be approved by the Engineer.

27.04 Manholes. Manholes shall be constructed as indicated on the plans. Tops shall be fitted with cast iron rings and covers weighing approximately 450 pounds and satisfactory to the Engineer. Manhole steps, where indicated on plans shall be injection molded copolymer polypropylene steel reinforced rod type step. Placement shall be in manholes over three (3) feet in depth, placed on approximately sixteen (16) inch centers. Drop inlet manholes shall be constructed where indicated on the plans.

Manholes of Precast sections conforming to ASTM C478 specifications may be used.

The three (3) types of manhole construction which have been approved are as follows:

- Type 1 – Standard Manhole
- Type 2 – Manhole with ConShield
- Type 3 – Manhole with ConShield and Epoxy Coating

Any substitutes must be approved by the Public Works Director.

Revised 1-6-2023

27.05 Storm Sewer Inlets. Storm sewer inlets shall be of the type as shown on the plans and constructed as per the detailed drawings.

27.06 Pipe Bedding. For Class "C" bedding, the space between the pipe and the side of the excavation up to one (1) foot above the top of the pipe shall be filled with sand or fine earth in layers of not more than six (6) inches thick and carefully tamped to form a solid bedding.

For Class "B" bedding, the trench shall be backfilled with a granular fill of crushed stone or pea gravel to an elevation which is half the diameter of the pipe, and the remaining distance from half the diameter of the pipe to one (1) foot above top of pipe shall be a tamped backfill as specified for Class "C" bedding. The granular fill shall have not less than 95% passing 1/2" and not less than 95% retained on a #4 sieve, shall be placed in not more than six (6) inch layers and compacted by slicing with a shovel.

27.07 Trench Backfill. The area more than one foot over the top of pipe shall be designated as trench backfill. Trenches shall not be backfilled until all required tests are performed and until the system installed conforms to the requirements of the plans and specifications. The trenches shall then be carefully backfilled up to one foot above the top of the pipe as specified in the section entitled Pipe Bedding. The balance of the excavated material shall be consolidated in the following manner. As backfilling proceeds, the entire mass shall be vibrated with a mechanical vibrator, provided, however, in all locations where plastic soils are encountered, the backfill material shall not be placed until the moisture content is low enough to obtain maximum density when tamped into place with mechanical tampers. Materials for tamped backfill and the method of placement and compaction thereof shall be specified for Class "C" pipe bedding. The completion of the trench backfill under pavement shall be done according to the section of these specifications entitled Backfilling Under Pavement.

Trench backfill and compaction testing shall adhere to the following requirements:

- A. Public Right-of-Way: Backfill shall be compacted to at least 95% of the maximum dry density (obtained at optimum moisture content plus or minus 2% for silt or clay with no required moisture content for sand) as determined by AASHTO Method T99. The minimum frequency shall be one test for every 12" compacted lift for an area or length worked, but no more than 300' apart. A minimum of one test shall be taken for every 12" compacted lift for each street crossing regardless of the length.
- B. Public Utility Easement: Backfill shall be compacted to at least 90% of the maximum dry density (obtained at optimum moisture content plus or minus 2% for silt or clay with no required moisture content for sand) as determined by AASHTO Method T99. The frequency shall be the same as that for public right-of-way. A minimum of one test shall be taken for every 12" lift for each easement crossing, regardless of the length.

The Engineer in charge shall be furnished a copy of the density testing results. Information on length or area worked, material identification and description, test thickness such as probe length or sample depth, location of sample, elevation of sample, etc. shall be recorded for each sample.

In unimproved areas such as easements and alleys, the trench or opening may be backfilled with sand which shall be flushed into place with water, provided the top twelve (12) inches of backfill shall be made of the excavated topsoil.

No separate or additional payment will be made for backfill compaction and density testing.

27.08 Backfilling Under Pavement.

Standard backfill methods shall be as specified in the section of these specifications entitled Trench Backfill. When standard backfill methods are used, density tests will be required for each twelve (12) inch lift of compacted material placed and for each 300 lineal feet of trench regardless of the length. Density test results shall be submitted to the Engineer before acceptance of the project by the City. Use of nonshrinkable backfill may be required or may be requested for substitution of standard backfill methods by the Contractor under all street sections, existing or proposed, with the approval of the Director Public Works.

Trenches shall not be backfilled until all required tests are performed and the system conforms to the plans and specifications. The Contractor shall maintain the sewer trench backfill for one (1) year from the date of acceptance of the project by the City.

Revised 6-25-2021

27.09 Nonshrinkable Backfill.

All excavations where a sidewalk, curb, gutter, or paved street has been cut or where new paving (concrete or asphalt) will be placed may be backfilled using nonshrinkable backfill per Section 27.08. The backfill shall be filled to the subgrade of the undisturbed sidewalk, curb, gutter, paving, or earth surface. The nonshrinkable backfill shall be a mixture of sand, gravel, Portland cement, and water (such as State of Nebraska Department of Transportation Standard Specifications for Highway Construction, Section 1003.02) which flows easily around the utility being covered and develops a 28 day compressive strength of from 30 to 200 psi. No nonshrinkable backfill mix designs shall be used without the approval of the Director of Public Works. Fly ash may be approved in the mix if test data are submitted to indicate the above characteristics are met.

27.10 Stacks. Where indicated on the plans or directed by the Engineer, six (6) inch stacks will be furnished and constructed complete with clay stoppers to within ten (10) feet of ground surface or above underground water surface. All stacks will be constructed in accordance with the standard plan entitled Stack Construction Details in Division VIII, Standard Plan Drawings.

A separate stack shall be constructed for each house connection and in no case shall two service connections be connected to the same stack.

27.11 Relation to Water Mains.

Horizontal and Vertical Separation. Sewers shall be laid at least 10 feet horizontally from any existing or proposed water main. The distance shall be measured edge to edge. In cases where it is not practical to maintain a 10 foot separation, the appropriate reviewing agency may allow deviation on a case-by-case basis, if supported by data from the design engineer. Such deviation may allow installation of the sewer closer to a water main, provided that the water main is in a separate trench or on an undisturbed earth shelf located on one side of the sewer and at an elevation so the bottom of the water main is at least 18 inches (460 mm) above the top of the sewer.

If it is impossible to obtain proper horizontal and vertical separation as described above, both the water main and sewer must be constructed of slip-on or mechanical joint pipe complying with public water supply design standards of the agency and be pressure tested to 150 psi (1034 kPa) to assure watertightness before backfilling.

Crossings. Sewers crossing water mains shall be laid to provide a minimum vertical distance of 18 inches (460 mm) between the outside of the water main and the outside of the sewer. This shall be the case where the water main is either above or below the sewer. The crossing shall be arranged so that the sewer joints will be equidistant and as far as possible from the water main joints. Where a water main crosses under a sewer, adequate structural support shall be provided for the sewer to maintain line and grade.

When it is impossible to obtain proper horizontal and vertical separation as stipulated above, one of the following methods must be specified:

- a. The sewer shall be designed and constructed of PVC pipe and equal to water pipe, and shall be pressure tested at 150 psi (1034 kPa) to assure water tightness prior to backfilling.
- b. Either the water main or the sewer line may be encased in a watertight carrier pipe which extends 10 feet (3 m) on both sides of the crossing, measured perpendicular to the water main. The carrier pipe shall be of materials approved by the regulatory agency for use in water main construction.

27.12 Testing. Upon completion of sewer, each pipe line and manhole will be tested as specified by the Engineer in charge. The Contractor shall furnish such tools, hose, and other equipment necessary for making such tests and shall be present during the inspection to note any deficiencies that may exist. Before final acceptance, all sewers shall be clean, shall comply with the specifications and all contract documents, and shall be acceptable to the Engineer and municipal authorities.

27.13 Exfiltration and Air Testing. Both the sewer pipe line and the manholes shall be tested. Manholes shall be exfiltration tested only. Sewer pipe lines shall be air tested only.

The first line between manholes shall be tested before backfilling and before any sewer pipe is installed in the remainder of the work. Thereafter, individual or multiple lines (optional to the Contractor with approval of the Engineer) shall be tested.

Exfiltration Test. This test shall be performed according to stated procedures and under the supervision of the Engineer. The test shall be conducted by blocking off all manhole openings, filling the manhole, and measuring the water level in the manhole for reference. The head above the pipe invert shall be about ten (10) feet. The head shall not exceed twenty-five (25) feet or be less than five (5) feet. The parameters for infiltration are similar. When the ground water level is above the pipe invert, the head shall be measured from ground water elevation. The total exfiltration shall not exceed 100 ~~200~~ gallons per inch of diameter per mile of pipe per day. Manholes shall be considered as sections of 48 inch or 60 inch pipe. The exfiltration test shall be maintained for at least two (2) hours or as long as necessary to locate all leaks, as directed by the Engineer. If the leakage in any reach exceeds the allowable maximum, it shall be retested after the leaks are repaired.

Revised 5-20-2021

Air Test. This test shall be performed according to stated procedures and under the supervision of the Engineer.

Equipment used shall meet the following minimum requirements: (a) Pneumatic plugs shall have a sealing length equal to or greater than the diameter of the pipe to be tested, (b) pneumatic plugs shall resist internal testing pressure without requiring external bracing or blocking, (c) all air used shall pass through a single control unit, and (d) individual hoses shall be used for the following connections: (1) from control unit to pneumatic plugs for inflation, (2) from control unit to sealed line for introducing the low pressure air, and (3) from sealed line to control unit for continually monitoring the air pressure inside the pipe being tested.

Procedures: All pneumatic lugs shall be seal tested before being used in the actual test installation. One length of pipe shall be laid on the ground and sealed at both ends with the pneumatic plugs to be checked. Air shall be pressurized to 25 psig. The sealed pipe shall be pressurized to 5 psig. The plugs shall hold against this pressure without movement of the plugs out of the pipe.

After a manhole to manhole reach of pipe has been backfilled and cleaned and the pneumatic plugs are checked by the above procedures, the plugs shall be placed in the line at each manhole and inflated to 25 psig. Low pressure air shall be introduced into this sealed line until the internal air pressure reaches 4 psig greater than the average back pressure of any ground water that may be over the pipe.

After a manhole to manhole reach of pipe has been backfilled and cleaned and the pneumatic plugs are checked by the above procedures, the plugs shall be placed in the line at each manhole and inflated to 25 psig. Low pressure air shall be introduced into this sealed line until the internal air pressure reaches 4 psig greater than the average back pressure of any ground water that may be over the pipe.

At least two (2) minutes shall be allowed for the air pressure to stabilize.

After the stabilization period (3.5 psig minimum pressure in the pipe), the air hose from the control unit to the air supply shall be disconnected. The portion of line being tested shall be termed "acceptable" if the time required in minutes for the pressure to decrease from 3.5 to 3.0 psig (greater than the average back pressure of any ground water that may be over the pipe) shall not be less than the time shown for the given diameters in the following table:

				SPECIFICATION TIME FOR LENGTH (L) SHOWN (MIN:SEC)								
1 Pipe Diameter (in.)	2 Minimum Time (Min: sec)	3 Length for Minimum Time (ft)	4 Time for Longer Length (sec)	100 FT	150 FT	200 FT	250 FT	300 FT	350 FT	400 FT	450 FT	
4	1:53	597	.190L	1:53	1:53	1:53	1:53	1:53	1:53	1:53	1:53	
6	2:50	398	.427L	2:50	2:50	2:50	2:50	2:50	2:50	2:51	3:12	
8	3:47	298	.760L	3:47	3:47	3:47	3:47	3:48	4:26	5:04	5:42	
10	4:43	239	1.187L	4:43	4:43	4:43	4:57	5:56	6:55	7:54	8:54	
12	5:40	199	1.709L	5:40	5:40	5:42	7:08	8:33	9:58	11:24	12:50	
15	7:05	159	2.671L	7:05	7:05	8:54	11:08	13:21	15:35	17:48	20:02	
18	8:30	133	3.846L	8:30	9:37	12:49	16:01	19:14	22:26	25:38	28:51	
21	9:55	114	5.235L	9:55	13:05	17:27	21:49	26:11	30:32	34:54	39:16	
24	11:20	99	6.837L	11:24	17:57	22:48	28:30	34:11	39:53	45:35	51:17	
27	12:45	88	8.653L	14:25	21:38	28:51	36:40	43:16	50:30	57:42	64:89	
30	14:10	80	10.683L	17:28	26:43	35:37	44:31	53:25	62:19	71:13	80:07	
33	15:35	72	12.926L	21:33	32:19	43:56	53:52	64:38	75:24	86:10	96:57	
36	17:00	66	15.384L	25:39	38:28	51:17	64:06	76:55	89:44	102:34	115:23	

In areas where ground water is known to exist, the Contractor shall determine the water elevation prior to running the test. The height of water over the invert of the pipe shall be divided by 2.3 to establish the pounds of pressure that will be added to all readings. For example, if the height of the water is 11-1/2 feet, then the added pressure will be 5 psig. This increases the 3.5 psig to 8.5 psig and the 3.0 psig to 8.0 psig. The allowable drop of one half pound and the timing remain the same. For safety reasons, do not exceed 9.0 psig.

If the installation fails to meet this requirement, the Contractor shall, at Contractor's expense, determine the source of the leakage. Contractor shall then repair or replace all defective materials and/or workmanship. Air testing shall then be performed on the repaired line to meet the above specifications.

27.14 Television Inspection. Television inspection shall be required to determine if any defects exist prior to final acceptance. A minimum of 30 days shall lapse between completion of construction and television inspection.

Mobile closed circuit television inspection equipment shall be used to televise sewer lines between manholes. The camera shall be pulled through the line. Push type cameras are not acceptable. Robotic type camera equipment shall be used to televise stubouts.

The television camera used for the inspection shall be a color camera specifically designed and constructed for such inspection. Lighting for the camera shall be suitable to allow a clear picture for the entire periphery of the pipe. Picture quality and definition shall be satisfactory to the Engineer. Inspection operations shall cease if the quality of the image on the screen is unsatisfactory. No payment will be made for unsatisfactory inspections.

A continuous image for viewing shall be produced. The images shall be of first rate quality according to the currently accepted standards for television inspection of sewers. A system, which displays the camera location in feet on the monitor with respect to the starting manhole's centerline, shall be used. This system shall automatically update the camera location display as the camera is pulled forward or backward through the sewer line.

Measurement for location of observations to be recorded shall be made at the ground level by means of a meter device. Measurement meters shall be accurate to one-half (0.5) foot. Measurements shall be referenced from the center of the manhole where the camera is started to the center of the manhole where observations are terminated. The measurements shall be checked at the completion of the observations by measuring the distance between manhole centers at the ground level. The observed measurements made by the meter and the ground level measurements shall correspond to within plus or minus one foot. Surface measurements shall be made by the contractor in the presence of the Engineer's representative.

The television camera shall be moved through the line at a uniform slow rate. During the inspection the camera shall be stopped at the points where one or more of the following conditions are observed and distances recorded.

1. Service line tees, wyes or taps.
2. Infiltration/inflow sources.
3. Structural defects, including broken pipe, collapsed pipe, cracks, punctures, settling, etc.
4. Abnormal joint conditions, such as horizontal and vertical misalignment, open joints, joints not fully sealed, etc.
5. Unusual conditions.

All such conditions shall be photographed as determined by the Engineer. Photographs of all questionable conditions shall be taken for subsequent review. The photographs shall be taken from the image on the TV monitor with a Polaroid, a 35 mm camera, or other approved methods. Before taking the photographs, the TV camera shall be properly positioned so the optimum view can be obtained. The image size of photographs shall be no smaller than three inches by four inches.

All photographs shall be identified by location, date taken, and names of the owner's and Contractor's representative. The location of all photographs shall be identified by recording the distance from each defect or point of interest to the center of the reference manhole. All photographs shall be submitted as specified.

A DVD/CD with a clear and audible voice narrative of the entire TV monitoring shall be furnished. Each disk will be delivered to the Engineer in charge. Each disk shall be titled on the screen with the date, manhole numbers, pipe size, district or project number. The camera shall be set to begin at the center of the manhole and the footage zeroed out.

The title shall change at each manhole and the footage zeroed out again before starting a new pull when more than one section of sewer is televised in succession. Defects in the sewer line shall be repaired or replaced by the Contractor, as directed by the Engineer, at no cost to the City.

One bound copy of the final inspection report shall be submitted to the Engineer. Included in the report shall be a map showing the work area, a wye location report, a television inspection report, and a DVD/CD and all pictures.

Television inspection shall be measured and paid for on the basis of unit price as set forth in the bid. Such unit price payment shall be full compensation for all reports, photographs, and other work related work to complete the closed circuit television monitoring.

27.15 Exposure of Pipe or Manholes. The Contractor shall conduct the work at all times in such a manner as will insure no disruption to the normal function of the sanitary sewer collection system. Particular attention shall be paid to the threat of introduction of storm water or other waters to the piping and manholes of the collection system. The Contractor shall take whatever precautions are necessary, such as, but not limited to, installation of plugs in exposed pipes and manholes when work is not in progress or when leaving the work site. The Contractor will be held responsible for damages which may occur to either the collection system or to private property through introduction of storm water or other waters to exposed piping or manholes relating to the construction work.

SECTION 28 - DRAINAGE STRUCTURE CONSTRUCTION

28.01 Concrete Work. The construction of forms, mixing, placing, finishing, and curing of concrete work, as well as the fabrication, placement, protection, and cleaning of reinforcement, shall conform to the applicable parts of Division II, Portland Cement Concrete Pavement.

28.02 Brick Work. All brick shall be wetted before being laid in a 1:2 cement mortar. All joints shall be completely filled with mortar and shall not be less than 1/4 inch and not more than 1/2 inch in thickness. The joints shall be completely filled, smooth and free from surplus mortar on the inside of the walls. Bricks shall be laid radially with every sixth course laid as a stretcher course. Brick shall be plastered with 1/2 inch of mortar over the entire outside surface of wall.

28.03 Precast Manhole Sections. Precast concrete sections for manholes shall be installed with bituminous joint filler.

28.04 Acceptance. Upon completion of a job, all debris and surplus materials shall be removed from the job by the Contractor. The Engineer shall be notified, and shall make an inspection of the work. The City will be notified in writing as to the acceptability of the work.

Prior to City acceptance all storm and sanitary sewers will be televised by the City. Payment will be per foot for televising. Fifteen (15) days after any dewatering wells have been turned off the televising can be performed.

Any cleaning performed by the City will be charged by the hour to the Contractor.

SECTION 29 - METHOD OF MEASUREMENT AND BASIS OF PAYMENT

29.01 Sewer Pipe in Place. Sewer pipe shall be measured and paid for at the contract unit price per lineal foot for various sizes including excavation and backfill complete in place. Sewer pipe shall be measured for payment after installation of the sewer through all line manholes and through the walls of structures and existing manholes and shall include the portion of all wyes considered as main line sewer. Such payment shall be full compensation for all labor, plant, equipment, and materials necessary for a complete and acceptable project, including removal of all debris and final cleanup of the job.

29.02 Service Tees. Tees shall be paid for at the contract unit price for various size tees. Measurement for payment shall include that portion of the tee from the barrel of the main line sewer to the end of the tee. A 1" x 4" lumber sufficient in length to reach the ground surface shall be placed vertically at the end of each service lateral, or approved alternate marker.

Revised 1-31-2023

29.03 Manholes. Manholes shall be paid for at the contract unit price bid per manhole for a depth of five (5) feet which payment shall include base, stubouts, and ring cover. Additional payment shall be made for manholes more than five (5) feet in depth, measured from flow line to top of cover, at the contract unit price for each vertical foot or fraction thereof in excess of five (5) feet.

29.04 Storm Sewer Inlets. Storm sewer inlets shall be paid for at the contract unit price bid per inlet.

Please note: This work falls under the Davis-Bacon Act, as amended (40 U.S.C. 276a to a-7) and that contractor shall supply the Community Development Department with certified payroll documentation. The Davis-Bacon and Related Acts will apply to contractors and subcontractors performing construction, alteration, or repair with federally funded or assisted contracts \$2,000 or more. Under this Act, contractors shall be required to pay wages specified in a wage determination made by the Secretary of Labor. In addition, contractors shall be required to pay wages not less than once a week. A current copy of the prevailing wage and supplementary conditions will be attached to this document. The awarded contractor must be in active status on the System of Award Management also known as SAM.gov before entering into a contract with the City of Grand Island for any project that includes the use of Federal funds.

Community Development Block Grant Regulations
BONDING AND INSURANCE REQUIREMENTS
CODE OF FEDERAL REGULATIONS 24CFR85.36

(h) Bonding requirements. For construction or facility improvement contracts or subcontracts exceeding the simplified acquisition threshold*, the awarding agency may accept the bonding policy and requirements of the grantee or sub-grantee provided the awarding agency has made a determination that the awarding agency's interest is adequately protected. If such a determination has not been made, the minimum requirements shall be as follows:

(1) A bid guarantee from each bidder equivalent to five percent of the bid price. The "bid guarantee" shall consist of a firm commitment such as a bid bond, certified check, or other negotiable instrument accompanying a bid as assurance that the bidder will, upon acceptance of his bid, execute such contractual documents as may be required within the time specified.

(2) A performance bond on the part of the contractor for 100 percent of the contract price. A "performance bond" is one executed in connection with a contract to secure fulfillment of all the contractor's obligations under such contract.

(2) A payment bond on the part of the contractor for 100 percent of the contract price. A "payment bond" is one executed in connection with a contract to assure payment as required by law of all persons supplying labor and material in the execution of the work provided for in the contract.

*fixed at 41 U.S.C. 403(11) (currently set at \$100,000)

CIVIL RIGHTS AND EQUAL OPPORTUNITY PROVISIONS

Public Law 88-352, Title VI of the Civil Rights Act of 1964 (42 U.S.C. 2000(d), et. seq.) (24 CFR part 1).

The law provides that, "No person in the United States shall, on the ground of race, color, or national origin, be excluded from participation in, be denied the benefits of, or be subjected to discrimination under any program or activity receiving Federal financial assistance."

Section 109 of the Housing and Community Development Act of 1974, As Amended.

The law requires that, "[n]o person in the United States shall on the ground of race, color, national origin, religion, or sex be excluded from participation in, be denied the benefits of, or be subjected to discrimination under any program or activity funded in

whole or in part with funds made available under this chapter. Any prohibition against discrimination on the basis of age under the Age Discrimination Act of 1975 [42 U.S.C. 6101 et seq.] or with respect to an otherwise qualified handicapped individual as provided in section 794 of Title 29 also shall apply to any such program or activity.“

Age Discrimination Act of 1975, As Amended (42 U.S.C. 6101, Et, seq.).

The law provides that, “no person in the United States shall, on the basis of age, be excluded from participation in, be denied the benefits of, or be subjected to discrimination under, any program or activity receiving Federal financial assistance.“

Section 504 of the Rehabilitation Act of 1973, As Amended (29 U.S.C. 794).

“Section 504 provides that no otherwise qualified individual with a disability shall, solely by reason of his or her disability, be excluded from the participation in, be denied the benefits of, or be subjected to discrimination under any program or activity receiving Federal financial assistance.”

Section 3 of the Housing and Urban Development Act of 1968, As Amended (12 U.S.C. 1701u).

The law provides that, “to the greatest extent feasible, recipients of HUD funds (and their contractors and subcontractors) provide jobs and other economic opportunities to low-income persons, particularly public housing residents. Section 3 helps create employment for low-income persons and contracting opportunities for businesses that are owned by low-income people or that provide employment to low-income people.”

SPECIAL EQUAL OPPORTUNITY PROVISIONS

A. Activities and Contracts Not Subject to Executive Order 11246, As Amended (Applicable to Federally assisted construction contracts and related subcontracts \$10,000 and under)

During the performance of this contract.

(1) The Contractor shall not discriminate against any employee or applicant for employment because of race, color, religion, sex, or national origin. The contractor shall take affirmative action to ensure that applicants for employment are employed, and that employees are treated during employment, without regard to their race, color, religion, or national origin. Such action shall include, but not be limited to: employment upgrade, demotion, or transfer; recruitment or recruitment advertising; layoff or termination; rates of pay, or other forms of compensation; and selection for training, including apprenticeship.

(2) The contractor shall post in conspicuous places, available to employees and applicants for employment, notices to be provided by contracting officer setting forth the provisions of the nondiscrimination clause. The contractor shall state that all qualified applicants will receive consideration for employment without regard to race, color, religion, sex, or national origin.

(3) Contractors shall incorporate foregoing requirements in all subcontracts.

B. Executive Order 11246 (contract/subcontracts above \$10,000)

1. SEC. 202. Except in contracts exempted in accordance with Section 204 of this order, all Government contracting agencies shall include in every government contract hereafter entered into the following:

During the performance of this contract:

(1) The contractor will not discriminate against any employee or applicant for employment because of race, color, religion, sex, or national origin. The contractor will take affirmative action to ensure that applicants are employed, and that employees are treated during employment, without regard to their race, color, religion, sex or national origin. Such action shall include, but not be limited to: employment upgrade, demotion, or transfer; recruitment or recruitment advertising; layoff or termination; rates of pay, or other forms of compensation; and selection for training, including apprenticeship. The contractor agrees to post in conspicuous places, available to employees and applicants for employment, notices to be provided by the contracting officer setting forth the provisions of the nondiscrimination clause.

(2) The contractor will, in all solicitations or advancements for employees placed by or on behalf of the contractor, state that all qualified applicants will receive consideration for employment without regard to race, color, religion, sex or national origin.

(3) The contractor will send to each labor union or representative of workers with which he has a collective bargaining agreement or other contract or understanding, a notice, to be provided by the [Contract Compliance Officer], advising the labor union or workers' representative of the contractor's commitments under Section 202 of Executive Order No. 11246 of September 24, 1965, and shall post copies of the notice in conspicuous places available to employees and applicants for employment.

(4) The contractor will comply with all provisions of Executive Order No. 11246 of Sept. 24, 1965, and the rules, regulations, and relevant orders of the U.S. Secretary of Labor.

(5) The contractor will furnish all information and reports required by Executive Order No. 11246 of September 24, 1965, and by the rules, regulations, and orders of the Secretary of Labor, or pursuant thereto, and will permit access to their books, records, and accounts by the [Department] and the Secretary of Labor for purposes of investigation to ascertain compliance with such rules, regulations, and orders.

(6) In the event of the contractor's noncompliance with the nondiscrimination clauses of this contract, or with any of such rules, regulations, or orders, this contract may be cancelled, terminated, or suspended in whole or in part and the contractor may be declared ineligible for further government contracts in accordance with procedures authorized in Executive Order No. 11246 of Sept. 24, 1965, and such other sanctions may be imposed and remedies invoked as provided in Executive Order No. 11246 of September 24, 1965, or by rule, regulation, or order of the Secretary of

Labor, or as otherwise provided by law.

(7) The contractor will include the provisions of paragraphs (1) through (7) in every subcontract or purchase order unless exempted by rules, regulations, or orders of the Secretary of Labor issued pursuant to Section 204 of Executive Order No. 11246 of September 24, 1965, so that such provisions will be binding upon each subcontractor or vendor.

The contractor *will* take such action with respect to any subcontract or purchase order as may be directed by the [Department and the] Secretary of Labor as a means of enforcing such provisions, including sanctions for noncompliance: Provided, however, that in the event the contractor becomes involved in, or is threatened with, litigation with a subcontractor or vendor as a result of such direction [by the Department], the contractor may request the United States to enter into such litigation to protect the interests of the United States.

ACCESS TO AND MAINTENANCE OF RECORDS

The Consultant/Contractor agrees to maintain such records and follow such procedures as may be required under HUD Community Planning and Development (CPD) subpart J, 570.502 (paragraph a. 16.) and 24CFR85.42 (paragraphs (b) and (c)) and any such procedures that the department may prescribe. In general such records will include information pertaining to the contract, obligations and unobligated balances, assets and liabilities, outlays, equal opportunity, labor standards (as appropriate), and performance. All such records and all other records pertinent to this contract and work undertaken under this contract shall be retained by the Consultant/Contractor or grantee for a period of three years after the final audit of the grantee's CDBG project, unless a longer period is required to resolve audit findings or litigation. In such cases, the grantee shall request a longer period for record retention. The grantee, the department and duly authorized officials of the state and federal government shall have full access and the right to examine any pertinent documents, papers, records and books of the Consultant/Contractor involving transactions to this local program and contract.

Conflict of Interest

From 24CFR85.36, no officer, employee or agent of the Grantee who will participate in the selection, the award, or the administration of this grant, may obtain a personal or financial interest or benefit from the activity or have an interest in any contract, subcontract or agreement with respect thereto, or the proceeds thereunder either for themselves or those with whom they have family or business ties, during their tenure or for one year thereafter. It is further required that this stipulation be included in all subcontracts to this Contract. Upon written request, exceptions may be granted upon a case by case basis when it is determined that such an exception will serve to further the purposes of the Act and the effective and efficient administration of the recipient's program or project. These exceptions are granted by the Department.

CLEAN AIR AND WATER ACTS – REQUIRED CLAUSES

This clause is required in all third-party contracts involving projects subject to the Clean Air Act (42 U.S.C. s/s 7401 et seq. (1970)), the Federal Water Pollution Control Act (33

U.S.C. 1251 et. seq.), and the regulation of the Environmental Protection Agency with respect to 40 CFR32 as amended. It also should be mentioned in the bid document. During the performance of this contract:

(1) The CONTRACTOR will certify that any facility to be utilized in the performance of any nonexempt contract or subcontract is not listed on the List of Violating Facilities issued by the Environmental Protection Agency pursuant to 48 CFR 9.40 and 40CFR32.20.

(2) The CONTRACTOR agrees to comply with all the requirements of Section 114 of the Clean Air Act, as amended, (42 U.S.C. 7414) and Section 308 of the Clean Water Act, as amended (33 U.S.C. 1318) relating to inspection, monitoring, entry, reports, and information, as well as all other requirements specified in said Section 114 and Section 308, and all regulations and guidelines issued thereunder.

(3) The CONTRACTOR agrees that as a condition for the award of the contract, prompt notice will be given of any notification received from the Director, Office of Federal Activities, and Environmental Protection Agency, indicating that a facility utilized, or to be utilized for the contract is under consideration to be listed on the Environmental Protection Agency List of Violating Facilities.

(4) The CONTRACTOR agrees that it will include or cause to be included the criteria and requirements in Paragraphs (1) through (4) of this section in every nonexempt subcontract and require every subcontractor to take such action as the government may direct as a means of enforcing such provisions.

"General Decision Number: NE20230031 01/06/2023

Superseded General Decision Number: NE20220031

State: Nebraska

Construction Type: Highway

Counties: Adams, Blaine, Buffalo, Clay, Custer, Franklin, Garfield, Greeley, Hall, Hamilton, Harlan, Howard, Kearney, Loup, Merrick, Nance, Nuckolls, Phelps, Sherman, Valley, Webster and Wheeler Counties in Nebraska.

HIGHWAY CONSTRUCTION PROJECTS

Note: Contracts subject to the Davis-Bacon Act are generally required to pay at least the applicable minimum wage rate required under Executive Order 14026 or Executive Order 13658. Please note that these Executive Orders apply to covered contracts entered into by the federal government that are subject to the Davis-Bacon Act itself, but do not apply to contracts subject only to the Davis-Bacon Related Acts, including those set forth at 29 CFR 5.1(a)(2)-(60).

If the contract is entered into on or after January 30, 2022, or the contract is renewed or extended (e.g., an option is exercised) on or after January 30, 2022:	. Executive Order 14026 generally applies to the contract. The contractor must pay all covered workers at least \$16.20 per hour (or the applicable wage rate listed on this wage determination, if it is higher) for all hours spent performing on the contract in 2023.
---	---

If the contract was awarded on or between January 1, 2015 and January 29, 2022, and the contract is not renewed or extended on or after January 30, 2022:	. Executive Order 13658 generally applies to the contract. The contractor must pay all covered workers at least \$12.15 per hour (or the applicable wage rate listed on this wage determination, if it is higher) for all hours spent performing on that contract in 2023.
---	--

The applicable Executive Order minimum wage rate will be

adjusted annually. If this contract is covered by one of the Executive Orders and a classification considered necessary for performance of work on the contract does not appear on this wage determination, the contractor must still submit a conformance request.

Additional information on contractor requirements and worker protections under the Executive Orders is available at <http://www.dol.gov/whd/govcontracts>.

Modification Number Publication Date
0 01/06/2023

ENGI0571-005 01/01/2013

	Rates	Fringes
OPERATOR: Trencher.....	\$ 20.83	9.60

SUNE2011-027 08/29/2011

	Rates	Fringes
CARPENTER.....	\$ 17.16	

CEMENT MASON/CONCRETE FINISHER

Adams, Blaine, Buffalo,
Clay, Franklin, Garfield,
Greeley, Hall, Hamilton,
Harlan, Howard, Kearney,
Loup, Merrick, Nance,
Nuckolls, Phelps, Sherman,
Valley Webster, WHEELER
Counties.....\$ 14.06 **
Custer County.....\$ 15.38 **

ELECTRICIAN, Includes
Installation of Traffic
Signals.....\$ 19.00

FENCE ERECTOR.....\$ 12.83 **

HIGHWAY/PARKING LOT STRIPING:

Laborer
Adams, Blaine, Buffalo,
Custer, Clay, Franklin,
Garfield, Greeley, Hall,
Hamilton, Harlan, Howard,
Loup, Merrick, Nance,
Nuckolls, Phelps, Sherman,
Valley Webster, & WHEELER
Counties.....\$ 11.49 **
Kearney County.....\$ 12.00 **

IRONWORKER, REINFORCING.....\$ 17.93

LABORER: Common or General

Adams County.....\$ 11.52 **
Blaine, Clay, Franklin,
Garfield, Greeley, Howard,
Kearney, Loup, Merrick,
Nance, Phelps, Sherman,
Webster & Wheeler Counties..\$ 11.39 **
Buffalo County.....\$ 9.43 **
Custer County.....\$ 11.12 **
Hall County.....\$ 12.79 **
Hamilton County.....\$ 12.77 **
Harlan County.....\$ 12.24 **
Nuckolls County.....\$ 10.64 **
Valley County.....\$ 11.13 **

LABORER: Landscape &
Irrigation.....\$ 8.30 **

LABORER: Mason Tender -
Cement/Concrete.....\$ 9.75 **

LABORER: Traffic Control -
Flagger and Cone/Barrel Setter
Adams County.....\$ 8.75 **
Blaine, Clay, Custer,
Franklin, Garfield,
Greeley, Loup, Merrick,
Nance, Nuckolls, Phelps,
Webster & Wheeler Counties..\$ 10.16 **
Buffalo County.....\$ 10.97 **
Hall County.....\$ 9.72 **
Hamilton County.....\$ 9.65 **
Harlan County.....\$ 11.96 **
Howard County.....\$ 9.35 **
Kearney County.....\$ 9.68 **
Sherman County.....\$ 9.83 **
Valley County.....\$ 11.15 **

LABORER
Asphalt Raker.....\$ 11.13 **

Operating Engineers: (Skid
Loader).....\$ 12.96 **

OPERATOR: Asphalt Plant.....\$ 12.75 **

OPERATOR: Backhoe Loader
Combo.....\$ 14.33 **

OPERATOR: Broom/Sweeper.....\$ 10.77 **

OPERATOR: Bulldozer.....\$ 15.69 **

OPERATOR: Chain Saw.....\$ 13.35 **

OPERATOR: Compactor.....\$ 10.05 **

OPERATOR: Crane

Adams, Blaine, Buffalo,
Custer, Clay, Franklin,
Garfield, Greeley, Hall,
Hamilton, Howard, Kearney,
Loup, Merrick, Nance,
Nuckolls, Phelps, Sherman,
Valley Webster, & Wheele
Counties.....\$ 16.17 **
Harlan County.....\$ 13.60 ** 1.80

OPERATOR: Distributor.....\$ 14.37 **

OPERATOR: Loader

Adams, Blaine, Clay,
Franklin, Garfield,
Greeley, Hamilton, Howard,
Kearney, Loup, Marrick,
Nance, Nuckolls, Phelps,
Sherman, Valley, Webster,
Wheeler Counties.....\$ 14.68 **
Buffalo County.....\$ 15.21 **
Custer County.....\$ 17.58
Hall County.....\$ 13.78 **
Harlan County.....\$ 13.02 **

OPERATOR: Mechanic

Adams, Blaine, Buffalo,
Custer, Clay, Franklin,
Garfield, Greeley,
Hamilton, Harland, Howard,
Kearney, Loup, Merrick,
Nance, Nuckolls, Phelps,
Sherman, Valley Webster, &
Wheele Counties.....\$ 15.42 **
Hall County.....\$ 16.42

OPERATOR: Paver (Asphalt,
Aggregate, and Concrete).....\$ 12.35 **

OPERATOR: Roller

Adams County.....\$ 12.16 **
Blaine, Buffalo, Custer,
Clay, Franklin, Garfield,
Greeley, Hall, Hamilton,
Howard, Kearney, Loup,
Merrick, Nance, Nuckolls,
Phelps, Sherman, Webster,

& WHEELER COUNTIES.....\$ 12.00 **
Harlan County.....\$ 12.86 **
Valley County.....\$ 12.30 **

OPERATOR: Scraper

Adams, Blaine, Buffalo,
Custer, Clay, Franklin,
Garfield, Greeley, Hall,
Hamilton, Howard, Kearney,
Loup, Merrick, Nance,
Nuckolls, Phelps, Sherman,
Valley Webster, & Wheeler
Counties.....\$ 15.79 **
Harlan County.....\$ 15.50 **

OPERATOR: Screed.....\$ 12.01 **

OPERATOR: Tractor

Adams, Blaine, Buffalo,
Custer, Clay, Franklin,
Garfield, Greeley,
Hamilton, Harland, Howard,
Kearney, Loup, Merrick,
Nance, Nuckolls, Phelps,
Sherman, Valley Webster, &
Wheeler Counties.....\$ 12.80 **
Hall County.....\$ 13.73 **

OPERATOR: Grader/Blade

Adams County.....\$ 18.25
Blaine, Buffalo, Custer,
Clay, Franklin, Garfield,
Greeley, Hamilton, Howard,
Kearney, Loup, Merrick,
Nance, Nuckolls, Phelps,
Sherman, Webster & Wheeler
Counties.....\$ 15.51 **
Hall County.....\$ 15.85 **
Harlan County.....\$ 14.49 **
Valley County.....\$ 15.48 **

POWER EQUIPMENT OPERATOR:
(BACKHOE, EXCAVATOR, TRACKHOE)

Adams, Blaine, Buffalo,
Clay, Custer, Franklin,
Garfield, Greeley, Hall,
Hamilton, Howard, Kearney,
Loup, Merrick, Nance,
Nuckolls, Phelps, Sherman,
Valley, Webster, Wheeler....\$ 15.14 **
Harlan.....\$ 14.36 ** 1.71

TRUCK DRIVER (LOWBOY)

Adams, Blaine, Buffalo,

Custer, Clay, Franklin,
Garfield, Greeley,
Harland, Howard, Kearney,
Loup, Merrick, Nance,
Nuckolls, Phelps, Sherman,
Valley Webster, & WHEELER
Counties.....\$ 11.99 **
Hall County.....\$ 13.20 **
Hamilton County.....\$ 13.50 **

TRUCK DRIVER, Includes Dump
and Tandem Truck

Adams County.....\$ 12.13 **
Blaine, Buffalo, Custer,
Clay, Franklin, Garfield,
Greeley, Harland, Kearney,
Loup, Merrick, Nance,
Nuckolls, Phelps, Sherman,
Valley Webster, & Wheeler
Counties.....\$ 12.18 **
Hall & Howard Counties.....\$ 11.00 **
Hamilton County.....\$ 13.58 **

TRUCK DRIVER: Oil
Distributor Truck.....\$ 13.25 **

TRUCK DRIVER: Semi-Trailer
Truck.....\$ 11.25 **

TRUCK DRIVER: Water Truck.....\$ 11.00 **

WELDERS - Receive rate prescribed for craft performing
operation to which welding is incidental.

=====

** Workers in this classification may be entitled to a higher
minimum wage under Executive Order 14026 (\$16.20) or 13658
(\$12.15). Please see the Note at the top of the wage
determination for more information.

Note: Executive Order (EO) 13706, Establishing Paid Sick Leave
for Federal Contractors applies to all contracts subject to the
Davis-Bacon Act for which the contract is awarded (and any
solicitation was issued) on or after January 1, 2017. If this
contract is covered by the EO, the contractor must provide
employees with 1 hour of paid sick leave for every 30 hours
they work, up to 56 hours of paid sick leave each year.
Employees must be permitted to use paid sick leave for their
own illness, injury or other health-related needs, including
preventive care; to assist a family member (or person who is
like family to the employee) who is ill, injured, or has other
health-related needs, including preventive care; or for reasons

resulting from, or to assist a family member (or person who is like family to the employee) who is a victim of, domestic violence, sexual assault, or stalking. Additional information on contractor requirements and worker protections under the EO is available at <https://www.dol.gov/agencies/whd/government-contracts>.

Unlisted classifications needed for work not included within the scope of the classifications listed may be added after award only as provided in the labor standards contract clauses (29CFR 5.5 (a) (1) (ii)).

The body of each wage determination lists the classification and wage rates that have been found to be prevailing for the cited type(s) of construction in the area covered by the wage determination. The classifications are listed in alphabetical order of ""identifiers"" that indicate whether the particular rate is a union rate (current union negotiated rate for local), a survey rate (weighted average rate) or a union average rate (weighted union average rate).

Union Rate Identifiers

A four letter classification abbreviation identifier enclosed in dotted lines beginning with characters other than ""SU"" or ""UAVG"" denotes that the union classification and rate were prevailing for that classification in the survey. Example: PLUM0198-005 07/01/2014. PLUM is an abbreviation identifier of the union which prevailed in the survey for this classification, which in this example would be Plumbers. 0198 indicates the local union number or district council number where applicable, i.e., Plumbers Local 0198. The next number, 005 in the example, is an internal number used in processing the wage determination. 07/01/2014 is the effective date of the most current negotiated rate, which in this example is July 1, 2014.

Union prevailing wage rates are updated to reflect all rate changes in the collective bargaining agreement (CBA) governing this classification and rate.

Survey Rate Identifiers

Classifications listed under the ""SU"" identifier indicate that no one rate prevailed for this classification in the survey and the published rate is derived by computing a weighted average rate based on all the rates reported in the survey for that classification. As this weighted average rate includes all rates reported in the survey, it may include both union and non-union rates. Example: SULA2012-007 5/13/2014. SU indicates

the rates are survey rates based on a weighted average calculation of rates and are not majority rates. LA indicates the State of Louisiana. 2012 is the year of survey on which these classifications and rates are based. The next number, 007 in the example, is an internal number used in producing the wage determination. 5/13/2014 indicates the survey completion date for the classifications and rates under that identifier.

Survey wage rates are not updated and remain in effect until a new survey is conducted.

Union Average Rate Identifiers

Classification(s) listed under the UAVG identifier indicate that no single majority rate prevailed for those classifications; however, 100% of the data reported for the classifications was union data. EXAMPLE: UAVG-OH-0010 08/29/2014. UAVG indicates that the rate is a weighted union average rate. OH indicates the state. The next number, 0010 in the example, is an internal number used in producing the wage determination. 08/29/2014 indicates the survey completion date for the classifications and rates under that identifier.

A UAVG rate will be updated once a year, usually in January of each year, to reflect a weighted average of the current negotiated/CBA rate of the union locals from which the rate is based.

WAGE DETERMINATION APPEALS PROCESS

1.) Has there been an initial decision in the matter? This can be:

- * an existing published wage determination
- * a survey underlying a wage determination
- * a Wage and Hour Division letter setting forth a position on a wage determination matter
- * a conformance (additional classification and rate) ruling

On survey related matters, initial contact, including requests for summaries of surveys, should be with the Wage and Hour National Office because National Office has responsibility for the Davis-Bacon survey program. If the response from this initial contact is not satisfactory, then the process described in 2.) and 3.) should be followed.

With regard to any other matter not yet ripe for the formal process described here, initial contact should be with the Branch of Construction Wage Determinations. Write to:

Branch of Construction Wage Determinations
Wage and Hour Division
U.S. Department of Labor
200 Constitution Avenue, N.W.
Washington, DC 20210

2.) If the answer to the question in 1.) is yes, then an interested party (those affected by the action) can request review and reconsideration from the Wage and Hour Administrator (See 29 CFR Part 1.8 and 29 CFR Part 7). Write to:

Wage and Hour Administrator
U.S. Department of Labor
200 Constitution Avenue, N.W.
Washington, DC 20210

The request should be accompanied by a full statement of the interested party's position and by any information (wage payment data, project description, area practice material, etc.) that the requestor considers relevant to the issue.

3.) If the decision of the Administrator is not favorable, an interested party may appeal directly to the Administrative Review Board (formerly the Wage Appeals Board). Write to:

Administrative Review Board
U.S. Department of Labor
200 Constitution Avenue, N.W.
Washington, DC 20210

4.) All decisions by the Administrative Review Board are final.

=====
END OF GENERAL DECISIO"

A. APPLICABILITY

The Project or Program to which the construction work covered by this Contract pertains is being assisted by the United States of America, and the following Federal Labor Standards Provisions are included in this Contract pursuant to the provisions applicable to such Federal assistance.

1. Minimum wages and fringe benefits

- i. All laborers and mechanics employed or working upon the site of the work (or otherwise working in construction or development of the project under a development statute), will be paid unconditionally and not less often than once a week, and without subsequent deduction or rebate on any account (except such payroll deductions as are permitted by regulations issued by the Secretary of Labor under the Copeland Act (29 CFR part 3)), the full amount of basic hourly wages and bona fide fringe benefits (or cash equivalents thereof) due at time of payment computed at rates not less than those contained in the wage determination of the Secretary of Labor which is attached hereto and made a part hereof, regardless of any contractual relationship which may be alleged to exist between the contractor and such laborers and mechanics. As provided in 29 CFR 5.5(d) and (e), the appropriate wage determinations are effective by operation of law even if they have not been attached to the contract. Contributions made or costs reasonably anticipated for bona fide fringe benefits under the Davis-Bacon Act (40 U.S.C. 3141(2)(B)) on behalf of laborers or mechanics are considered wages paid to such laborers or mechanics, subject to the provisions of paragraph (a)(1)(v) of these contract clauses; also, regular contributions made or costs incurred for more than a weekly period (but not less often than quarterly) under plans, funds, or programs which cover the particular weekly period, are deemed to be constructively made or incurred during such weekly period. Such laborers and mechanics must be paid the appropriate wage rate and fringe benefits on the wage determination for the classification(s) of work actually performed, without regard to skill, except as provided in 29 CFR 5.5(a)(4). Laborers or mechanics performing work in more than one classification may be compensated at the rate specified for each classification for the time actually worked therein: *Provided*, That the employer's payroll records accurately set forth the time spent in each classification in which work is performed. The wage determination (including any additional classifications and wage rates conformed under 29 CFR 5.5(a)(1)(iii)) and the Davis-Bacon poster (WH-1321) must be posted at all times by the contractor and its subcontractors at the site of the work in a prominent and accessible place where it can be easily seen by the workers.

ii. Frequently recurring classifications

- A. In addition to wage and fringe benefit rates that have been determined to be prevailing under the procedures set forth in 29 CFR part 1, a wage determination may contain, pursuant to § 1.3(f), wage and fringe benefit rates for classifications of laborers and mechanics for which conformance requests are regularly submitted pursuant to 29 CFR 5.5(a)(1)(iii), provided that:
 1. The work performed by the classification is not performed by a classification in the wage determination for which a prevailing wage rate has been determined;
 2. The classification is used in the area by the construction industry; and
 3. The wage rate for the classification bears a reasonable relationship to the prevailing wage rates contained in the wage determination.
- B. The Administrator will establish wage rates for such classifications in accordance with 29 CFR 5.5(a)(1)(iii)(A)(3). Work performed in such a classification must be paid at no less than the wage and fringe benefit rate listed on the wage determination for such classification.

iii. Conformance

- A. The contracting officer must require that any class of laborers or mechanics, including helpers, which is not listed in the wage determination and which is to be employed under the contract be

classified in conformance with the wage determination. Conformance of an additional classification and wage rate and fringe benefits is appropriate only when the following criteria have been met:

1. The work to be performed by the classification requested is not performed by a classification in the wage determination; and
 2. The classification is used in the area by the construction industry; and
 3. The proposed wage rate, including any bona fide fringe benefits, bears a reasonable relationship to the wage rates contained in the wage determination.
- B. The conformance process may not be used to split, subdivide, or otherwise avoid application of classifications listed in the wage determination.
- C. If the contractor and the laborers and mechanics to be employed in the classification (if known), or their representatives, and the contracting officer agree on the classification and wage rate (including the amount designated for fringe benefits where appropriate), a report of the action taken will be sent by the contracting officer by email to DBAconformance@dol.gov. The Administrator, or an authorized representative, will approve, modify, or disapprove every additional classification action within 30 days of receipt and so advise the contracting officer or will notify the contracting officer within the 30-day period that additional time is necessary.
- D. In the event the contractor, the laborers or mechanics to be employed in the classification or their representatives, and the contracting officer do not agree on the proposed classification and wage rate (including the amount designated for fringe benefits, where appropriate), the contracting officer will, by email to DBAconformance@dol.gov, refer the questions, including the views of all interested parties and the recommendation of the contracting officer, to the Administrator for determination. The Administrator, or an authorized representative, will issue a determination within 30 days of receipt and so advise the contracting officer or will notify the contracting officer within the 30-day period that additional time is necessary.
- E. The contracting officer must promptly notify the contractor of the action taken by the Wage and Hour Division under 29 CFR 5.5 (a)(1)(iii)(C) and (D). The contractor must furnish a written copy of such determination to each affected worker or it must be posted as a part of the wage determination. The wage rate (including fringe benefits where appropriate) determined pursuant to 29 CFR 5.5 (a)(1)(iii)(C) or (D) must be paid to all workers performing work in the classification under this contract from the first day on which work is performed in the classification.

iv. Fringe benefits not expressed as an hourly rate

Whenever the minimum wage rate prescribed in the contract for a class of laborers or mechanics includes a fringe benefit which is not expressed as an hourly rate, the contractor may either pay the benefit as stated in the wage determination or may pay another bona fide fringe benefit or an hourly cash equivalent thereof.

v. Unfunded plans

If the contractor does not make payments to a trustee or other third person, the contractor may consider as part of the wages of any laborer or mechanic the amount of any costs reasonably anticipated in providing bona fide fringe benefits under a plan or program, *Provided*, That the Secretary of Labor has found, upon the written request of the contractor, in accordance with the criteria set forth in 29 CFR 5.28, that the applicable standards of the Davis-Bacon Act have been met. The Secretary of Labor may require the contractor to set aside in a separate account assets for the meeting of obligations under the plan or program.

- vi. Interest** In the event of a failure to pay all or part of the wages required by the contract, the contractor will be required to pay interest on any underpayment of wages.

2. Withholding

i. Withholding requirements

The U. S. Department of Housing and Urban Development may, upon its own action, or must, upon written request of an authorized representative of the Department of Labor, withhold or cause to be withheld from the contractor so much of the accrued payments or advances as may be considered necessary to satisfy the liabilities of the prime contractor or any subcontractor for the full amount of wages and monetary relief, including interest, required by the clauses set forth in 29 CFR 5.5(a) for violations of this contract, or to satisfy any such liabilities required by any other Federal contract, or federally assisted contract subject to Davis-Bacon labor standards, that is held by the same prime contractor (as defined in 29 CFR 5.2). The necessary funds may be withheld from the contractor under this contract, any other Federal contract with the same prime contractor, or any other federally assisted contract that is subject to Davis-Bacon labor standards requirements and is held by the same prime contractor, regardless of whether the other contract was awarded or assisted by the same agency, and such funds may be used to satisfy the contractor liability for which the funds were withheld. In the event of a contractor's failure to pay any laborer or mechanic, including any apprentice or helper working on the site of the work (or otherwise working in construction or development of the project under a development statute) all or part of the wages required by the contract, or upon the contractor's failure to submit the required records as discussed in 29 CFR 5.5(a)(3)(iv), HUD may on its own initiative and after written notice to the contractor, sponsor, applicant, owner, or other entity, as the case may be, take such action as may be necessary to cause the suspension of any further payment, advance, or guarantee of funds until such violations have ceased.

ii. Priority to withheld funds

The Department has priority to funds withheld or to be withheld in accordance with 29 CFR 5.5(a)(2)(i) or (b)(3)(i), or both, over claims to those funds by:

- A. A contractor's surety(ies), including without limitation performance bond sureties and payment bond sureties;
- B. A contracting agency for its procurement costs;
- C. A trustee(s) (either a court-appointed trustee or a U.S. trustee, or both) in bankruptcy of a contractor, or a contractor's bankruptcy estate;
- D. A contractor's assignee(s);
- E. A contractor's successor(s); or
- F. A claim asserted under the Prompt Payment Act, 31 U.S.C. 3901-3907.

3. Records and certified payrolls

i. Basic record requirements

- A. **Length of record retention.** All regular payrolls and other basic records must be maintained by the contractor and any subcontractor during the course of the work and preserved for all laborers and mechanics working at the site of the work (or otherwise working in construction or development of the project under a development statute) for a period of at least 3 years after all the work on the prime contract is completed.
- B. **Information required** Such records must contain the name; Social Security number; last known address, telephone number, and email address of each such worker; each worker's correct classification(s) of work actually performed; hourly rates of wages paid (including rates of contributions or costs anticipated for bona fide fringe benefits or cash equivalents thereof of the types described in 40 U.S.C. 3141(2)(B) of the Davis-Bacon Act); daily and weekly number of hours actually worked in total and on each covered contract; deductions made; and actual wages paid.
- C. **Additional records relating to fringe benefits.** Whenever the Secretary of Labor has found under 29 CFR 5.5(a)(1)(v) that the wages of any laborer or mechanic include the amount of any

costs reasonably anticipated in providing benefits under a plan or program described in 40 U.S.C. 3141(2)(B) of the Davis-Bacon Act, the contractor must maintain records which show that the commitment to provide such benefits is enforceable, that the plan or program is financially responsible, and that the plan or program has been communicated in writing to the laborers or mechanics affected, and records which show the costs anticipated or the actual cost incurred in providing such benefits.

D. Additional records relating to apprenticeship Contractors with apprentices working under approved programs must maintain written evidence of the registration of apprenticeship programs, the registration of the apprentices, and the ratios and wage rates prescribed in the applicable programs.

ii. Certified payroll requirements

A. Frequency and method of submission The contractor or subcontractor must submit weekly, for each week in which any DBA- or Related Acts-covered work is performed, certified payrolls to HUD if the agency is a party to the contract, but if the agency is not such a party, the contractor will submit the certified payrolls to the applicant, sponsor, owner, or other entity, as the case may be, that maintains such records, for transmission to HUD. The prime contractor is responsible for the submission of all certified payrolls by all subcontractors. A contracting agency or prime contractor may permit or require contractors to submit certified payrolls through an electronic system, as long as the electronic system requires a legally valid electronic signature; the system allows the contractor, the contracting agency, and the Department of Labor to access the certified payrolls upon request for at least 3 years after the work on the prime contract has been completed; and the contracting agency or prime contractor permits other methods of submission in situations where the contractor is unable or limited in its ability to use or access the electronic system

B. Information required The certified payrolls submitted must set out accurately and completely all of the information required to be maintained under 29 CFR 5.5(a)(3)(i)(B), except that full Social Security numbers and last known addresses, telephone numbers, and email addresses must not be included on weekly transmittals. Instead, the certified payrolls need only include an individually identifying number for each worker (*e.g.*, the last four digits of the worker's Social Security number). The required weekly certified payroll information may be submitted using Optional Form WH-347 or in any other format desired. Optional Form WH-347 is available for this purpose from the Wage and Hour Division Web site at <https://www.dol.gov/sites/dolgov/files/WHD/legacy/files/wh347.pdf> or its successor website. It is not a violation of this section for a prime contractor to require a subcontractor to provide full Social Security numbers and last known addresses, telephone numbers, and email addresses to the prime contractor for its own records, without weekly submission by the subcontractor to the sponsoring government agency (or the applicant, sponsor, owner, or other entity, as the case may be, that maintains such records).

C. Statement of Compliance Each certified payroll submitted must be accompanied by a "Statement of Compliance," signed by the contractor or subcontractor, or the contractor's or subcontractor's agent who pays or supervises the payment of the persons working on the contract, and must certify the following:

1. That the certified payroll for the payroll period contains the information required to be provided under 29 CFR 5.5(a)(3)(ii), the appropriate information and basic records are being maintained under 29 CFR 5.5 (a)(3)(i), and such information and records are correct and complete;
2. That each laborer or mechanic (including each helper and apprentice) working on the contract during the payroll period has been paid the full weekly wages earned, without rebate, either directly or indirectly, and that no deductions have been made either directly or indirectly

from the full wages earned, other than permissible deductions as set forth in 29 CFR part 3; and

3. That each laborer or mechanic has been paid not less than the applicable wage rates and fringe benefits or cash equivalents for the classification(s) of work actually performed, as specified in the applicable wage determination incorporated into the contract.
 - D. **Use of Optional Form WH-347** The weekly submission of a properly executed certification set forth on the reverse side of Optional Form WH-347 will satisfy the requirement for submission of the “Statement of Compliance” required by 29 CFR 5.5(a)(3)(ii)(C).
 - E. **Signature** The signature by the contractor, subcontractor, or the contractor’s or subcontractor’s agent must be an original handwritten signature or a legally valid electronic signature.
 - F. **Falsification** The falsification of any of the above certifications may subject the contractor or subcontractor to civil or criminal prosecution under 18 U.S.C. 1001 and 31 U.S.C. 3729.
 - G. **Length of certified payroll retention** The contractor or subcontractor must preserve all certified payrolls during the course of the work and for a period of 3 years after all the work on the prime contract is completed.
- iii. **Contracts, subcontracts, and related documents** The contractor or subcontractor must maintain this contract or subcontract and related documents including, without limitation, bids, proposals, amendments, modifications, and extensions. The contractor or subcontractor must preserve these contracts, subcontracts, and related documents during the course of the work and for a period of 3 years after all the work on the prime contract is completed.
- iv **Required disclosures and access**
 - A. **Required record disclosures and access to workers** The contractor or subcontractor must make the records required under 29 CFR 5.5(a)(3)(i)–(iii), and any other documents that HUD or the Department of Labor deems necessary to determine compliance with the labor standards provisions of any of the applicable statutes referenced by 29 CFR 5.1, available for inspection, copying, or transcription by authorized representatives of HUD or the Department of Labor, and must permit such representatives to interview workers during working hours on the job.
 - B. **Sanctions for non-compliance with records and worker access requirements** If the contractor or subcontractor fails to submit the required records or to make them available, or refuses to permit worker interviews during working hours on the job, the Federal agency may, after written notice to the contractor, sponsor, applicant, owner, or other entity, as the case may be, that maintains such records or that employs such workers, take such action as may be necessary to cause the suspension of any further payment, advance, or guarantee of funds. Furthermore, failure to submit the required records upon request or to make such records available, or to permit worker interviews during working hours on the job, may be grounds for debarment action pursuant to 29 CFR 5.12. In addition, any contractor or other person that fails to submit the required records or make those records available to WHD within the time WHD requests that the records be produced will be precluded from introducing as evidence in an administrative proceeding under 29 CFR part 6 any of the required records that were not provided or made available to WHD. WHD will take into consideration a reasonable request from the contractor or person for an extension of the time for submission of records. WHD will determine the reasonableness of the request and may consider, among other things, the location of the records and the volume of production.
 - C. **Required information disclosures** Contractors and subcontractors must maintain the full Social Security number and last known address, telephone number, and email address of each covered worker, and must provide them upon request to HUD if the agency is a party to

the contract, or to the Wage and Hour Division of the Department of Labor. If the Federal agency is not such a party to the contract, the contractor, subcontractor, or both, must, upon request, provide the full Social Security number and last known address, telephone number, and email address of each covered worker to the applicant, sponsor, owner, or other entity, as the case may be, that maintains such records, for transmission to HUD, the contractor, or the Wage and Hour Division of the Department of Labor for purposes of an investigation or other compliance action.

4. **Apprentices and equal employment opportunity**

i. **Apprentices**

- A. Rate of pay** Apprentices will be permitted to work at less than the predetermined rate for the work they perform when they are employed pursuant to and individually registered in a bona fide apprenticeship program registered with the U.S. Department of Labor, Employment and Training Administration, Office of Apprenticeship (OA), or with a State Apprenticeship Agency recognized by the OA. A person who is not individually registered in the program, but who has been certified by the OA or a State Apprenticeship Agency (where appropriate) to be eligible for probationary employment as an apprentice, will be permitted to work at less than the predetermined rate for the work they perform in the first 90 days of probationary employment as an apprentice in such a program. In the event the OA or a State Apprenticeship Agency recognized by the OA withdraws approval of an apprenticeship program, the contractor will no longer be permitted to use apprentices at less than the applicable predetermined rate for the work performed until an acceptable program is approved.
- B. Fringe benefits** Apprentices must be paid fringe benefits in accordance with the provisions of the apprenticeship program. If the apprenticeship program does not specify fringe benefits, apprentices must be paid the full amount of fringe benefits listed on the wage determination for the applicable classification. If the Administrator determines that a different practice prevails for the applicable apprentice classification, fringe benefits must be paid in accordance with that determination.
- C. Apprenticeship ratio** The allowable ratio of apprentices to journeyworkers on the job site in any craft classification must not be greater than the ratio permitted to the contractor as to the entire work force under the registered program or the ratio applicable to the locality of the project pursuant to 29 CFR 5.5(a)(4)(i)(D). Any worker listed on a payroll at an apprentice wage rate, who is not registered or otherwise employed as stated in 29 CFR 5.5(a)(4)(i)(A), must be paid not less than the applicable wage rate on the wage determination for the classification of work actually performed. In addition, any apprentice performing work on the job site in excess of the ratio permitted under this section must be paid not less than the applicable wage rate on the wage determination for the work actually performed.
- D. Reciprocity of ratios and wage rates** Where a contractor is performing construction on a project in a locality other than the locality in which its program is registered, the ratios and wage rates (expressed in percentages of the journeyworker's hourly rate) applicable within the locality in which the construction is being performed must be observed. If there is no applicable ratio or wage rate for the locality of the project, the ratio and wage rate specified in the contractor's registered program must be observed.

- ii Equal employment opportunity** The use of apprentices and journeyworkers under this part must be in conformity with the equal employment opportunity requirements of Executive Order 11246, as amended, and 29 CFR part 30.

5 **Compliance with Copeland Act requirements.** The contractor shall comply with the requirements of 29 CFR part 3, which are incorporated by reference in this contract.

6 Subcontracts. The contractor or subcontractor must insert in any subcontracts the clauses contained in 29 CFR 5.5(a)(1) through (11), along with the applicable wage determination(s) and such other clauses or contract modifications as the U.S. Department of Housing and Urban Development may by appropriate instructions require, and a clause requiring the subcontractors to include these clauses and wage determination(s) in any lower tier subcontracts. The prime contractor is responsible for the compliance by any subcontractor or lower tier subcontractor with all the contract clauses in this section. In the event of any violations of these clauses, the prime contractor and any subcontractor(s) responsible will be liable for any unpaid wages and monetary relief, including interest from the date of the underpayment or loss, due to any workers of lower-tier subcontractors, and may be subject to debarment, as appropriate.

7 Contract termination: debarment. A breach of the contract clauses in 29 CFR 5.5 may be grounds for termination of the contract, and for debarment as a contractor and a subcontractor as provided in 29 CFR 5.12.

8 Compliance with Davis-Bacon and Related Act requirements. All rulings and interpretations of the Davis-Bacon and Related Acts contained in 29 CFR parts 1, 3, and 5 are herein incorporated by reference in this contract.

9 Disputes concerning labor standards. Disputes arising out of the labor standards provisions of this contract shall not be subject to the general disputes clause of this contract. Such disputes shall be resolved in accordance with the procedures of the Department of Labor set forth in 29 CFR parts 5, 6, and 7. Disputes within the meaning of this clause include disputes between the contractor (or any of its subcontractors) and the contracting agency, the U.S. Department of Labor, or the employees or their representatives.

10. Certification of eligibility.

i. By entering into this contract, the contractor certifies that neither it nor any person or firm who has an interest in the contractor's firm is a person or firm ineligible to be awarded Government contracts by virtue of 40 U.S.C. 3144(b) or 29 CFR 5.12(a).

ii. No part of this contract shall be subcontracted to any person or firm ineligible for award of a Government contract by virtue of 40 U.S.C. 3144(b) or 29 CFR 5.12(a).

iii. The penalty for making false statements is prescribed in the U.S. Code, Title 18 Crimes and Criminal Procedure, 18 U.S.C. 1001.

11 Anti-retaliation It is unlawful for any person to discharge, demote, intimidate, threaten, restrain, coerce, blacklist, harass, or in any other manner discriminate against, or to cause any person to discharge, demote, intimidate, threaten, restrain, coerce, blacklist, harass, or in any other manner discriminate against, any worker or job applicant for:

i. Notifying any contractor of any conduct which the worker reasonably believes constitutes a violation of the DBA, Related Acts, or 29 CFR parts 1, 3, or 5;

ii. Filing any complaint, initiating or causing to be initiated any proceeding, or otherwise asserting or seeking to assert on behalf of themselves or others any right or protection under the DBA, Related Acts, or 29 CFR parts 1, 3, or 5;

iii. Cooperating in any investigation or other compliance action, or testifying in any proceeding under the DBA, Related Acts, or 29 CFR parts 1, 3, or 5; or

iv. Informing any other person about their rights under the DBA, Related Acts, or 29 CFR parts 1, 3, or 5.

B. Contract Work Hours and Safety Standards Act (CWHSSA)

The Agency Head must cause or require the contracting officer to insert the following clauses set forth in 29 CFR 5.5(b)(1), (2), (3), (4), and (5) in full, or (for contracts covered by the Federal Acquisition Regulation) by reference, in any contract in an amount in excess of \$100,000 and subject to the overtime provisions of the Contract Work Hours and Safety Standards Act. These clauses must

be inserted in addition to the clauses required by 29 CFR 5.5(a) or 4.6. As used in this paragraph, the terms “laborers and mechanics” include watchpersons and guards.

- 1. Overtime requirements.** No contractor or subcontractor contracting for any part of the contract work which may require or involve the employment of laborers or mechanics shall require or permit any such laborer or mechanic in any workweek in which he or she is employed on such work to work in excess of forty hours in such workweek unless such laborer or mechanic receives compensation at a rate not less than one and one-half times the basic rate of pay for all hours worked in excess of forty hours in such workweek.
- 2. Violation; liability for unpaid wages; liquidated damages.** In the event of any violation of the clause set forth in 29 CFR 5.5(b)(1) the contractor and any subcontractor responsible therefor shall be liable for the unpaid wages and interest from the date of the underpayment. In addition, such contractor and subcontractor shall be liable to the United States (in the case of work done under contract for the District of Columbia or a territory, to such District or to such territory), for liquidated damages. Such liquidated damages shall be computed with respect to each individual laborer or mechanic, including watchpersons and guards, employed in violation of the clause set forth in 29 CFR 5.5(b)(1), in the sum of \$31 for each calendar day on which such individual was required or permitted to work in excess of the standard workweek of forty hours without payment of the overtime wages required by the clause set forth in 29 CFR 5.5(b)(1).
- 3. Withholding for unpaid wages and liquidated damages**
 - i. Withholding process** The U.S Department of Housing and Urban Development or the recipient of Federal assistance may, upon its own action, or must, upon written request of an authorized representative of the Department of Labor, withhold or cause to be withheld from the contractor so much of the accrued payments or advances as may be considered necessary to satisfy the liabilities of the prime contractor or any subcontractor for any unpaid wages; monetary relief, including interest; and liquidated damages required by the clauses set forth in 29 CFR 5.5(b) on this contract, any other Federal contract with the same prime contractor, or any other federally assisted contract subject to the Contract Work Hours and Safety Standards Act that is held by the same prime contractor (as defined in 29 CFR 5.2). The necessary funds may be withheld from the contractor under this contract, any other Federal contract with the same prime contractor, or any other federally assisted contract that is subject to the Contract Work Hours and Safety Standards Act and is held by the same prime contractor, regardless of whether the other contract was awarded or assisted by the same agency, and such funds may be used to satisfy the contractor liability for which the funds were withheld.
 - ii Priority to withheld funds** The Department has priority to funds withheld or to be withheld in accordance with 29 CFR 5.5(a)(2)(i) or (b)(3)(i), or both, over claims to those funds by:
 - A.** A contractor’s surety(ies), including without limitation performance bond sureties and payment bond sureties;
 - B.** A contracting agency for its procurement costs;
 - C.** A trustee(s) (either a court-appointed trustee or a U.S. trustee, or both) in bankruptcy of a contractor, or a contractor’s bankruptcy estate;
 - D.** A contractor’s assignee(s);
 - E.** A contractor’s successor(s); or
 - F.** A claim asserted under the Prompt Payment Act, 31 U.S.C. 3901-3907.
- 4. Subcontracts.** The contractor or subcontractor must insert in any subcontracts the clauses set forth in 29 CFR 5.5(b)(1) through (5) and a clause requiring the subcontractors to include these clauses in any lower tier subcontracts. The prime contractor is responsible for compliance by any subcontractor or lower tier subcontractor with the clauses set forth in 29 CFR 5.5(b)(1) through (5). In the event of any violations of these clauses, the prime contractor and any subcontractor(s) responsible will be liable for any unpaid wages and monetary relief, including interest from the date of the underpayment or loss,

due to any workers of lower-tier subcontractors, and associated liquidated damages and may be subject to debarment, as appropriate.

- 5 Anti-retaliation** It is unlawful for any person to discharge, demote, intimidate, threaten, restrain, coerce, blacklist, harass, or in any other manner discriminate against, or to cause any person to discharge, demote, intimidate, threaten, restrain, coerce, blacklist, harass, or in any other manner discriminate against, any worker or job applicant for:
- i. Notifying any contractor of any conduct which the worker reasonably believes constitutes a violation of the Contract Work Hours and Safety Standards Act (CWHSSA) or its implementing regulations in 29 CFR part 5;
 - ii. Filing any complaint, initiating or causing to be initiated any proceeding, or otherwise asserting or seeking to assert on behalf of themselves or others any right or protection under CWHSSA or 29 CFR part 5;
 - iii. Cooperating in any investigation or other compliance action, or testifying in any proceeding under CWHSSA or 29 CFR part 5; or
 - iv. Informing any other person about their rights under CWHSSA or 29 CFR part 5.
- C. CWHSSA required records clause** In addition to the clauses contained in 29 CFR 5.5(b), in any contract subject only to the Contract Work Hours and Safety Standards Act and not to any of the other laws referenced by 29 CFR 5.1, the Agency Head must cause or require the contracting officer to insert a clause requiring that the contractor or subcontractor must maintain regular payrolls and other basic records during the course of the work and must preserve them for a period of 3 years after all the work on the prime contract is completed for all laborers and mechanics, including guards and watchpersons, working on the contract. Such records must contain the name; last known address, telephone number, and email address; and social security number of each such worker; each worker's correct classification(s) of work actually performed; hourly rates of wages paid; daily and weekly number of hours actually worked; deductions made and actual wages paid. Further, the Agency Head must cause or require the contracting officer to insert in any such contract a clause providing that the records to be maintained under this paragraph must be made available by the contractor or subcontractor for inspection, copying, or transcription by authorized representatives of the (write the name of agency) and the Department of Labor, and the contractor or subcontractor will permit such representatives to interview workers during working hours on the job.
- D. Incorporation of contract clauses and wage determinations by reference** Although agencies are required to insert the contract clauses set forth in this section, along with appropriate wage determinations, in full into covered contracts, and contractors and subcontractors are required to insert them in any lower-tier subcontracts, the incorporation by reference of the required contract clauses and appropriate wage determinations will be given the same force and effect as if they were inserted in full text.
- E. Incorporation by operation of law** The contract clauses set forth in this section (or their equivalent under the Federal Acquisition Regulation), along with the correct wage determinations, will be considered to be a part of every prime contract required by the applicable statutes referenced by 29 CFR 5.1 to include such clauses, and will be effective by operation of law, whether or not they are included or incorporated by reference into such contract, unless the Administrator grants a variance, tolerance, or exemption from the application of this paragraph. Where the clauses and applicable wage determinations are effective by operation of law under this paragraph, the prime contractor must be compensated for any resulting increase in wages in accordance with applicable law.

F. HEALTH AND SAFETY

The provisions of this paragraph (F) are applicable where the amount of the prime contract exceeds **\$100,000**.

1. No laborer or mechanic shall be required to work in surroundings or under working conditions which are unsanitary, hazardous, or dangerous to his or her health and safety, as determined under construction safety and health standards promulgated by the Secretary of Labor by regulation.
2. The contractor shall comply with all regulations issued by the Secretary of Labor pursuant to 29 CFR Part 1926 and failure to comply may result in imposition of sanctions pursuant to the Contract Work Hours and Safety Standards Act, (Public Law 91-54, 83 Stat 96), 40 U.S.C. § 3701 et seq.
3. The contractor shall include the provisions of this paragraph in every subcontract, so that such provisions will be binding on each subcontractor. The contractor shall take such action with respect to any subcontractor as the Secretary of Housing and Urban Development or the Secretary of Labor shall direct as a means of enforcing such provisions.



2024-CR-2 CDBG: ADA CURB RAMP INSTALLATION

SHEET INDEX

- | | |
|-----------------------------------|-------------------------------------|
| 1.) COVER SHEET | 9.) W. 18TH ST. & N. CLEBURN ST. |
| 2.) N. WHEELER AVE. & W. 18TH ST. | 10.) W. 17TH ST. & N. CLEBURN ST. |
| 3.) 220 W. 18TH ST. | 11.) W. 17TH ST. & N. ELM ST. |
| 4.) N. WHEELER AVE. & W. 19TH ST. | 12.) W. 17TH ST. & N. CEDAR ST. |
| 5.) N. WHEELER AVE. & W. 20TH ST. | 13.) W. STATE ST. & N. CEDAR ST. |
| 6.) N. WHEELER AVE. & W. 21ST ST. | 14.) N. GREENWICH ST. & W. 12TH ST. |
| 7.) N. WHEELER AVE. & W. 22ND ST. | TC TRAFFIC CONTROL |
| 8.) N. WHEELER AVE. & W. 23RD ST. | TC TRAFFIC CONTROL |

NOTES

1. THE LOCATION OF ALL UNDERGROUND UTILITY FACILITIES HAS NOT BEEN IDENTIFIED ON THESE PLANS. THE UNDERGROUND UTILITIES SHALL BE LOCATED AND FLAGGED BY THE UTILITIES AT THE REQUEST OF THE CONTRACTOR. NO EXCAVATION SHALL BE PERMITTED IN THE AREA OF THE UNDERGROUND UTILITIES UNTIL ALL SUCH FACILITIES HAVE BEEN LOCATED. EXCAVATION MUST BE ACCOMPLISHED WITH EXTREME CARE IN ORDER TO AVOID ANY POSSIBILITY OF DAMAGE TO THE UTILITY. THE CONTRACTOR SHALL BE RESPONSIBLE FOR ALL DAMAGES AND THE COSTS TO REPAIR THE DAMAGES.
2. THE LOCATION AND DIMENSIONS SHOWN ON THESE PLANS FOR REMOVALS AND CONSTRUCTION OF THE CURB RAMPS IS FOR INFORMATION ONLY. CITY OF GRAND ISLAND SHALL FIELD IDENTIFY REMOVAL LIMITS PRIOR TO CONSTRUCTION.
3. ALL WORK SHALL BE DONE IN ACCORDANCE WITH THE CITY OF GRAND ISLAND PLANS, SPECIFICATIONS AND SPECIAL PROVISIONS.
4. THE CONTRACTOR SHALL PRESERVE ALL PROPERTY CORNER MONUMENTS OR RE-ESTABLISH THEM IF THEY ARE DISTURBED DURING CONSTRUCTION.
5. THE SURFACE OF ALL CURB RAMPS SHALL BE BROOMED PERPENDICULAR TO THE SLOPE OF THE CURB RAMP
6. CARE SHALL BE TAKEN TO ASSURE A UNIFORM GRADE ON THE RAMP. FREE OF SAGS AND SHORT GRADE CHANGES.
7. DETECTABLE WARNING PANEL SHALL EXTEND THE FULL WIDTH OF THE CURB RAMP
8. TURNING SPACE SHALL HAVE MINIMUM DIMENSIONS OF 4 FT. x 4FT. AND SHALL BE A MINIMUM OF 1 FT. FROM ANY OBSTACLE SUCH AS A CURB OR RETAINING WALL FOR SWING OF WHEELCHAIR FOOT REST. THE SLOPE SHALL BE 2% MAXIMUM IN ANY DIRECTION.

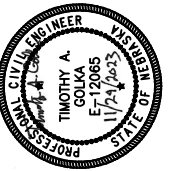
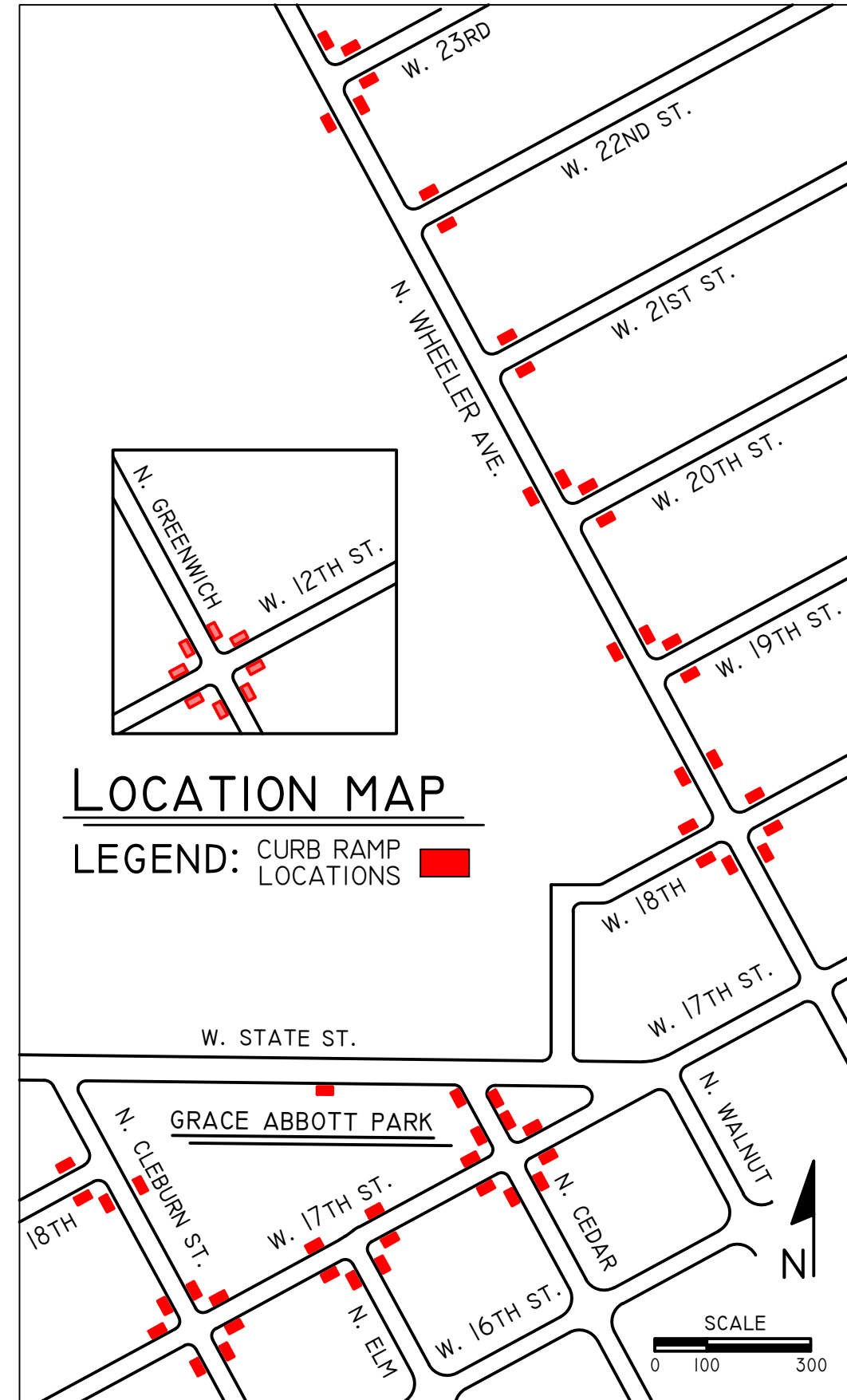

NOTES & REVISIONS	
SURVEYED BY: T.J.Y.	DATE: 08-11-2023
DRAWN BY: T.J.Y.	DATE: 08-25-2023
CHECKED BY: TAG	DATE: 11-28-2023
APPROVED BY: TAG	DATE: 11-28-2023

REMOVE WALK 535.95 SQ. FT.
 BUILD WALK: 384.74 SQ. FT.
 BUILD WALK W/CURB: 168.03 SQ. FT.
 SAW CUT: 186.34 LF.
 REMOVE PAVEMENT 48.42 SQ. YD.
 BUILD PAVEMENT: 48.42 SQ. YD.
 BUILD CURB: 145.10 LF.
 WARNING PLATES: 48.00 SQ. FT.
 SOD: 37.16 SQ. YD.
 ADJUST AREA INLET: 1 EA.
 REMOVE & RESET LANDSCAPING BLOCK: 45.77 LF.

N. WHEELER AVE.

W. 18TH ST.

SIDEWALK W/CURB

SIDEWALK W/CURB

REMOVE & RESET LANDSCAPING BLOCKS

ADJUST AREA INLET

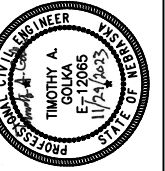
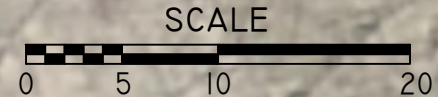

NOTES & REVISIONS

NO.	DATE	BY	REVISION
1	08-11-2023	TJY	SURVEYED BY
2	08-11-2023	TJY	DATE
3	08-25-2023	TJY	DRAWN BY
4	08-25-2023	TAG	DATE
5	11-28-2023	TAG	CHECKED BY
6	11-28-2023	TAG	DATE
7	11-28-2023	TAG	APPROVED BY
8	11-28-2023	TAG	DATE

N. WHEELER AVE. & W. 18TH ST.

2024 CR-2 CDBG

GRAND ISLAND, NEBRASKA

SHEET

2 OF 14

DWG : J:\SIDEWALKS\PROJECTS\HANDICAP RAMP PROJECTS\2024 CR-2 CDBG\PLAN DRAWINGS\MASTER XREFS\COVER_WHEELER.DWG 11/30/2023 1:16:55 PM

REMOVE WALK 224.67 SQ. FT.
 BUILD WALK W/CURB 251.49 SQ. FT.
 BUILD WALK: 60.01 FT.
 SAW CUT: 37.20 LF.
 REMOVE PAVEMENT 6.48 SQ. YD.
 BUILD PAVEMENT: 6.48 SQ. YD.
 BUILD CURB: 29.20 LF.
 WARNING PLATES: 16.00 SQ. FT.
 SOD: 43.24 SQ. YD.

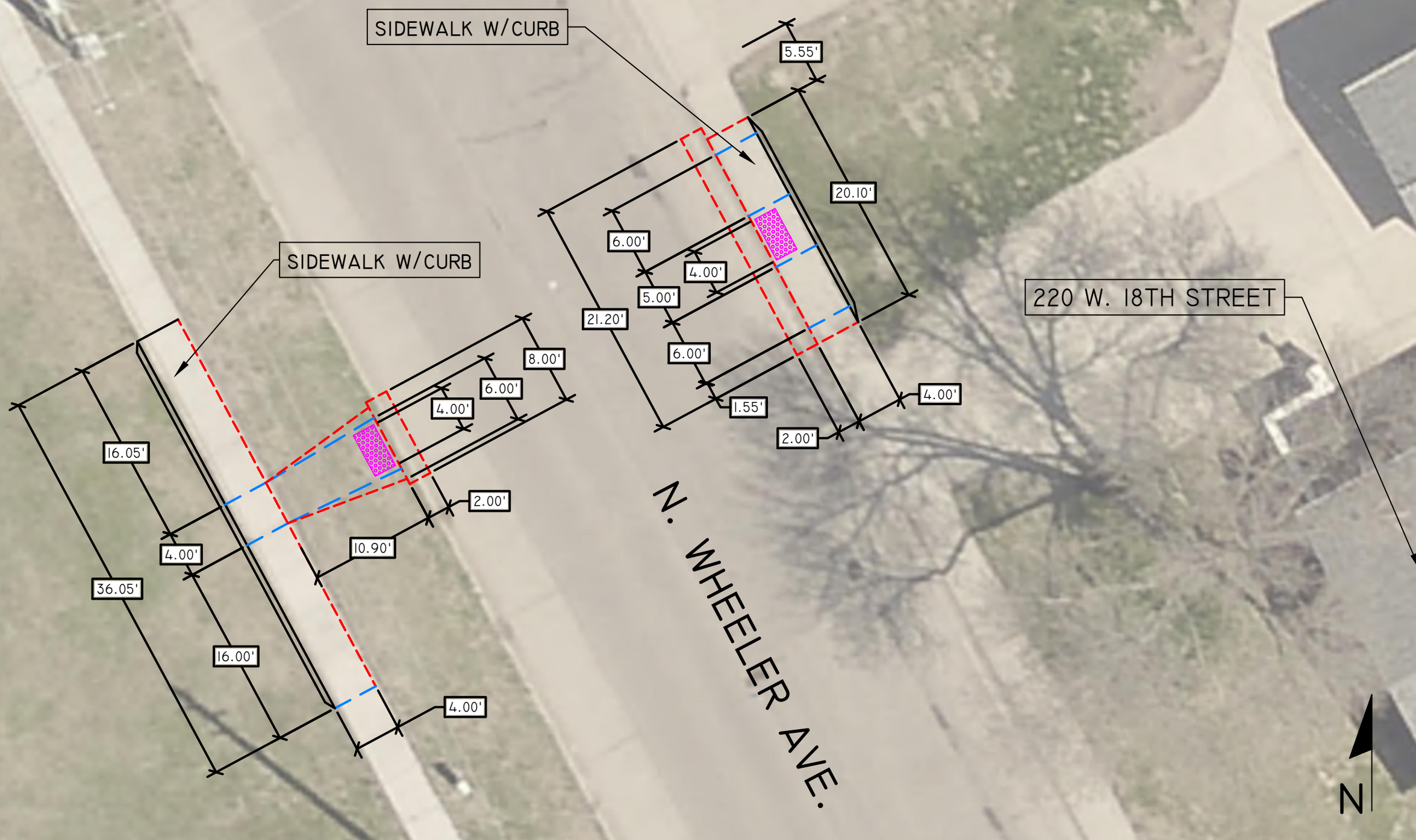

DWG : J:\SIDEWALKS\PROJECTS\HANDICAP RAMP PROJECTS\2024 CR-2 CDBG\PLAN DRAWINGS\MASTER XREFS\COVER_WHEELER.DWG 11/30/2023 10:54:11 PM

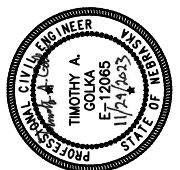

NOTES & REVISIONS	
SURVEYED BY: T.J.	DATE: 08-11-2023
DRAWN BY: T.J.	DATE: 08-25-2023
CHECKED BY: TAG	DATE: 11-28-2023
APPROVED BY: TAG	DATE: 11-28-2023

220 W. 18TH ST & N. WHEELER AVE.
 2024 CR-2 CDBG
 GRAND ISLAND, NEBRASKA

REMOVE WALK 476.15 SQ. FT.
 BUILD WALK W/CURB 77.55 SQ. FT.
 BUILD WALK: 449.99 FT.
 SAW CUT: 102.73 LF.
 REMOVE PAVEMENT 21.47 SQ. YD.
 BUILD PAVEMENT: 21.47 SQ. YD.
 BUILD CURB: 83.98 LF.
 WARNING PLATES: 32.00 SQ. FT.
 SOD: 53.60 SQ. YD.
 ADJUST INLET: 2 EA.

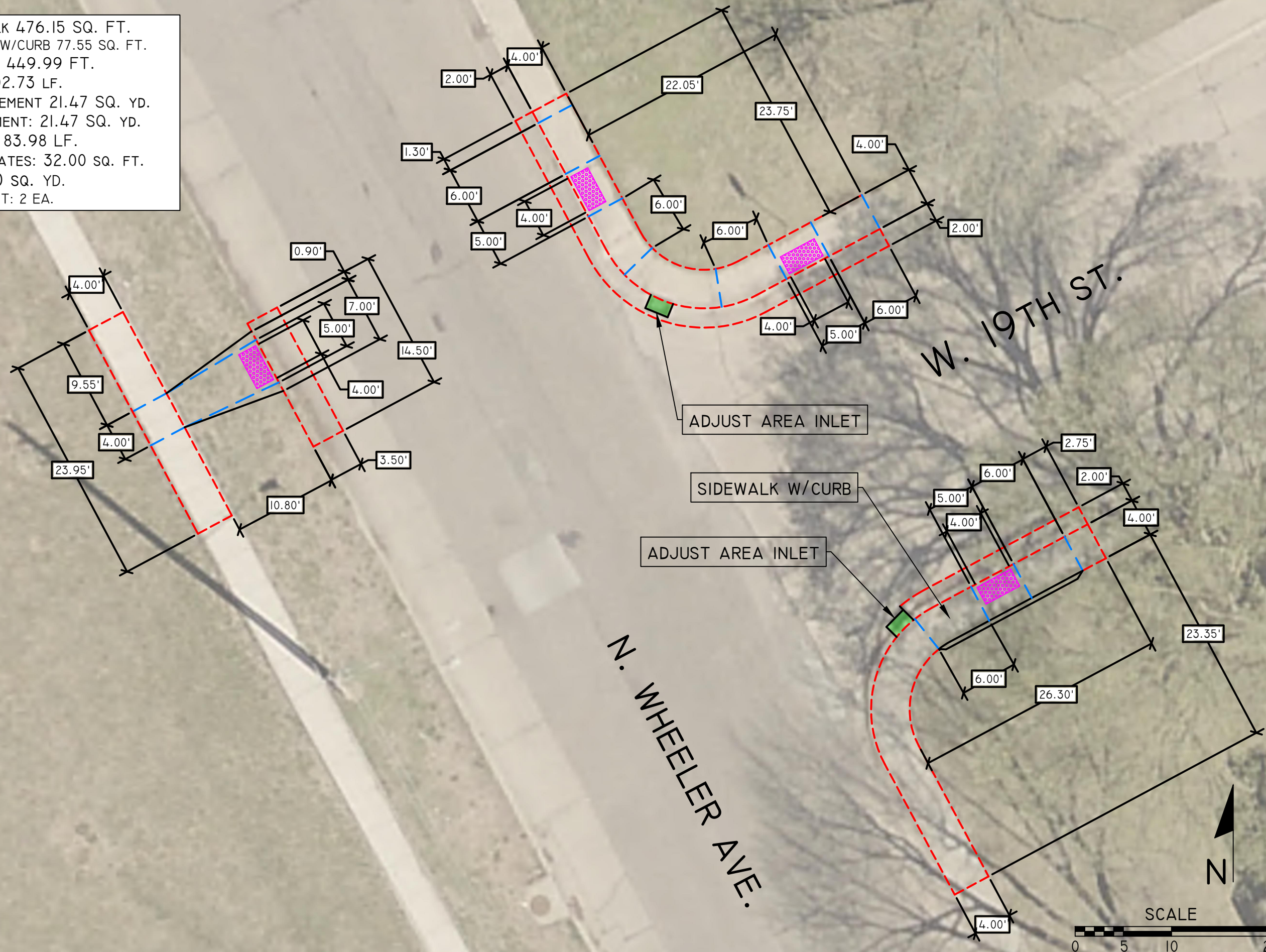

DWG : J:\SIDEWALKS\PROJECTS\HANDICAP RAMP PROJECTS\2024 CR-2 CDBG\PLAN DRAWINGS\MASTER XREFS\COVER_WHEELER.DWG 11/30/2023 1:46:49 PM

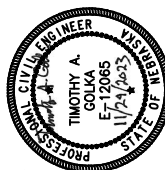

NOTES & REVISIONS

NO.	DATE	BY	REVISION
1	08-11-2023	TJF	SURVEYED BY: TJF
2	08-25-2023	TAG	CHECKED BY: TAG
3	11-28-2023	TAG	APPROVED BY: TAG
4	11-28-2023	TAG	DATE: 11-28-2023

N. WHEELER AVE. & W. 19TH ST.
 2024 CR-2 CDBG
 GRAND ISLAND, NEBRASKA

REMOVE WALK 335.44 SQ. FT.
 BUILD WALK: 397.50 SQ. FT.
 SAW CUT: 102.88 LF.
 REMOVE PAVEMENT 18.94 SQ. YD.
 BUILD PAVEMENT: 18.94 SQ. YD.
 BUILD CURB: 83.55 LF.
 WARNING PLATES: 32 SQ. FT.
 SOD: 29.93 SQ. YD.

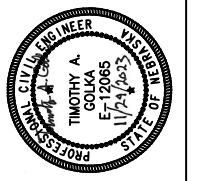
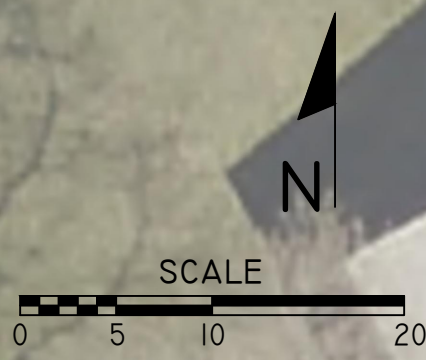
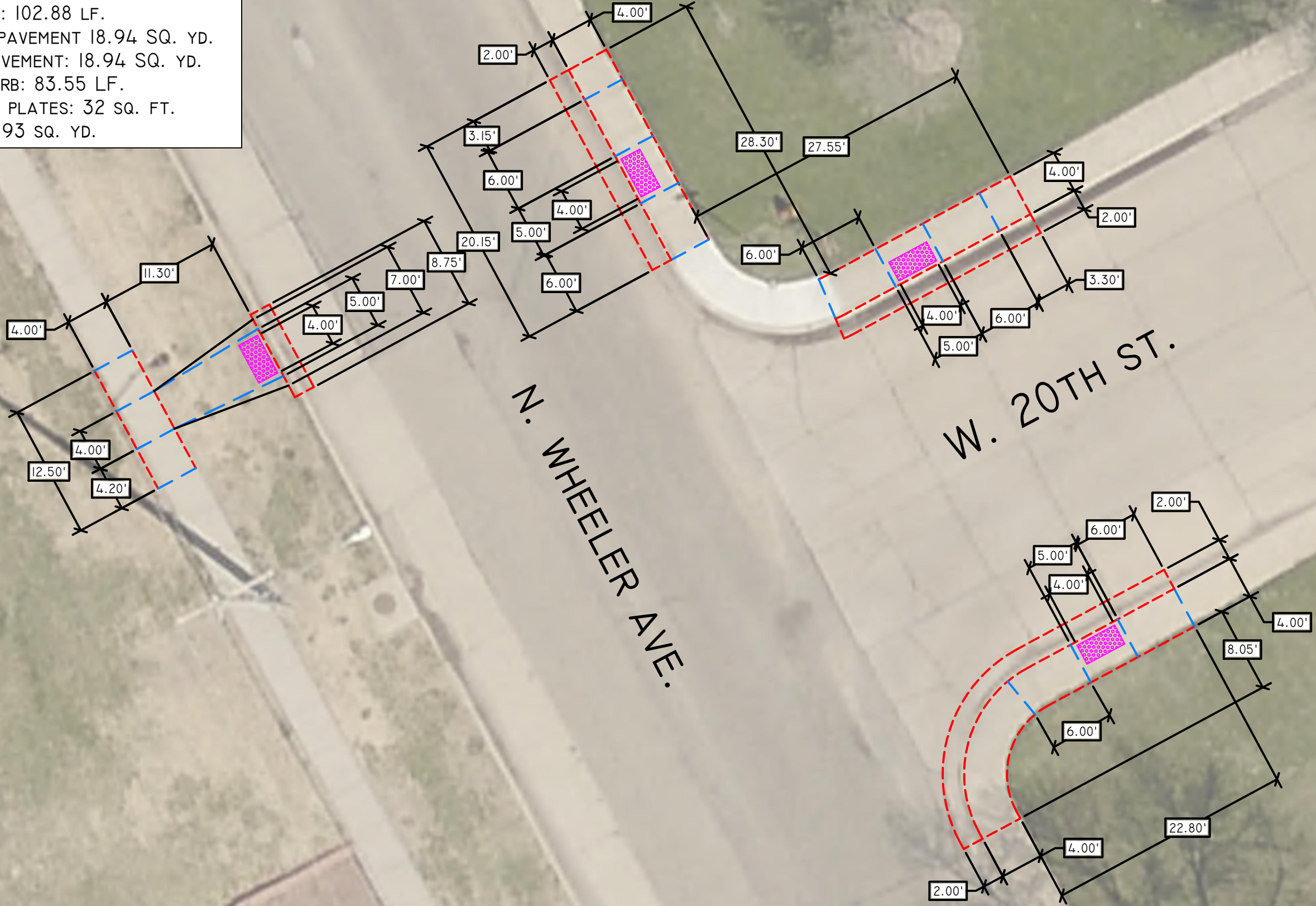

NOTES & REVISIONS

NO.	DATE	BY	REVISION
1	08-11-2023	TJY	SURVEYED BY: TJY
2	08-25-2023	TJY	DATE: 08-11-2023
3	11-28-2023	TAG	DRAWN BY: TJY
4	11-28-2023	TAG	DATE: 08-25-2023
5	11-28-2023	TAG	CHECKED BY: TAG
6	11-28-2023	TAG	DATE: 11-28-2023
7	11-28-2023	TAG	APPROVED BY: TAG
8	11-28-2023	TAG	DATE: 11-28-2023

N. WHEELER AVE. & W. 20TH ST.
 2024 CR-2 CDBG
 GRAND ISLAND, NEBRASKA

DWG : J:\SIDEWALKS\PROJECTS\HANDICAP RAMP PROJECTS\2024 CR-2 CDBG\PLAN DRAWINGS\MASTER XREFS\COVER_WHEELER.DWG 11/30/2023 1:44:53 PM

REMOVE WALK 178.66 SQ. FT.
 BUILD WALK: 178.66 SQ. FT.
 SAW CUT: 82.99 LF.
 REMOVE PAVEMENT 10.75 SQ. YD.
 BUILD PAVEMENT: 10.75 SQ. YD.
 BUILD CURB: 47.16 LF.
 WARNING PLATES: 16 SQ. FT.
 SOD: 9.09 SQ. YD.

N. WHEELER AVE.

W. 21ST ST.

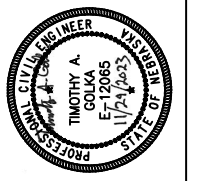
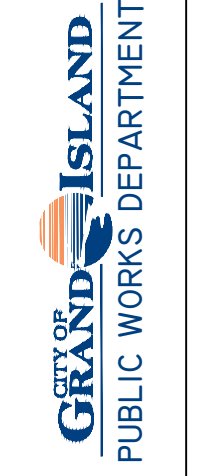
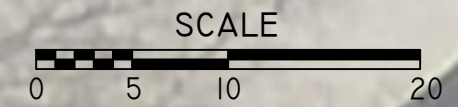
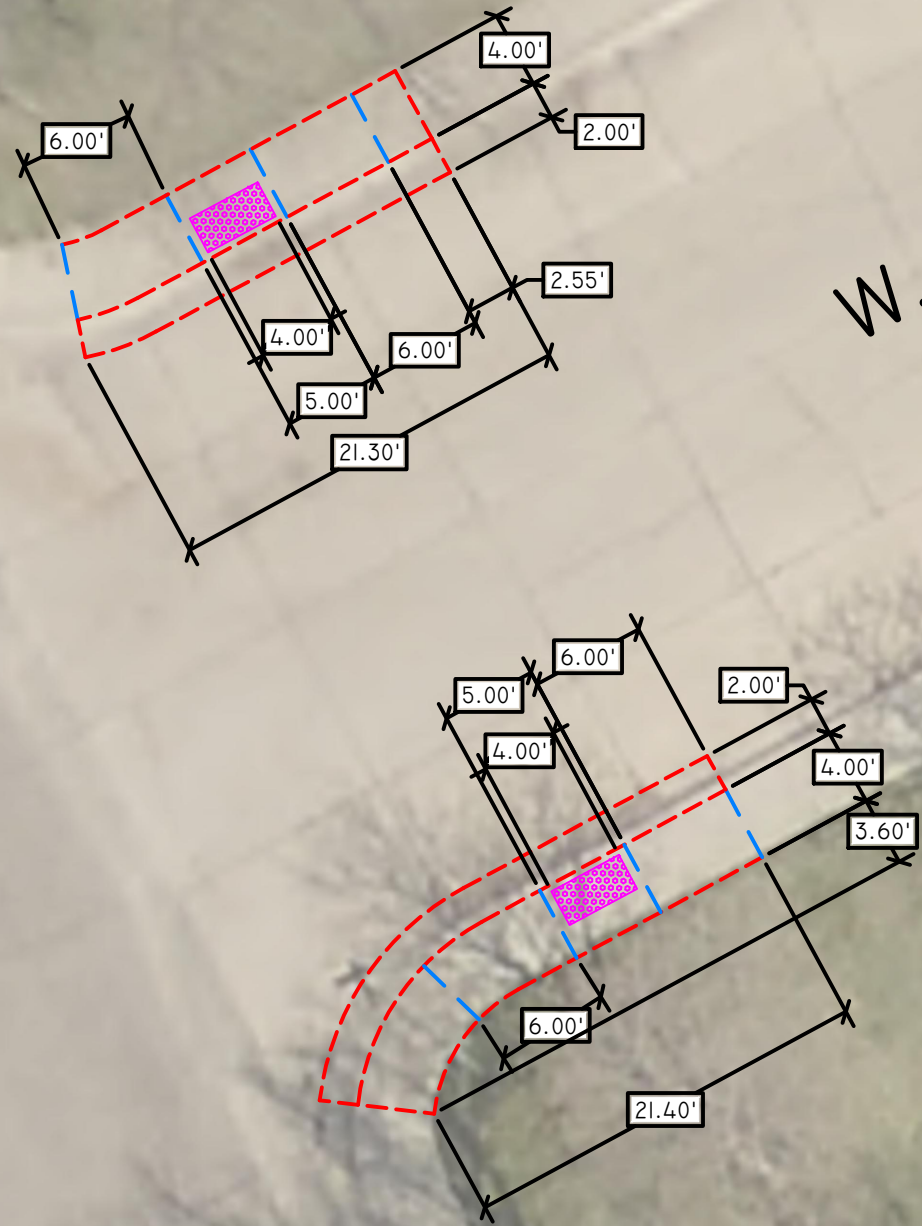

NOTES & REVISIONS

SURVEYED BY:	TJV
DATE:	08-1-2023
DRAWN BY:	TJV
DATE:	08-25-2023
CHECKED BY:	TAG
DATE:	11-28-2023
APPROVED BY:	TAG
DATE:	11-28-2023

N. WHEELER AVE. & W. 21ST ST.
 2024 CR-2 CDBG
 GRAND ISLAND, NEBRASKA

DWG : J:\SIDEWALKS\PROJECTS\HANDICAP RAMP PROJECTS\2024 CR-2 CDBG\PLAN DRAWINGS\MASTER XREFS\COVER_WHEELER.DWG 11/30/2023 1:53:14 PM

REMOVE WALK 192.79 SQ. FT.
 BUILD WALK: 192.79 SQ. FT.
 SAW CUT: 52.08 LF.
 REMOVE PAVEMENT 11.37 SQ. YD.
 BUILD PAVEMENT: 11.37 SQ. YD.
 BUILD CURB: 39.82 LF.
 WARNING PLATES: 16 SQ. FT.
 SOD: 9.42 SQ. YD.

N. WHEELER AVE.

W. 22ND ST.

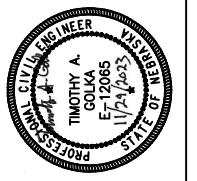
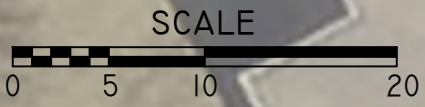
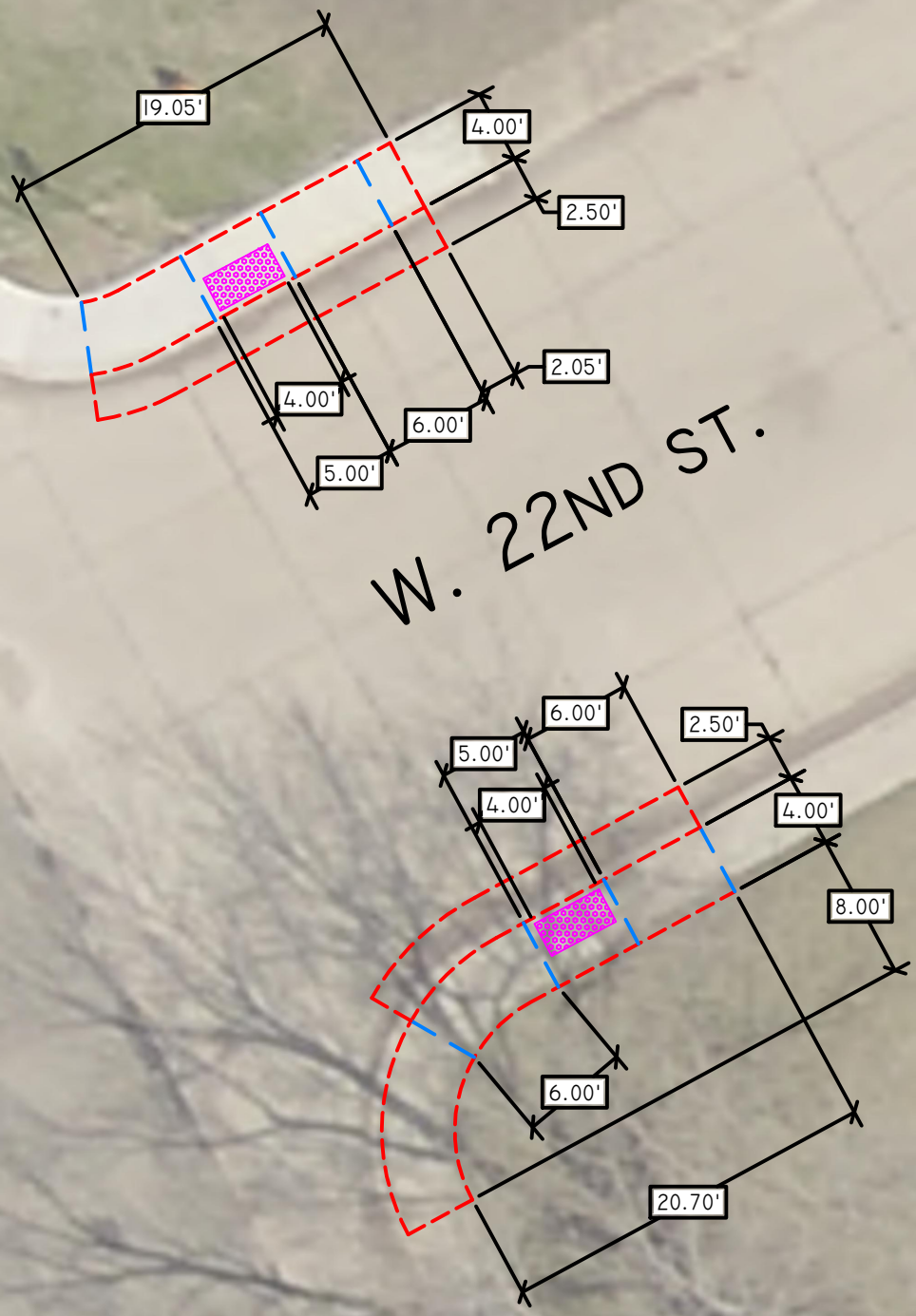

NOTES & REVISIONS

SURVEYED BY:	TJV
DATE:	08-1-2023
DRAWN BY:	TJV
DATE:	08-25-2023
CHECKED BY:	TAG
DATE:	11-28-2023
APPROVED BY:	TAG
DATE:	11-28-2023

N. WHEELER AVE. & W. 22ND ST.
 2024 CR-2 CDBG
 GRAND ISLAND, NEBRASKA

DWG : J:\SIDEWALKS\PROJECTS\HANDICAP RAMP PROJECTS\2024 CR-2 CDBG\PLAN DRAWINGS\MASTER XREFS\COVER_WHEELER.DWG 11/30/2023 11:21:8 PM

REMOVE WALK 370.04 SQ. FT.
 BUILD WALK: 439.53 SQ. FT.
 SAW CUT: 135.99 LF.
 REMOVE PAVEMENT 33.47 SQ. YD.
 BUILD PAVEMENT: 33.47 SQ. YD.
 BUILD CURB: 109.43 LF.
 WARNING PLATES: 42 SQ. FT.
 SOD: 31.91 SQ. YD.

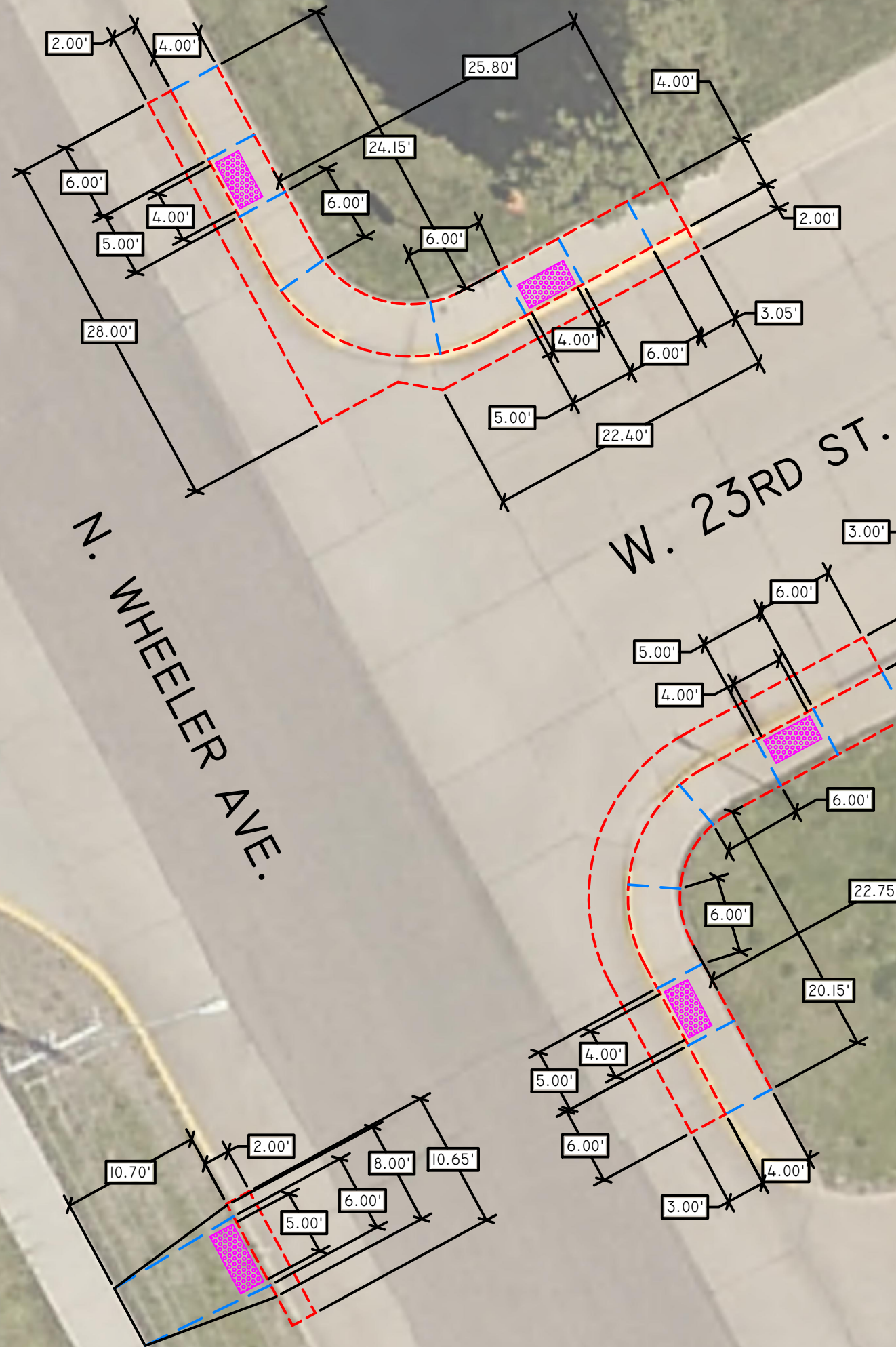

DWG : J:\SIDEWALKS\PROJECTS\HANDICAP RAMP PROJECTS\2024 CR-2 CDBG\PLAN DRAWINGS\MASTER XREFS\COVER_WHEELER.DWG 11/30/2023 11:15:36 PM

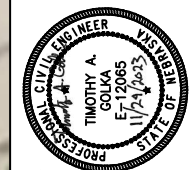

NOTES & REVISIONS	
SURVEYED BY:	TJY
DATE:	08-11-2023
DRAWN BY:	TJY
DATE:	08-25-2023
CHECKED BY:	TAG
DATE:	11-28-2023
APPROVED BY:	TAG
DATE:	11-28-2023

N. WHEELER AVE. & W. 23RD ST.
 2024 CR-2 CDBG
 GRAND ISLAND, NEBRASKA

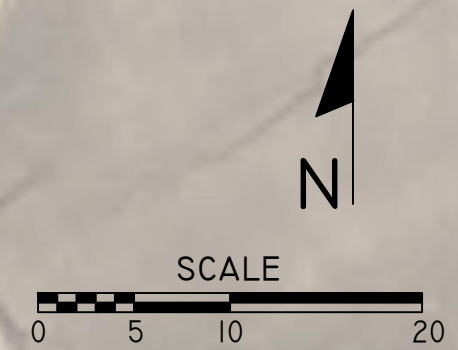

REMOVE WALK 420.63 SQ. FT.
 BUILD WALK: 401.14 SQ. FT.
 SAW CUT: 115.94 LF.
 REMOVE PAVEMENT 33.88 SQ. YD.
 BUILD PAVEMENT: 33.88 SQ. YD.
 BUILD CURB: 75.55 LF.
 WARNING PLATES: 36.00 SQ. FT.
 SOD: 20.00 SQ. YD.
 BUILD STAMPED CONCRETE: 112.25 SQ. FT.

N. CLEBURN ST.

W. 18TH ST.

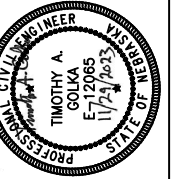
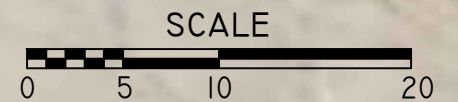
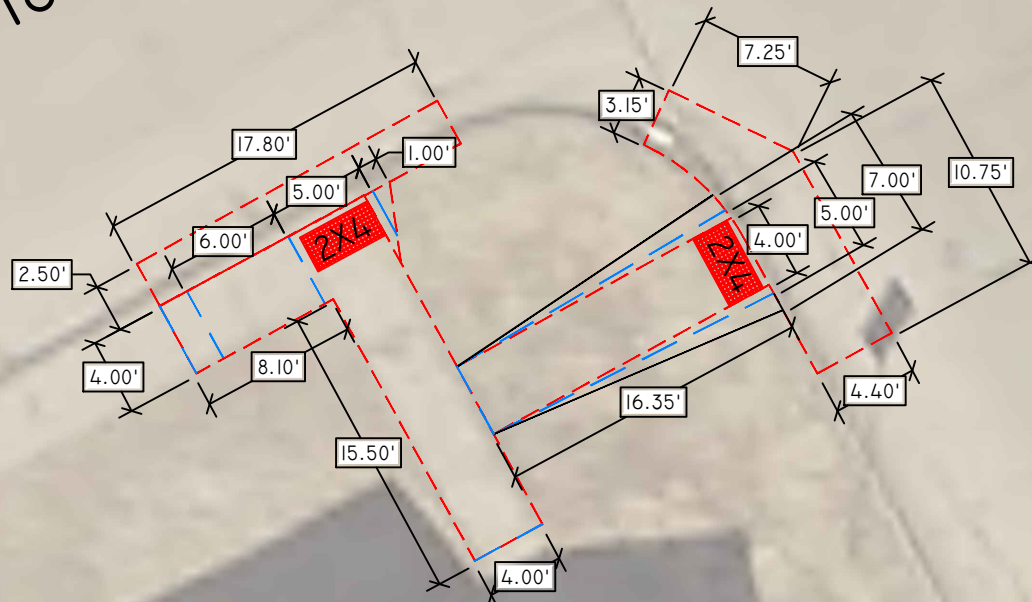
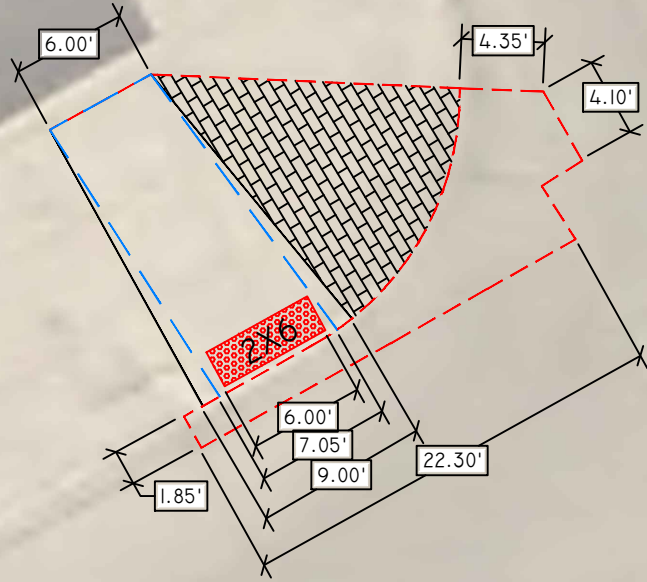

NOTES & REVISIONS	
SURVEYED BY: JLY	DATE: 07-27-2023
DRAWN BY: JDB	DATE: 08-18-2023
CHECKED BY: TAG	DATE: 11-28-2023
APPROVED BY: TAG	DATE: 11-28-2023

W. 18TH & N. CLEBURN ST.

2024 CR-2 CDBG
 GRAND ISLAND, NEBRASKA

SHEET

9 OF 14

DWG : J:\SIDEWALKS\PROJECTS\HANDICAP RAMP PROJECTS\2024 CR-2 CDBG\PLAN DRAWINGS\MASTER XREFS\IGRACE ABBOT PARK_CR-2.DWG 11/30/2023 1:36:56 PM

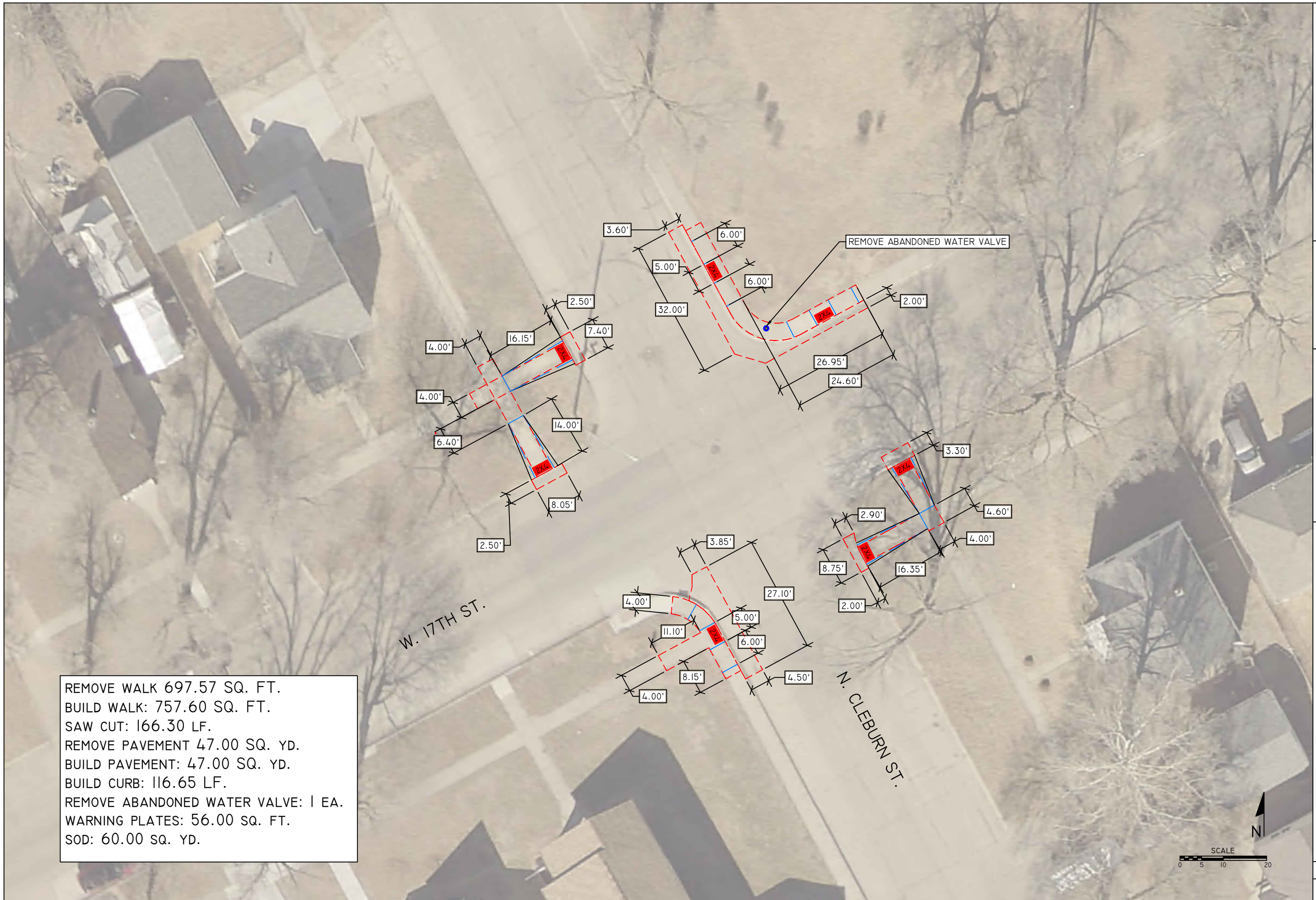

REMOVE WALK 697.57 SQ. FT.
 BUILD WALK: 757.60 SQ. FT.
 SAW CUT: 166.30 LF.
 REMOVE PAVEMENT 47.00 SQ. YD.
 BUILD PAVEMENT: 47.00 SQ. YD.
 BUILD CURB: 116.65 LF.
 REMOVE ABANDONED WATER VALVE: 1 EA.
 WARNING PLATES: 56.00 SQ. FT.
 SOD: 60.00 SQ. YD.

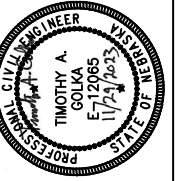

NOTES & REVISIONS

NO.	DATE	BY	REVISION
1	07-27-2023	JDB	SURVEYED BY: JDB
2	08-18-2023	JDB	DATE: 07-27-2023
3	11-28-2023	TAG	DRAWN BY: TAG
4	11-28-2023	TAG	DATE: 08-18-2023
5	11-28-2023	TAG	CHECKED BY: TAG
6	11-28-2023	TAG	DATE: 11-28-2023
7	11-28-2023	TAG	APPROVED BY: TAG
8	11-28-2023	TAG	DATE: 11-28-2023

W. 17TH & N. CLEBURN ST.

2024 CR-2 CDBG
 GRAND ISLAND, NEBRASKA

SHEET

10 OF 14

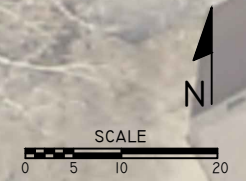

DWG : J:\SIDEWALKS\PROJECTS\HANDICAP RAMP PROJECTS\2024 CR-2 CDBG\PLAN DRAWINGS\MASTER XREFS\IGRACE ABBOT PARK_CR-2.DWG 11/30/2023 1:38:34 PM

REMOVE WALK 540.25 SQ. FT.
BUILD WALK: 581.97 SQ. FT.
SAW CUT: 139.52 LF.
REMOVE PAVEMENT 29.53 SQ. YD.
BUILD PAVEMENT: 29.53 SQ. YD.
BUILD CURB: 112.20 LF.
ADJUST MH TO GRADE: 1 EA.
WARNING PLATES: 48.00 SQ. FT.
SOD: 45.00 SQ. YD.

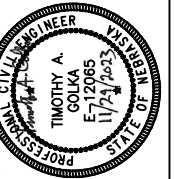
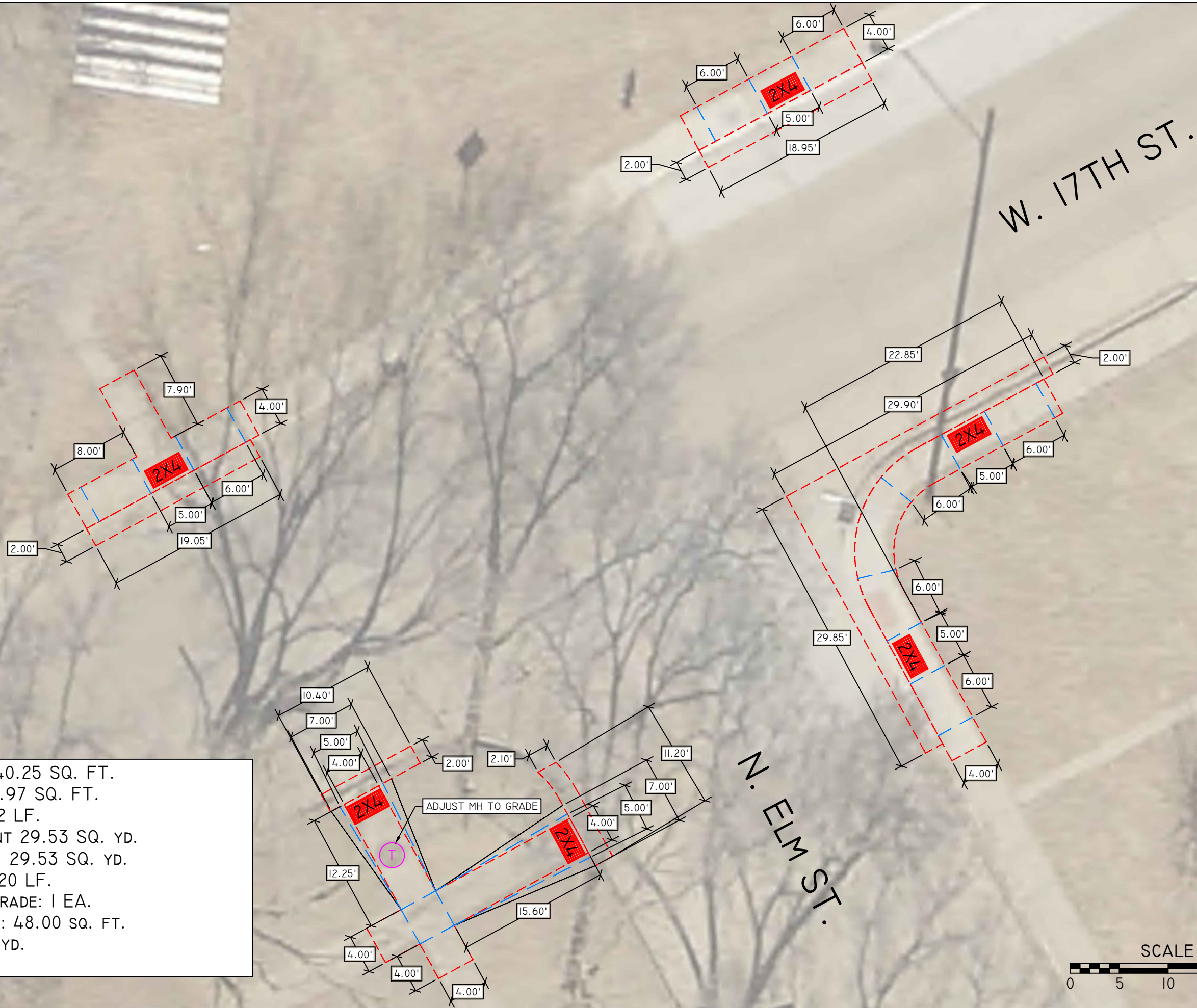

NOTES & REVISIONS	
SURVEYED BY: T.V.	DATE: 07-27-2023
DRAWN BY: JDB	DATE: 08-18-2023
CHECKED BY: TAG	DATE: 11-21-2023
APPROVED BY: TAG	DATE: 11-28-2023

W. 17TH & N. ELM ST.

2024 CR-2 CDBG
GRAND ISLAND, NEBRASKA

SHEET

11 OF 14

DWG : J:\SIDEWALKS\PROJECTS\HANDICAP RAMP PROJECTS\2024 CR-2 CDBG\PLAN DRAWINGS\MASTER XREFS\IGRACE ABBOTT PARK_CR-2.DWG 11/30/2023 1:37:40 PM

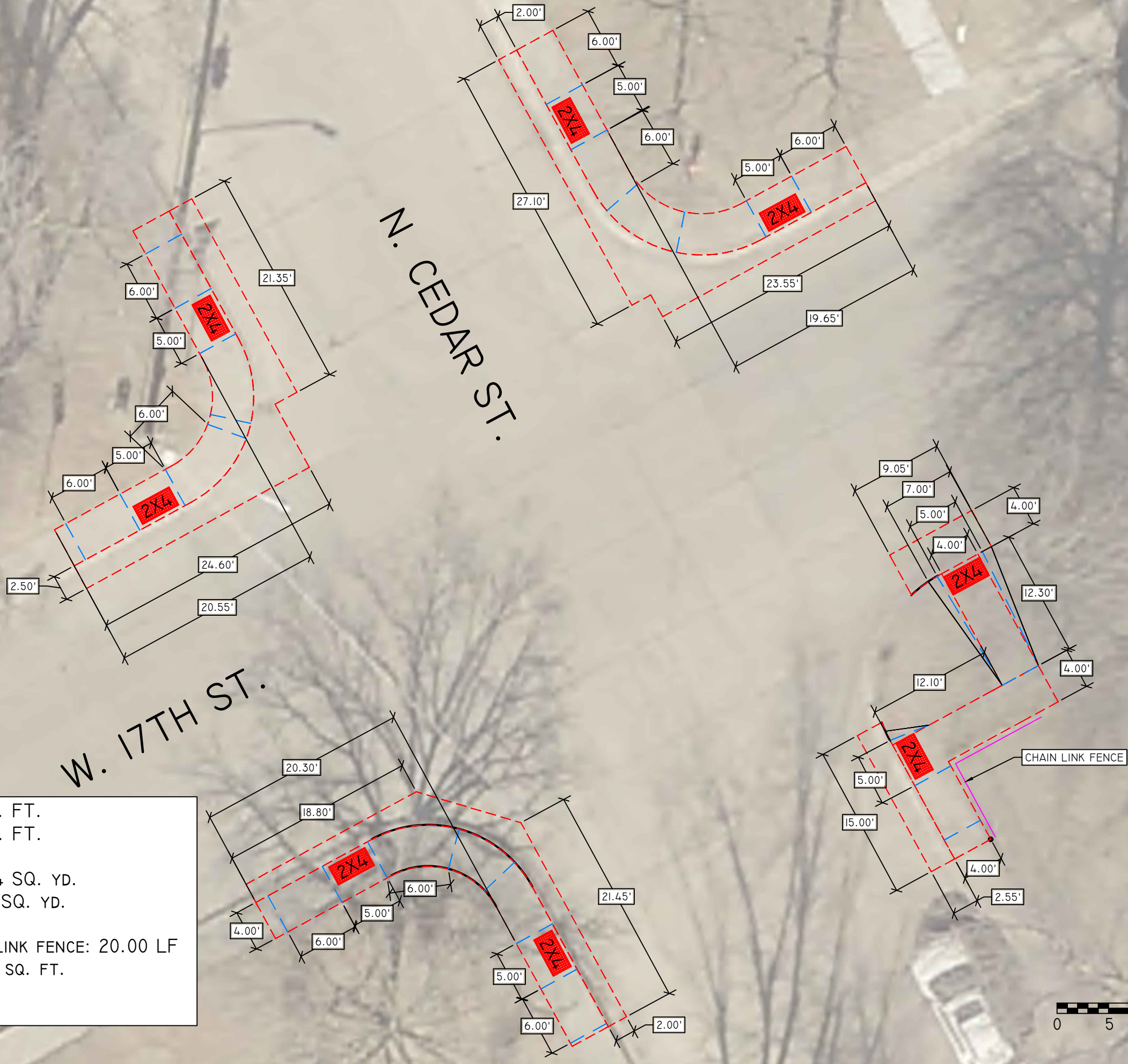

REMOVE WALK 611.78 SQ. FT.
 BUILD WALK: 682.56 SQ. FT.
 SAW CUT: 211.36 LF.
 REMOVE PAVEMENT 50.94 SQ. YD.
 BUILD PAVEMENT: 50.94 SQ. YD.
 BUILD CURB: 162.45 LF.
 REMOVE/REPLACE CHAIN LINK FENCE: 20.00 LF
 WARNING PLATES: 64.00 SQ. FT.
 SOD: 50.00 SQ. YD.

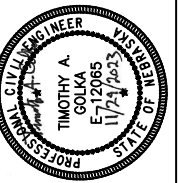

NOTES & REVISIONS

NO.	DATE	BY	REVISION
1	07-27-2023	JDB	SURVEYED BY: JLY
2	08-18-2023	TAG	DATE: 07-27-2023
3	11-28-2023	TAG	DRAWN BY: JDB
4	11-28-2023	TAG	DATE: 08-18-2023
5	11-28-2023	TAG	CHECKED BY: TAG
6	11-28-2023	TAG	DATE: 11-28-2023
7	11-28-2023	TAG	APPROVED BY: TAG
8	11-28-2023	TAG	DATE: 11-28-2023

W. 17TH & N. CEDAR ST.

2024 CR-2 CDBG

GRAND ISLAND, NEBRASKA

SHEET

12 OF 14

REMOVE WALK 314.07 SQ. FT.
 BUILD WALK: 325.00 SQ. FT.
 SAW CUT: 23.09 LF.
 REMOVE PAVEMENT 21.86 SQ. YD.
 BUILD PAVEMENT: 21.86 SQ. YD.
 BUILD CURB: 73.92 LF.
 WARNING PLATES: 24 SQ. FT.
 SOD: 21.00 SQ. YD.

W. STATE ST.

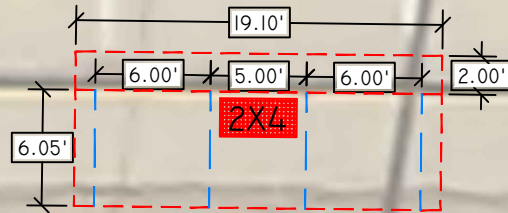

W. STATE ST.

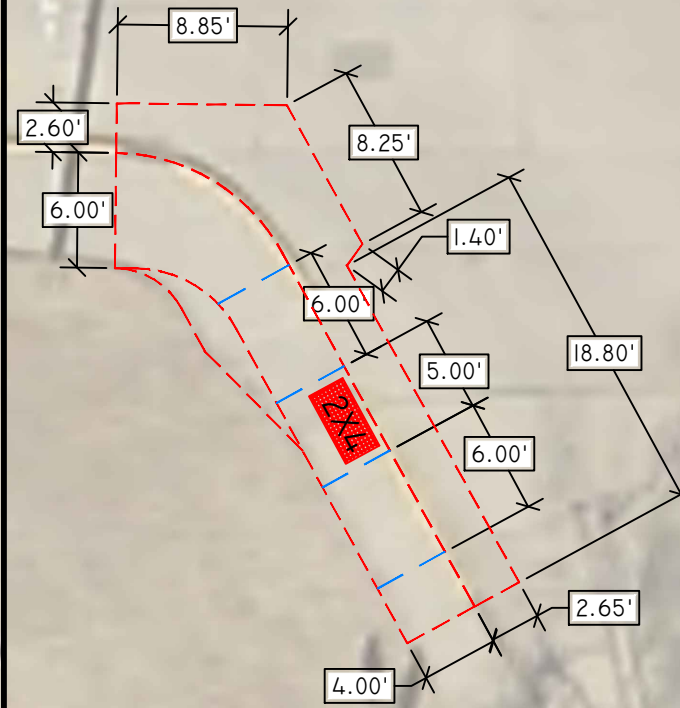

N. CEDAR ST.

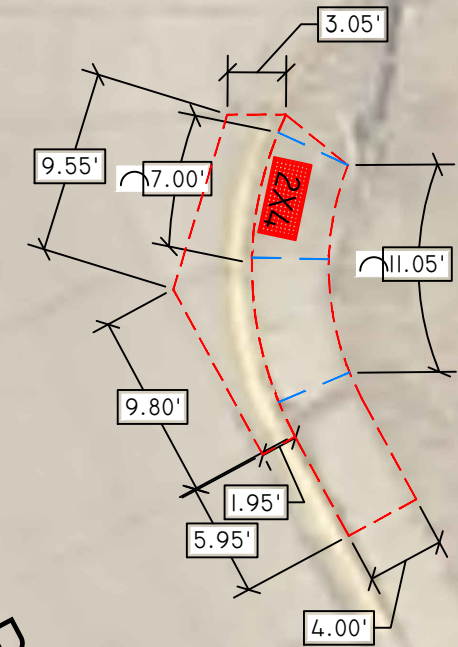

SCALE

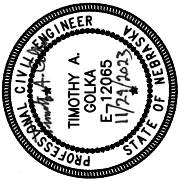
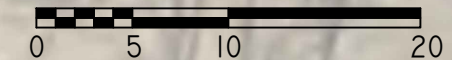

NOTES & REVISIONS	
SURVEYED BY: JLY	DATE: 07-27-2023
DRAWN BY: JDB	DATE: 08-18-2023
CHECKED BY: TAG	DATE: 11-28-2023
APPROVED BY: TAG	DATE: 11-28-2023

N CEDAR ST. & W. STATE ST.

2024 CR-2 CDBG

GRAND ISLAND, NEBRASKA

SHEET

13 OF 14

REMOVE WALK 679.64 SQ. FT.
 BUILD WALK: 871.41 SQ. FT.
 SAW CUT: 122.32 LF.
 REMOVE PAVEMENT 21.13 SQ. YD.
 BUILD PAVEMENT: 21.13 SQ. YD.
 BUILD CURB: 89.42 LF.
 WARNING PLATES: 64 SQ. FT.
 SOD: 65.00 SQ. YD.

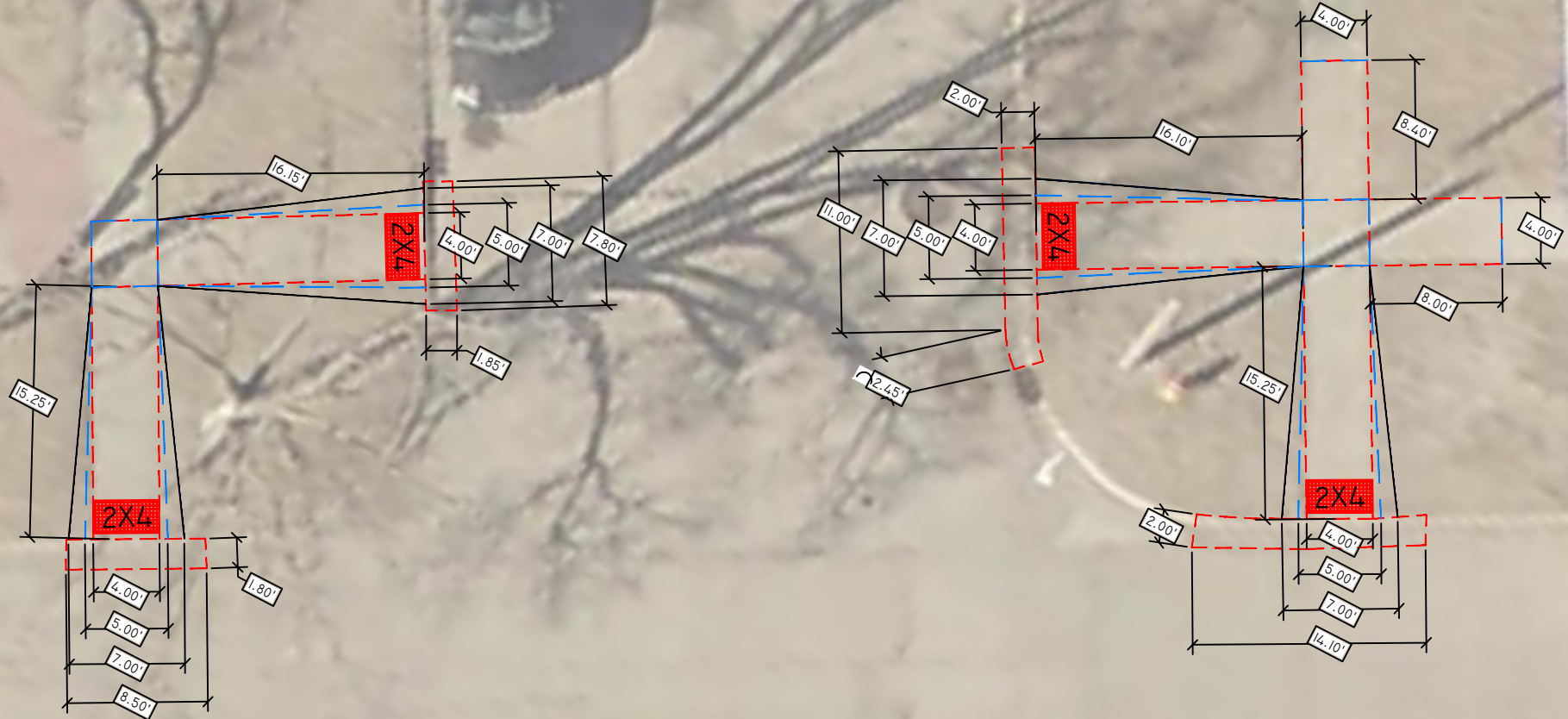

W. 12TH ST.

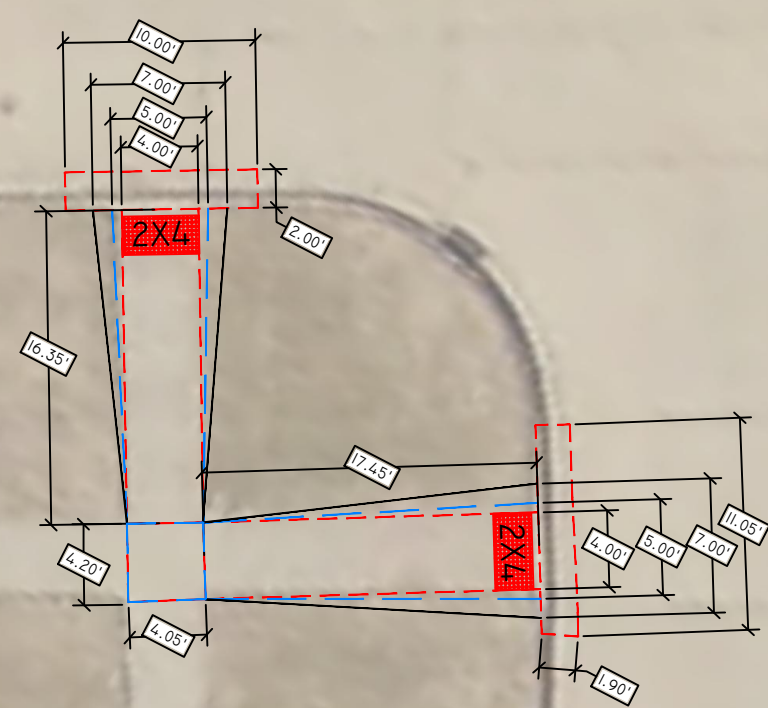

N. GREENWICH ST.

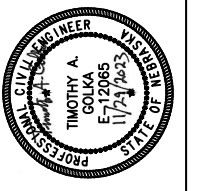
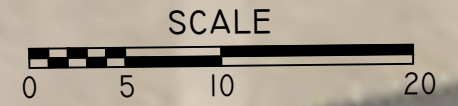
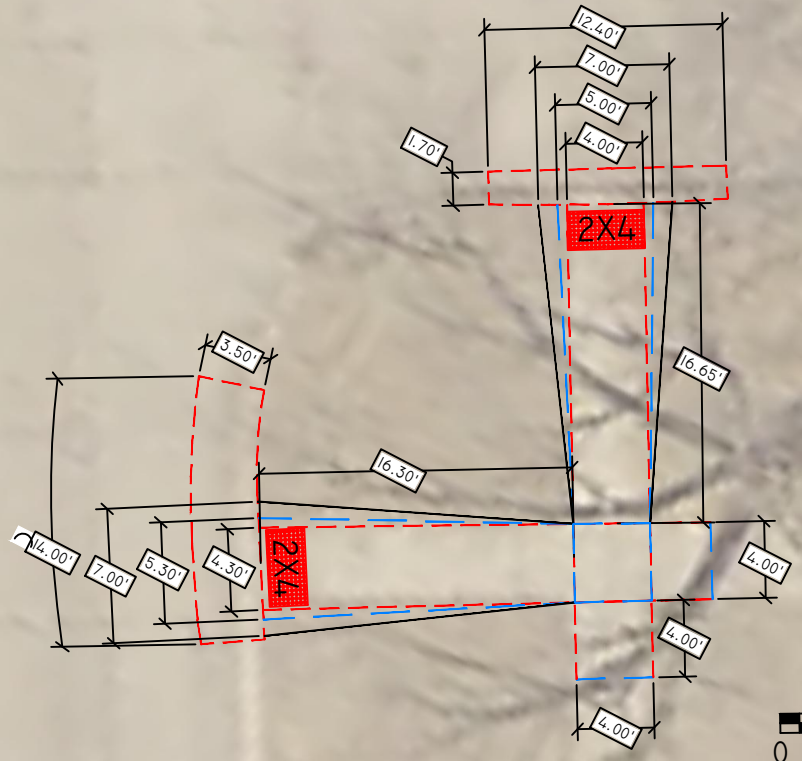

NOTES & REVISIONS

NO.	DATE	BY	REVISION
1	06-15-2023	JOB	SURVEYED BY:
2	08-11-2023	JOB	DATE:
3	11-28-2023	TAG	DRAWN BY:
4	11-28-2023	TAG	DATE:
5	11-28-2023	TAG	CHECKED BY:
6	11-28-2023	TAG	DATE:
7	11-28-2023	TAG	APPROVED BY:
8	11-28-2023	TAG	DATE:

N. GREENWICH & W. 12TH ST.
 2024 CR-2 CDBG
 GRAND ISLAND, NEBRASKA

DWG : J:\SIDEWALKS\PROJECTS\HANDICAP RAMP PROJECTS\2024 CR-2 CDBG\PLAN DRAWINGS\MASTER XREFS\12TH_GREENWICH_CR-2.DWG 11/30/2023 1:48:26 PM

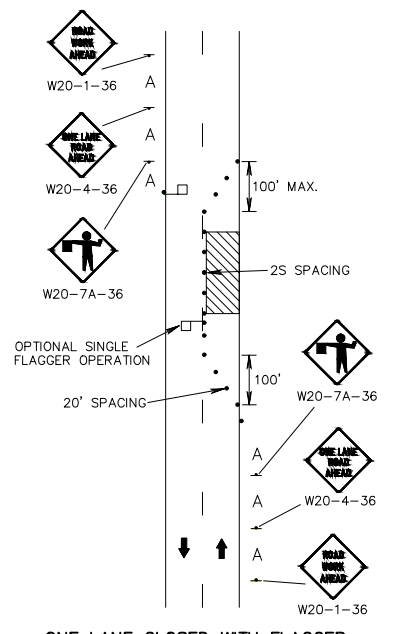

ONE LANE CLOSED WITH FLAGGER

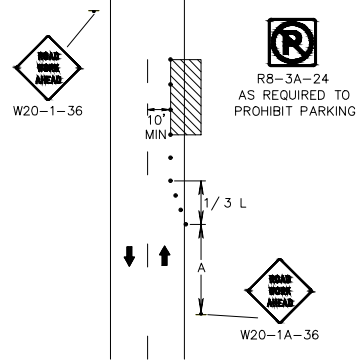

SHOULDER OR PARKING LANE CLOSED

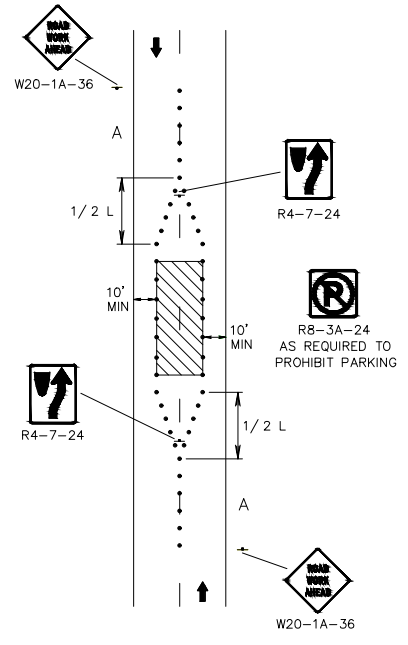

WORK IN CENTER OF ROAD WITH LOW TRAFFIC VOLUMES

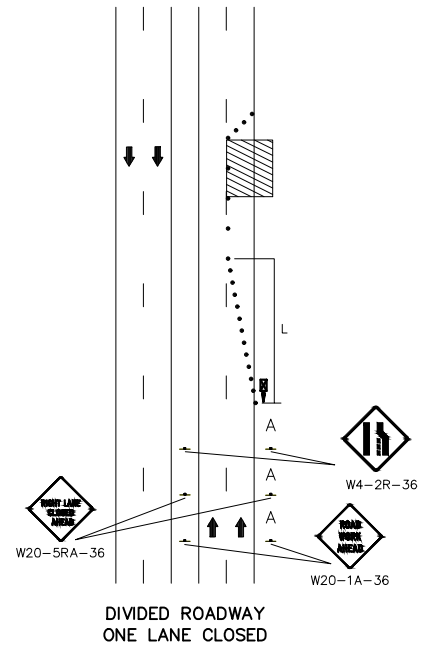

DIVIDED ROADWAY ONE LANE CLOSED

LEGEND

- ⚡ FLASHING ARROW PANEL
- | TYPE III BARRICADE
- REFLECTORIZED PLASTIC DRUM OR TYPE II BARRICADE (SEE NOTE 6)
- ↑ SIGN
- △ 28" CONES OR 28" TUBULAR POST

TAPER FORMULA

- L = MERGING TAPER
- L/2 = SHIFTING TAPER
- L/3 = SHOULDER TAPER
- L = W x S FOR SPEEDS OF 45 MPH OR HIGHER
- L = $\frac{WS^2}{60}$ FOR SPEEDS OF 40 MPH OR LOWER
- L = MINIMUM LENGTH OF TAPER
- S = NUMERICAL VALUE OF POSTED SPEED LIMIT PRIOR TO WORK
- W = WIDTH OF OFFSET

GENERAL NOTES

1. ALL BARRICADE AND SIGN LOCATIONS ON THIS PLAN ARE APPROXIMATE, AND MAY BE ADJUSTED TO FIT FIELD CONDITIONS. THE SIGNS SHALL BE INSTALLED SO AS NOT TO OBSCURE THE VIEW OF OTHER TRAFFIC CONTROL DEVICES.
2. MINIMUM WIDTH OF TRAVELLED LANE SHALL BE AS REQUIRED BY THE ENGINEER.
3. FLASHING ARROW PANEL REQUIRED ON ALL ROADWAYS WITH POSTED SPEED LIMIT 45 MPH OR HIGHER.
4. LONG TERM FLASHING ARROW PANELS IN URBAN RESIDENTIAL AREAS WHERE DIESEL ENGINE NOISE WILL BE DISRUPTIVE TO RESIDENTS, MAY BE REQUIRED TO OPERATE BY 120 VAC OR, IF SIGHT DISTANCE ALLOWS A SOLAR POWERED ARROW PANEL MAY BE USED.
5. THE MAXIMUM SPACING BETWEEN CHANNELIZING DEVICES IN A TAPER SHOULD BE APPROXIMATELY EQUAL IN FEET TO THE SPEED LIMIT. WHERE USED ALONG THE WORK AREA, THE SPACING MAY BE INCREASED TO TWO S SPACING.
6. SUBSTITUTION OF CONES, IF IN ACCORDANCE WITH SECTION 6F.64 OF THE MANUAL ON UNIFORM TRAFFIC CONTROL DEVICES, IS PERMITTED.

ROAD TYPE	MINIMUM DISTANCE BETWEEN SIGNS
	A
URBAN (LOW SPEED - 25 MPH TO 40 MPH)	150
URBAN (HIGH SPEED - GREATER THAN 45 MPH)	350

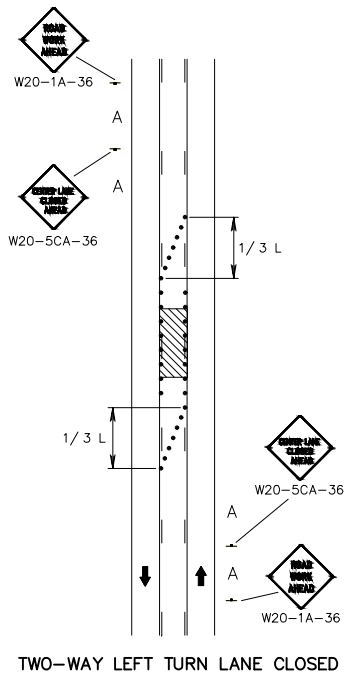

TWO-WAY LEFT TURN LANE CLOSED

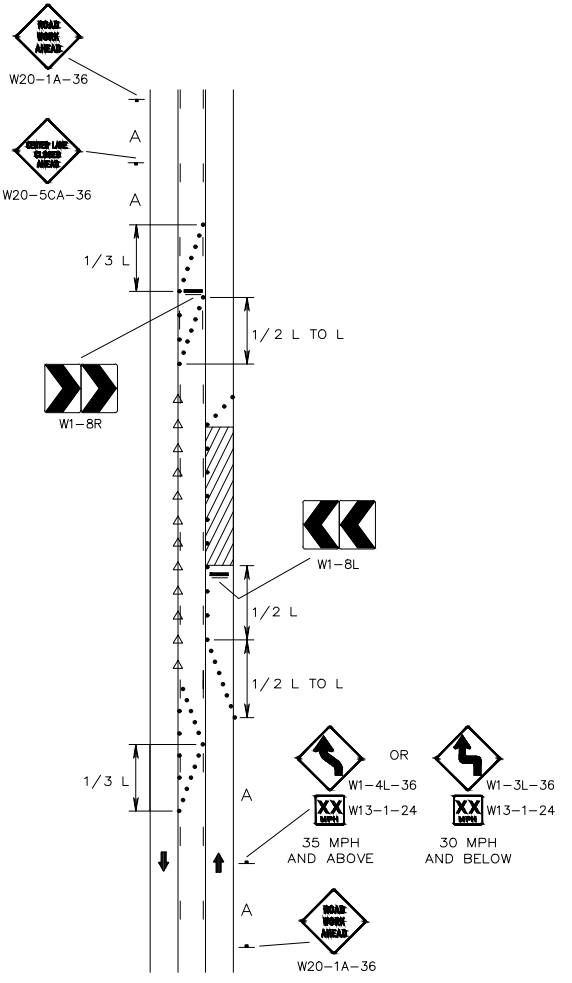

3-LANE ROADWAY ONE LANE CLOSED

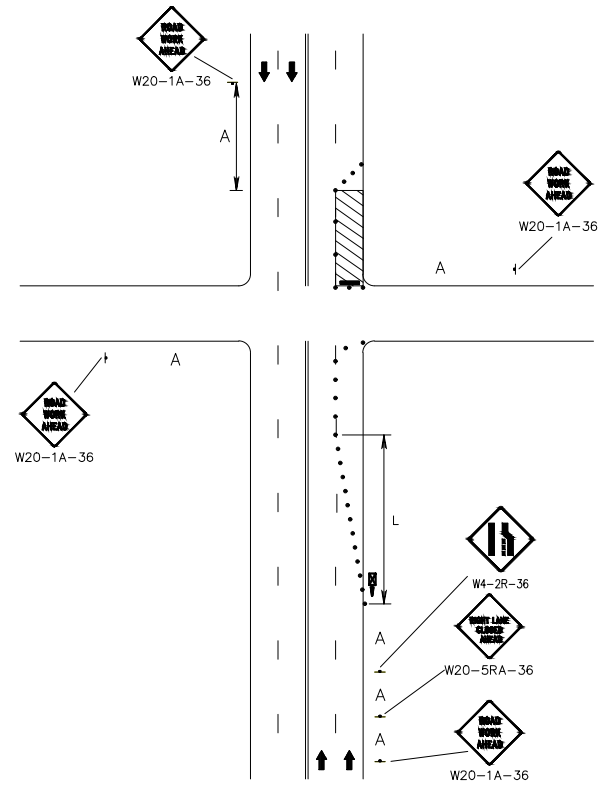

LANE CLOSED NEAR INTERSECTION (RIGHT LANE CLOSED)

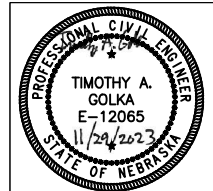

CITY OF GRAND ISLAND ENGINEERING DIVISION

TYPICAL TRAFFIC CONTROL PLAN

DESIGNED: 12/10 SG
REVIEWED:

TYPICAL URBAN TRAFFIC CONTROL PLAN

TTC-1

MERGING TAPER (L) 12' WIDTH

SPEED	DESCRIPTION
25	8 CONES AT 20' SPACES
30	10 CONES AT 20' SPACES
35	11 CONES AT 25' SPACES
40	11 CONES AT 35' SPACES
45	13 CONES AT 45' SPACES

S = POSTED SPEED LIMIT

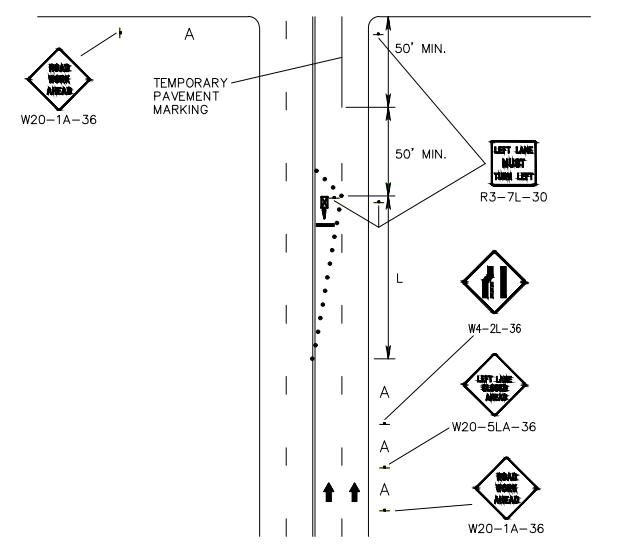
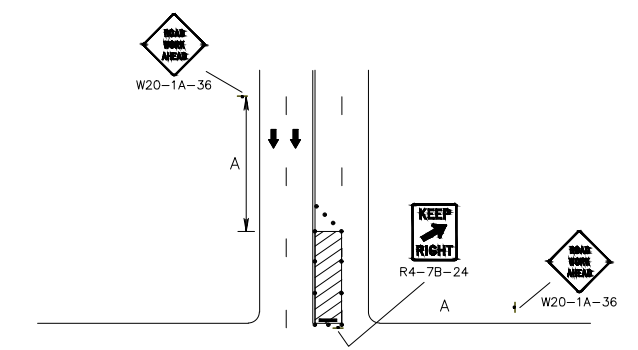

LANE CLOSED NEAR INTERSECTION (LEFT LANE CLOSURE FORMING A TURNBAY)

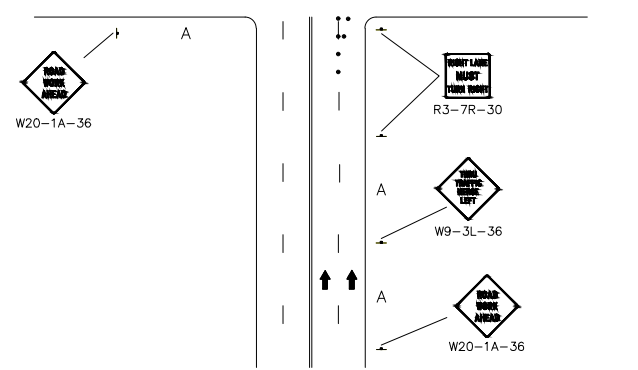
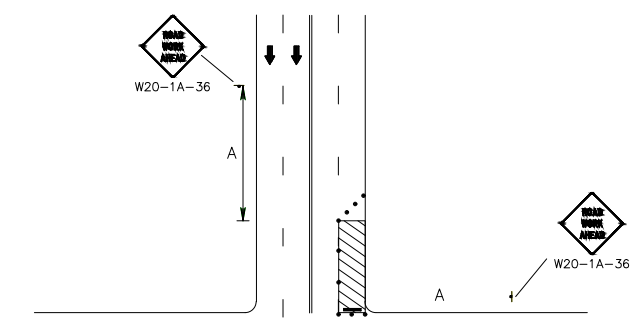

LANE CLOSED NEAR INTERSECTION (RIGHT LANE REMAINS OPEN)

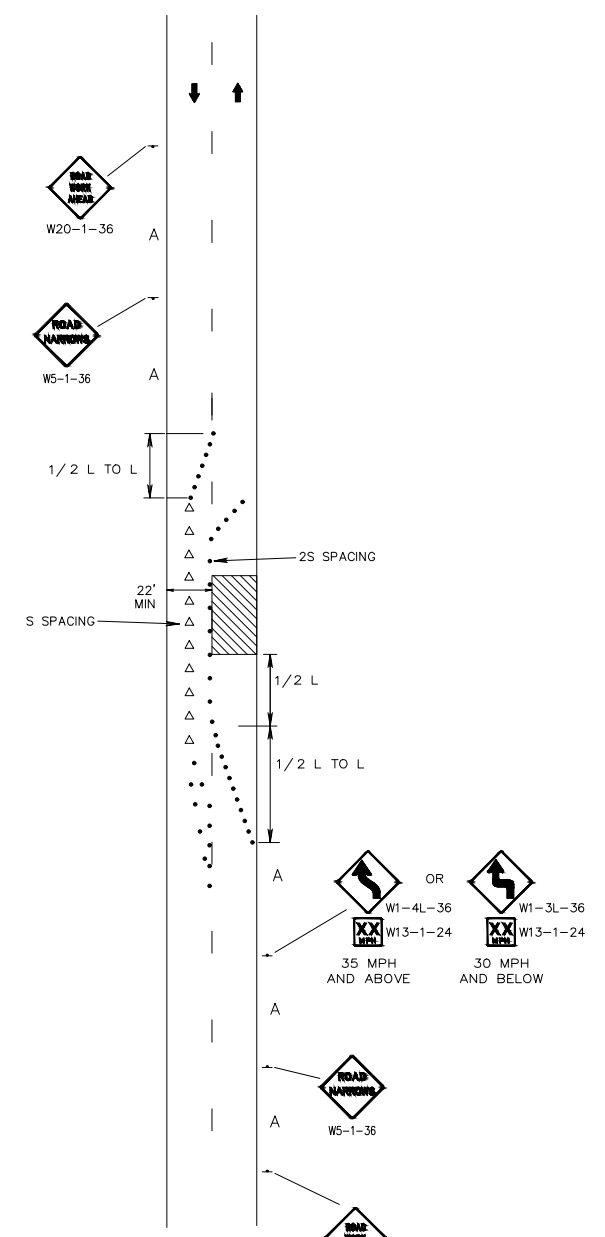

HEAD TO HEAD SPEEDS BELOW 40 MPH

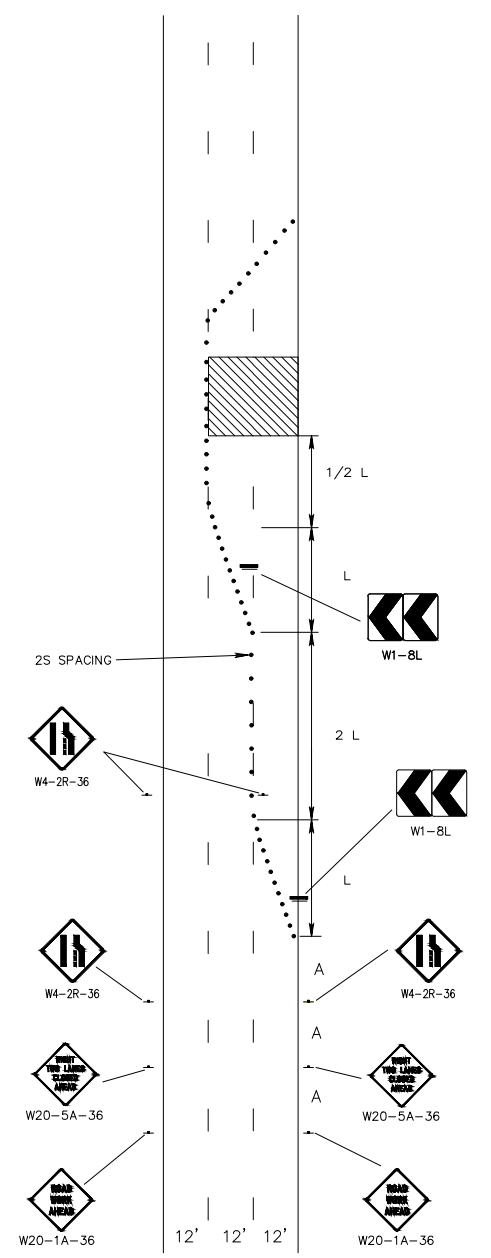

MULTIPLE LANE CLOSURE

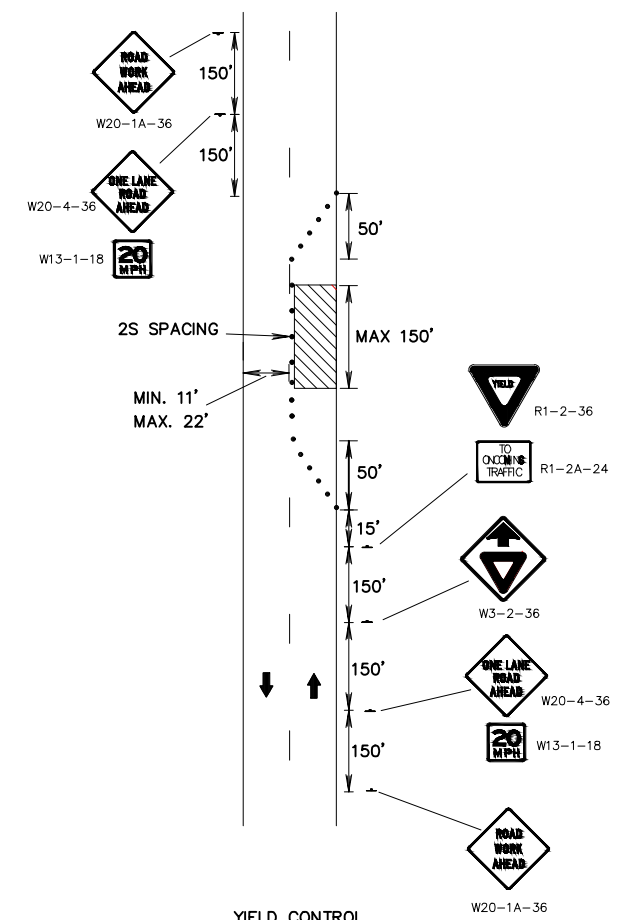

YIELD CONTROL USE FOR SPEED LIMITS OF 40 OR BELOW USE ON CITY STREETS ONLY

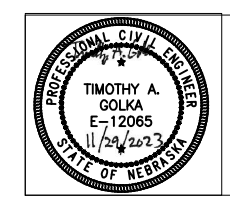

CITY OF GRAND ISLAND ENGINEERING DIVISION

TYPICAL TRAFFIC CONTROL PLAN

DESIGNED: 12/10 SG
REVIEWED: 11/28/2023

TYPICAL URBAN TRAFFIC CONTROL PLAN

TTC-2

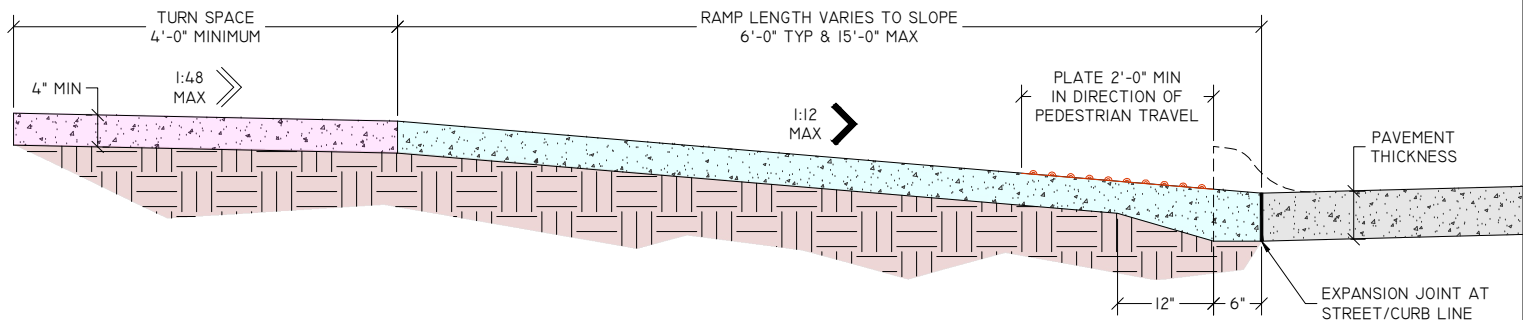
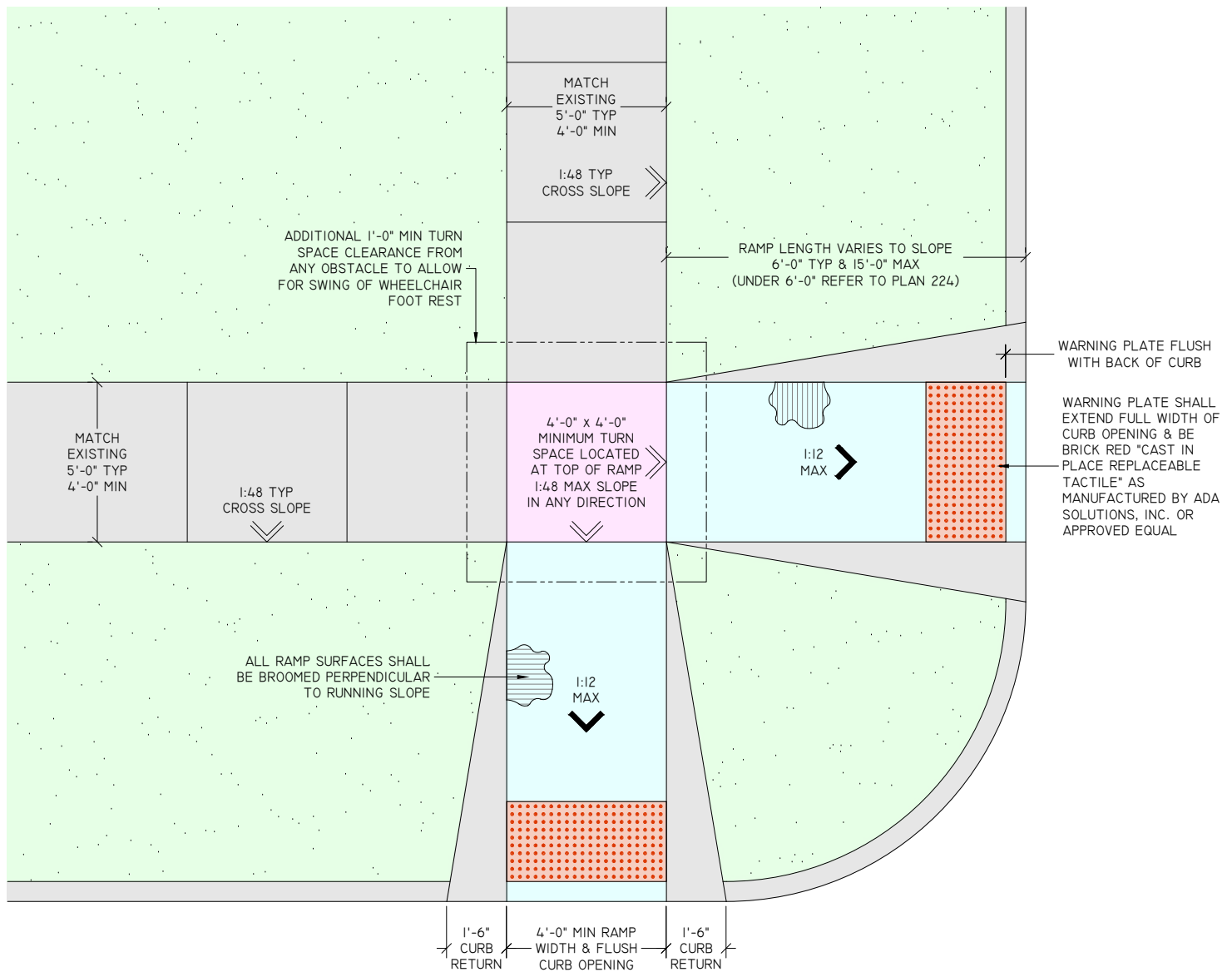

- NOTES:**
1. PERPENDICULAR CURB RAMPS STANDARD TO OFFSET SIDEWALKS.
 2. DETAILS PROVIDED HEREIN ARE TO BE USED AS A GUIDE IN COMBINATION WITH CURRENT ADA STANDARDS FOR ACCESSIBLE DESIGN, THE PUBLIC RIGHTS-OF-WAY ACCESSIBILITY GUIDELINES (PROWAG), AS WELL AS CITY OF GRAND ISLAND SIDEWALK STANDARD PLANS.
 3. CONTRACTOR SHOULD ACCOUNT FOR CONSTRUCTION TOLERANCES TO PREVENT EXCEEDING MAXIMUM SLOPES & TO ASSURE UNIFORM RAMP GRADE, FREE OF SAGS & SHORT GRADE CHANGES.
 4. CONSTRUCTION FORMS TO BE INSPECTED & APPROVED BY PUBLIC WORKS DEPARTMENT. RAMPS THAT DO NOT COMPLY WITH FEDERAL REGULATIONS WILL NOT BE ACCEPTED.
 5. ADDITIONAL CURB RAMP RESOURCES AVAILABLE ONLINE AT WWW.ADA.GOV & WWW.ACCESS-BOARD.GOV/PROWAG.

	<p align="center">PERPENDICULAR CURB RAMP</p> <p align="center">CITY STANDARD PLANS & SPECIFICATIONS GRAND ISLAND, NEBRASKA</p>	PLAN	225
		SHEET	1 OF 1
DRAWN BY: MWL		DATE: DEC 2017	
REVISED BY: MLS		DATE: AUG 2021	
APPROVED BY: KJK		DATE: SEPT 2021	

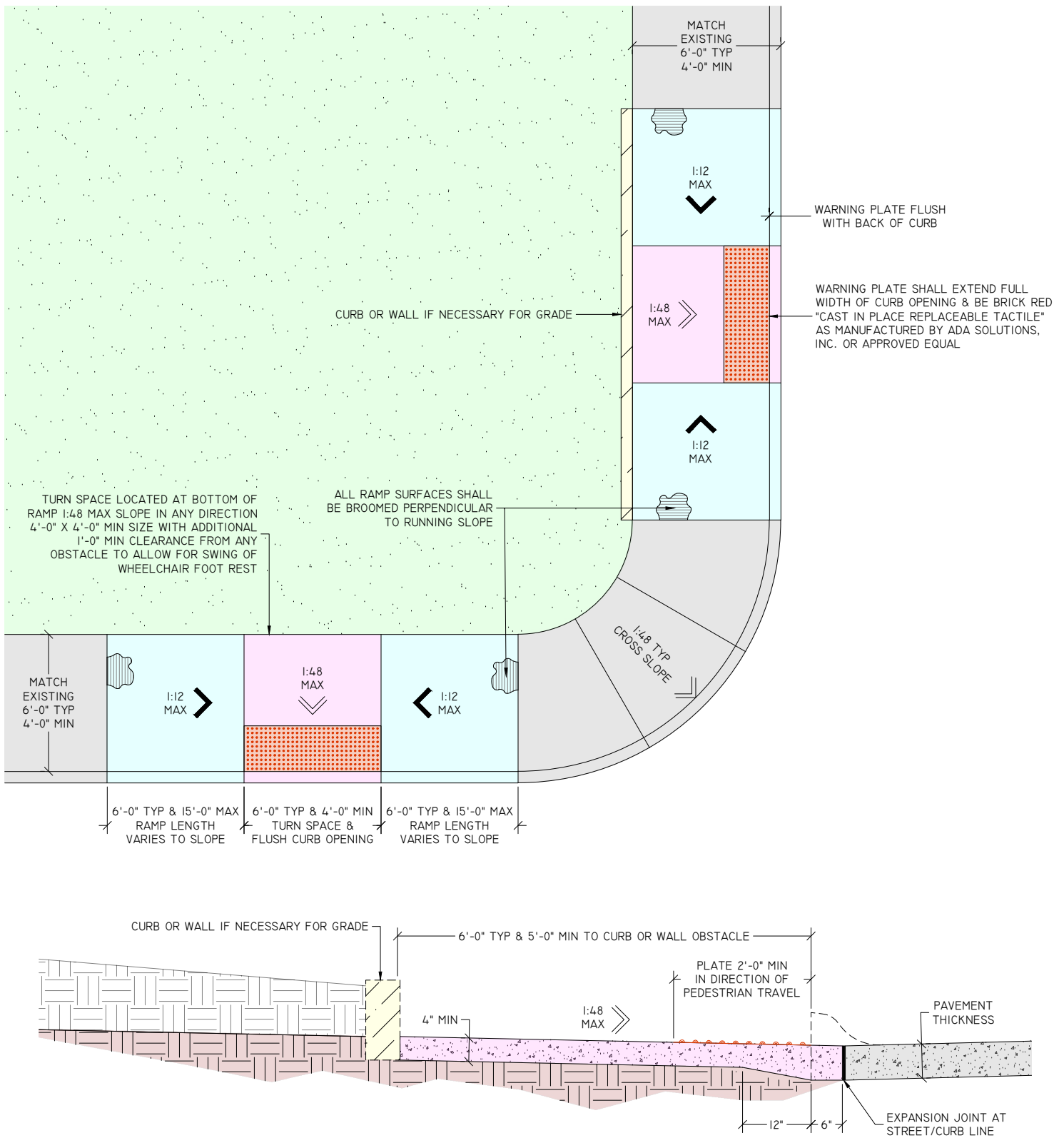

- NOTES:**
1. PARALLEL CURB RAMPS STANDARD TO CURBSIDE SIDEWALKS.
 2. DETAILS PROVIDED HEREIN ARE TO BE USED AS A GUIDE IN COMBINATION WITH CURRENT ADA STANDARDS FOR ACCESSIBLE DESIGN, THE PUBLIC RIGHTS-OF-WAY ACCESSIBILITY GUIDELINES (PROWAG), AS WELL AS CITY OF GRAND ISLAND SIDEWALK STANDARD PLANS.
 3. CONTRACTOR SHOULD ACCOUNT FOR CONSTRUCTION TOLERANCES TO PREVENT EXCEEDING MAXIMUM SLOPES & TO ASSURE UNIFORM RAMP GRADE, FREE OF SAGS & SHORT GRADE CHANGES.
 4. CONSTRUCTION FORMS TO BE INSPECTED & APPROVED BY PUBLIC WORKS DEPARTMENT. RAMPS THAT DO NOT COMPLY WITH FEDERAL REGULATIONS WILL NOT BE ACCEPTED.
 5. ADDITIONAL CURB RAMP RESOURCES AVAILABLE ONLINE AT WWW.ADA.GOV & WWW.ACCESS-BOARD.GOV/PROWAG.

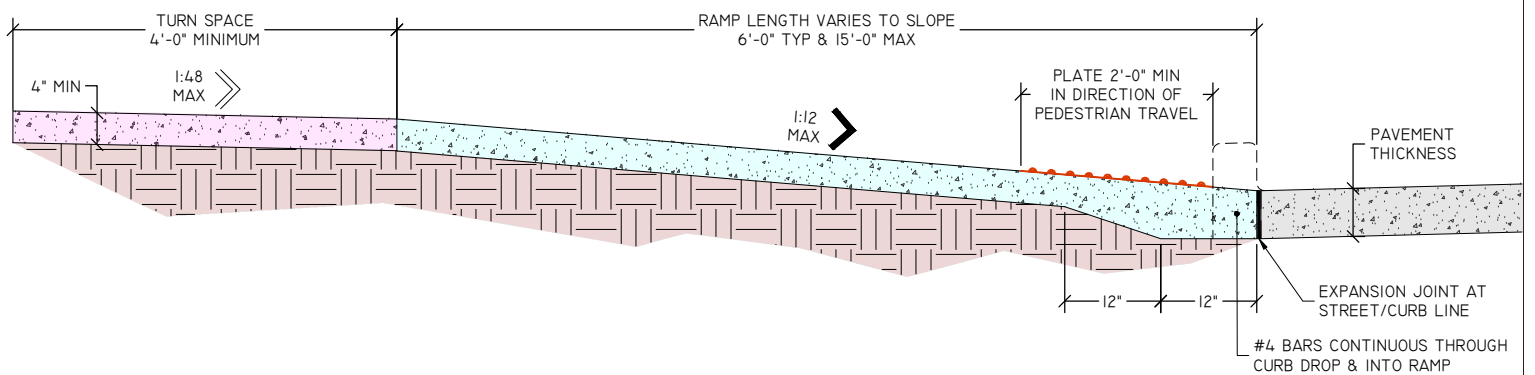
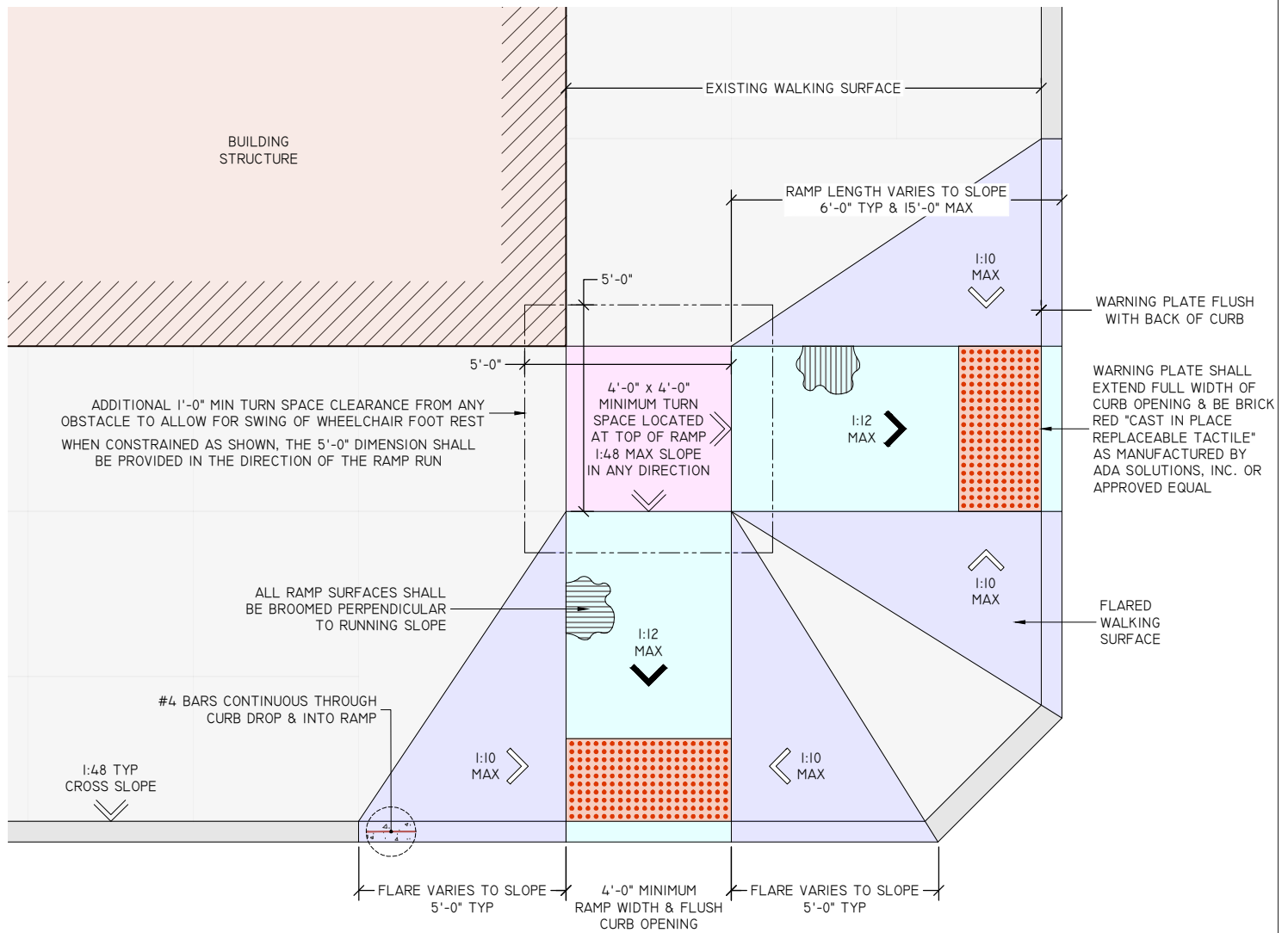

- NOTES:**
1. FLARED "WALKING SURFACE" CURB RAMPS STANDARD TO DOWNTOWN AREAS & WHEN SET WITHIN PEDESTRIAN CIRCULATION PATHS.
 2. DETAILS PROVIDED HEREIN ARE TO BE USED AS A GUIDE IN COMBINATION WITH CURRENT ADA STANDARDS FOR ACCESSIBLE DESIGN, THE PUBLIC RIGHTS-OF-WAY ACCESSIBILITY GUIDELINES (PROWAG), AS WELL AS CITY OF GRAND ISLAND SIDEWALK STANDARD PLANS.
 3. CONTRACTOR SHOULD ACCOUNT FOR CONSTRUCTION TOLERANCES TO PREVENT EXCEEDING MAXIMUM SLOPES & TO ASSURE UNIFORM RAMP GRADE, FREE OF SAGS & SHORT GRADE CHANGES.
 4. CONSTRUCTION FORMS TO BE INSPECTED & APPROVED BY PUBLIC WORKS DEPARTMENT. RAMPS THAT DO NOT COMPLY WITH FEDERAL REGULATIONS WILL NOT BE ACCEPTED.
 5. ADDITIONAL CURB RAMP RESOURCES AVAILABLE ONLINE AT WWW.ADA.GOV & WWW.ACCESS-BOARD.GOV/PROWAG.

	FLARED "WALKING SURFACE" CURB RAMP		PLAN	227
			SHEET	1 OF 1
CITY STANDARD PLANS & SPECIFICATIONS GRAND ISLAND, NEBRASKA		DRAWN BY:	MWL	DATE: DEC 2017
		REVISED BY:	MLS	DATE: AUG 2021
		APPROVED BY:	KJK	DATE: SEPT 2021

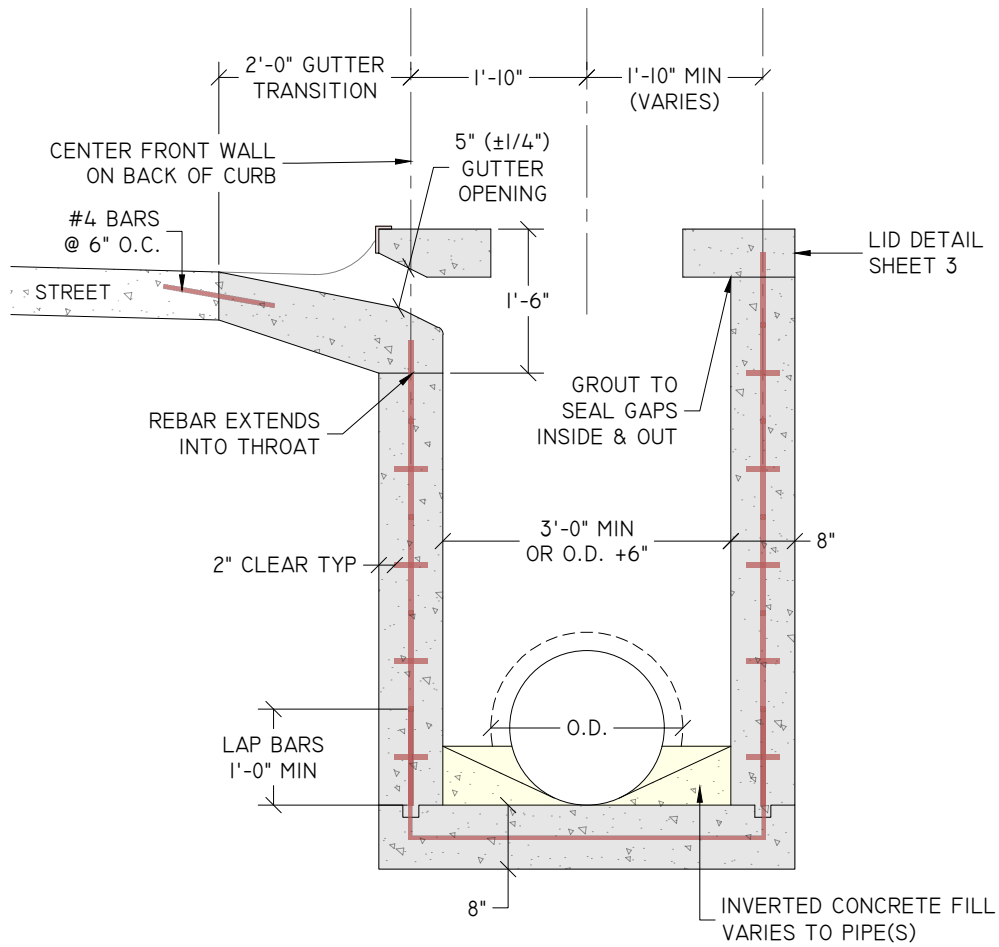

INLET TO STREET SECTION VIEW

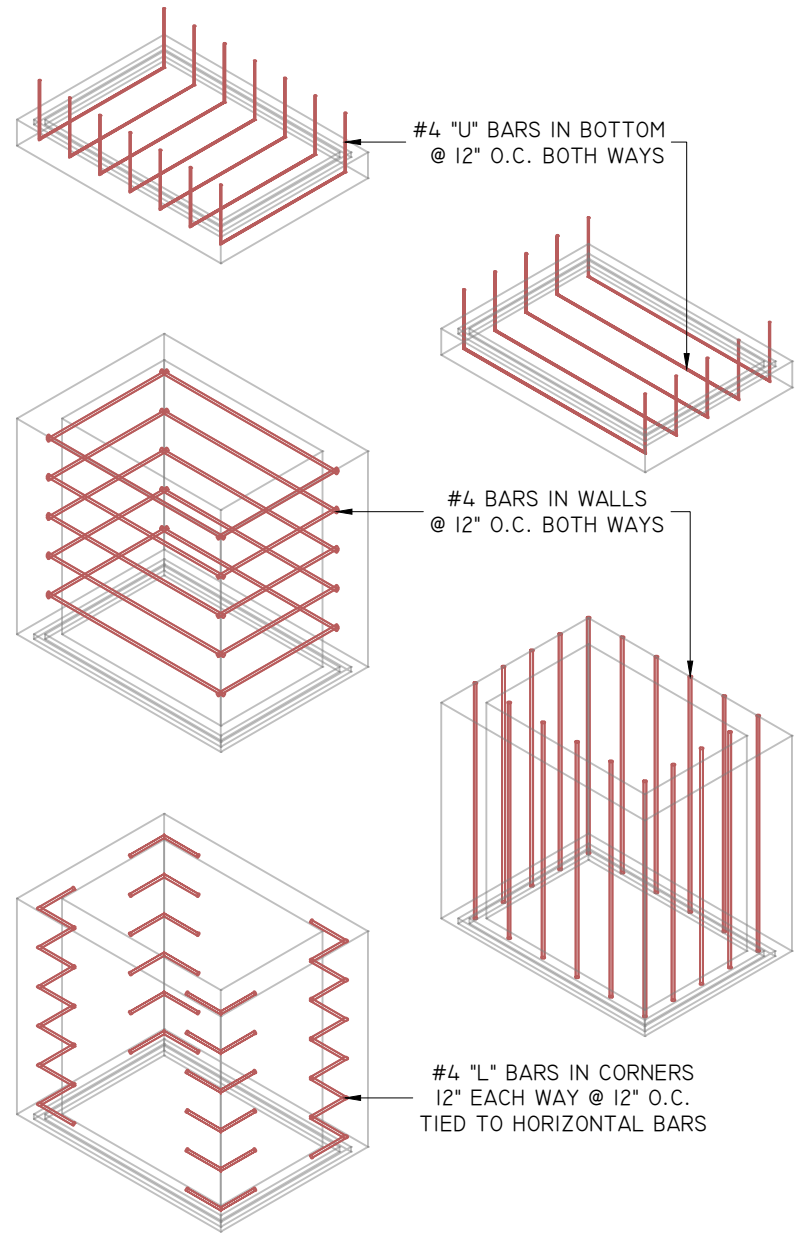

INLET REBAR LOCATION DETAIL

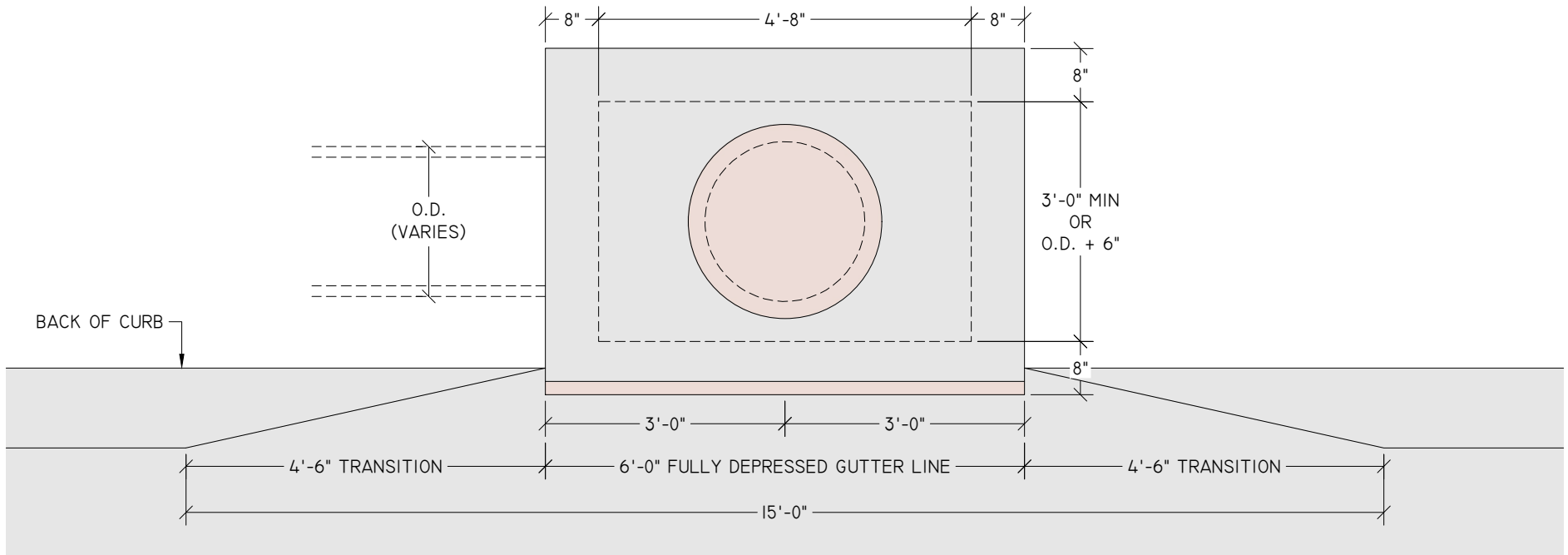

INLET PLAN VIEW

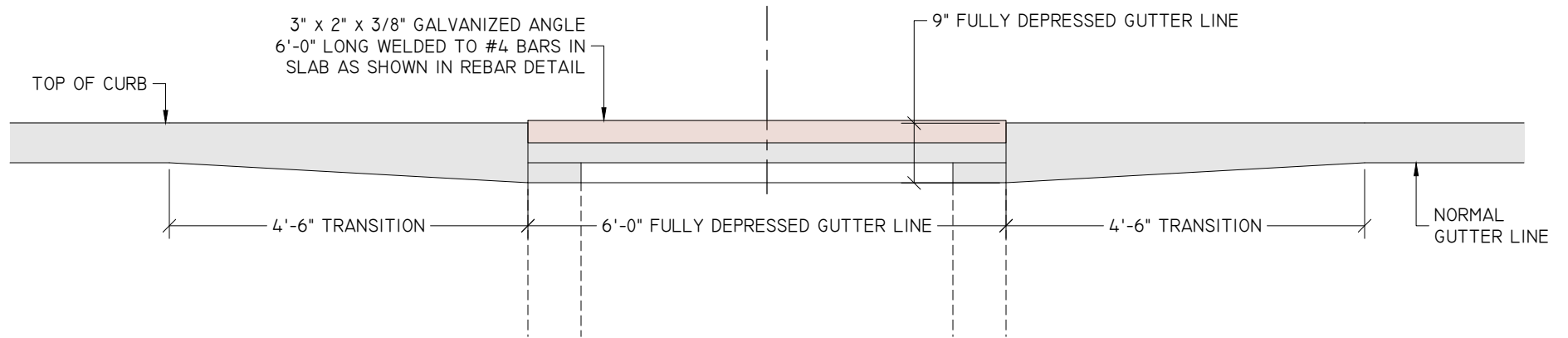

DEPRESSED GUTTER PROFILE VIEW

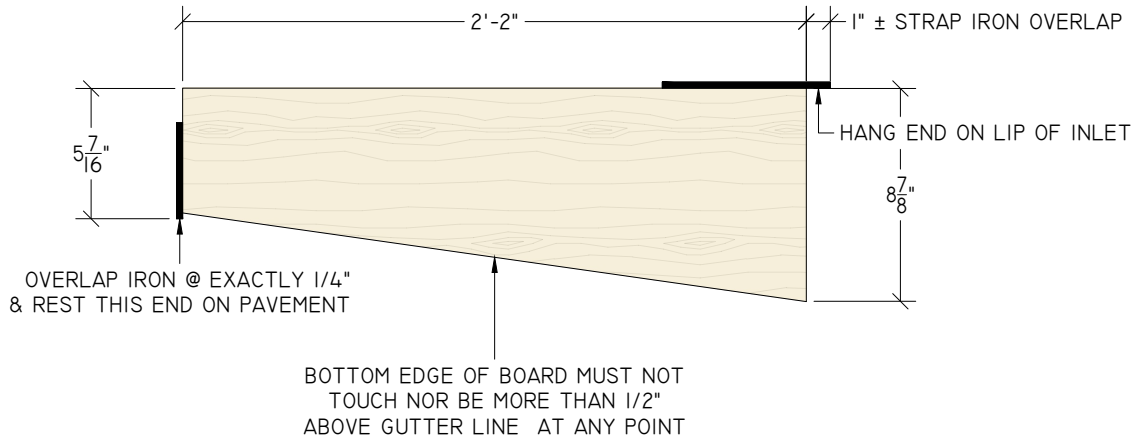

AUTOMATIC GUTTER LINE REJECTOR

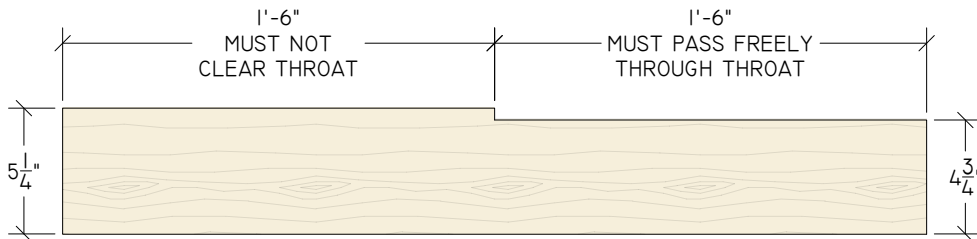

AUTOMATIC THROAT REJECTOR

NOTES:

- BOARDS SHOWN ARE TO BE CONSTRUCTED OF SUITABLE MATERIAL & ARE FOR USE WHILE CONCRETE IS STILL WORKABLE

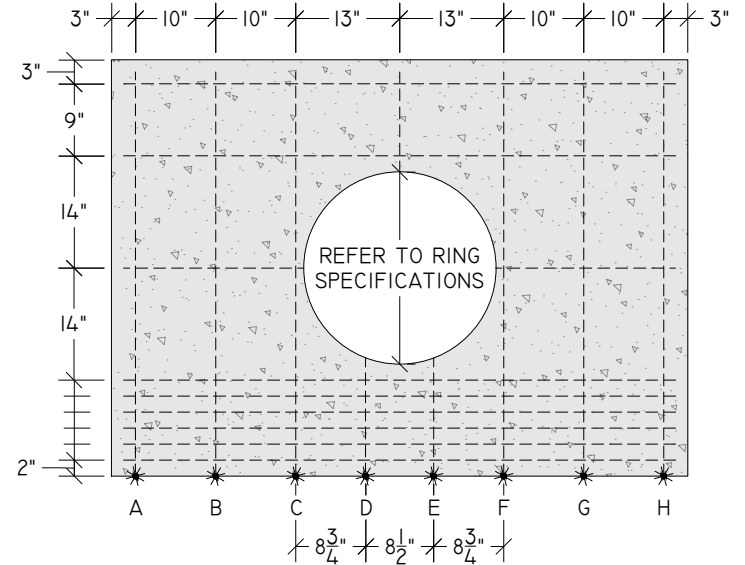
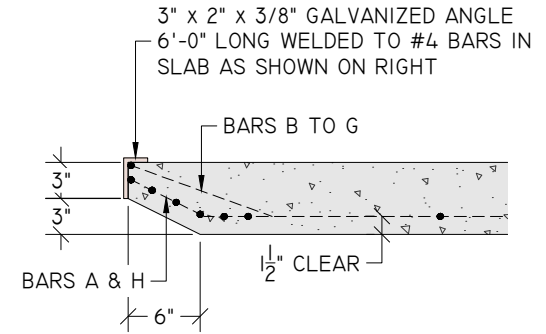

- USE #4 BARS
 * INDICATES LOCATION OF GALVANIZED ANGLE WELDS TO REBAR

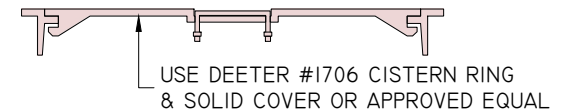

USE DEETER #1706 CISTERN RING & SOLID COVER OR APPROVED EQUAL

CONCRETE INLET LID & REBAR DETAIL

