



ADVERTISEMENT FOR BIDS  
FOR  
**Ten (10) Transmission Differential Relays**

Sealed bids will be received at the **Office of the City Clerk, 100 East First Street, Grand Island, NE 68801, until 2:00 pm. (Local Time), October 13, 2011** for furnishing Ten (10) Transmission Differential Relays, FOB the City of Grand Island. Quotes will be publicly opened at this time at the Office of the City Clerk, 100 East First Street, Grand Island, NE. Bids received after the specified time will be returned unopened to sender.

Specifications are on file in the office of the Purchasing Division. Bids shall be submitted on forms that will be furnished by the City.

Each bidder shall submit with their bid a certified check, cashiers check, or bid bond payable to the City Treasurer in an amount not less than five percent (5%) of the bid price which shall guarantee good faith on the part of the bidder and the entering into a contract within 14 days, at the bid price, if accepted by the City. **Your certified check, cashiers check or bid bond must be submitted in a separate envelope attached to the outside of the envelope containing the bid.** Each envelope must be clearly marked indicating its contents. Failure to submit the necessary qualifying information in clearly marked and separate envelopes will result in your bid not being opened or considered. Bid bonds must be issued by surety companies authorized to do business in the State of Nebraska.

Bids will be evaluated by the purchaser based on price, delivery, quality, and adherence to specifications. Each bidder shall supply four (4) copies of equipment specifications. The Purchaser reserves the right to reject any or all bids, to waive technicalities, and to accept whichever bid that may be in the best interest of the City.

No Company may withdraw its bid for a period of 30 days after date of bid opening.

RaNae Edwards,  
City Clerk

Issue Date: \_\_\_\_\_

**GENERAL SPECIFICATIONS AND BID SHEET  
FOR  
TEN (10) TRANSMISSION DIFFERENTIAL RELAYS  
CITY OF GRAND ISLAND, NEBRASKA**

Sealed bids will be **received at the office of the City Clerk**, 100 East First St., Grand Island, NE 68801 or P. O. Box 1968, Grand Island, Nebraska, until 2:00 pm (Local Time) on October 13<sup>th</sup>, 2011, for furnishing Ten (10) Transmission Differential Relays as specified in these bidding documents, FOB Grand Island, NE.

**Exceptions to Specifications** - Any bidder who has exceptions to any specifications and requirements listed in the bidding documents must so state in the space provided below. Exceptions should also be noted in the blanks provided in the detailed specifications. It is the bidder's responsibility to clearly outline any exceptions. Failure by bidder to outline exceptions will require the successful bidder to comply with the specifications.

**Exceptions to specifications:**

---

---

---

Attached are detailed minimum specifications. The following general specifications also apply to this bid.

<b>Bid Bond</b>	Each bidder shall submit with their bid a certified check, cashiers check or bid bond payable to the City Treasurer in an amount not less than five percent (5%) of the bid price which shall guarantee good faith on the part of the bidder and the entering into a contract within 14 days, at the bid price, if accepted by the City. <b><u>Your certified check, cashiers check or bid bond must be submitted in a separate envelope attached to the outside of the envelope containing the bid.</u></b> Each envelope must be clearly marked indicating its contents. Failure to submit the necessary qualifying information in clearly marked and separate envelopes will result in your bid not being opened or considered. Bid bonds must be issued by surety companies authorized to do business in the State of Nebraska.
<b>Bid Submittal</b>	All envelopes submitted by Bidder must state "Transmission Differential Relays, Opening October 13 <sup>th</sup> " on the face of envelope.
<b>Manuals</b>	Refer to specifications.
<b>Warranty</b>	The equipment shall carry the standard warranty (no less than one year); bidder should include warranty details with the bid; failure to comply may cause bid rejection.
<b>Descriptive Literature</b>	The bidder shall attach hereto, and it shall be made part of this bid, regularly printed literature as published by the factory which sets out and fully describes the equipment to be furnished in the bid. This literature or other supplemental information shall clearly indicate compliance with each and every item of these Specifications. Failure to indicate compliance may be cause for rejection of bid.

**Optional Equipment** The general and detailed specifications are the minimum requirements. Bidder may include optional equipment if desired. Optional equipment should be noted as such.

**OSHA & ANSI Requirements** In addition to other specified requirements, the equipment shall meet all current Occupational Safety and Health Administration and American National Standards Institute requirement specifications.

**Award** Upon approval by the Grand Island City Council, a City of Grand Island Utilities Department Purchase Order shall be issued to the successful bidder.

**Delivery** Equipment is to be delivered from assembly point to Grand Island, Nebraska, by commercial freight or truck. Delivery will be to Phelps Control Center, 700 E Bischeld St., Grand Island, NE 68801. The winning bidder shall contact Travis Spiehs at (308) 385-5462 when the equipment has shipped out. Delivery time shall be between 8:00 and 11:30 am or 1:30 and 4:30 pm CST Monday through Friday. The City of Grand Island is not responsible for delivery delays due to failure to provide delivery notice.

**Delivery Date** Each bidder shall state in his bid a realistic delivery date for this equipment. Award winning bidder must deliver within quoted delivery time.

**Inspection** The equipment must be new, the latest make or model, unless otherwise specified. Prior to approving the invoice for payment, the City reserves the right to thoroughly inspect and test the equipment to confirm compliance with specifications. Any equipment which does not meet the City's requirements will be returned at vendor's expense for correction. All specified data, diagrams and manuals must be received prior to approval of invoice.

**Payment** The invoice will be paid after approval at the next regularly scheduled Council meeting occurring after departmental approval of invoice; the City Council typically meets the second and fourth Tuesday of each month. Invoices must be received well in advance of Council date to allow evaluation and processing time.

**Fair Employment Practices** - Each bidder agrees that he/she will not discriminate against any employee or applicant for employment because of age, race, color, religious creed, ancestry, handicap, sex or political affiliation.

**Data Privacy** - Bidder agrees to abide by all applicable Local, State, and Federal laws and regulations concerning the handling and disclosure of private and confidential information concerning individuals and corporations as to inventions, patents and patent rights. The bidder agrees to hold the City harmless from any claims resulting from the bidder's unlawful disclosure or use of private or confidential information.

**Independent Price Determination** - By signing and submitting bid, the bidder certifies that: the prices in the bid have been arrived at independently, without consultation, communication or agreement, for the purpose of restricting competition, as to any matter relating to such prices with any other bidder or with any competitor.

**Clarification of Specification Documents** - Vendors shall promptly notify Travis Burdett at (308) 385-5466 of any ambiguity, inconsistency or error that they may discover upon examination of the specifications.

Interpretations, corrections and changes made to the specifications will be made by written addenda. Oral interpretations or changes to the specifications made in any other manner will not be binding on the City; and bidders shall not rely upon such interpretations or changes.

**Gratuities and Kickbacks** - City Code states that it is unethical for any person to offer, give, or agree to give any City employee or former City employee, or for any City employee or former City employee to solicit, demand, accept, or agree to accept from another person, a gratuity or an offer of employment in connection with any decision, approval, disapproval, recommendation, or preparation of any part of a program requirement or a purchase request, influencing the content of any specification or procurement standard, rendering of advice, investigation, auditing, or in any other advisory capacity in any proceeding or application, request for ruling, determination, claim or controversy, or other particular matter, pertaining to any program requirement or a contract or subcontract, or to any solicitation or proposal therefore. It shall be unethical for any payment, gratuity, or offer of employment to be made by or on behalf of a subcontractor under a contract to the prime contractor or higher tier subcontractor or any person associated there within, as an inducement for the award of a subcontract or order.

**BID FORM**  
**CITY OF GRAND ISLAND, NEBRASKA**  
(All bids must be submitted on this form)

TO THE CITY COUNCIL, CITY OF GRAND ISLAND, GRAND ISLAND, NE

The Undersigned bidder, having examined all specifications and other bidding documents, and all addenda thereto, and being acquainted with and fully understanding all conditions relative to the furnishing of the specified equipment to the City of Grand Island, NE hereby proposes to furnish and deliver such equipment FOB Grand Island, NE, at the following price:

<u>ITEM DESCRIPTION:</u>	<u>COST</u>
Total Base Bid:	\$ _____
7% Nebraska Sales Tax	\$ _____
<b>TOTAL BID PRICE *</b>	<b>\$ _____</b>

\* The City of Grand Island, Utilities Department **does** pay sales tax. If bidder fails to include sales tax in the bid price or takes exception to including sales tax in the bid price, the City will add a 7% figure to the bid price for evaluation purposes; however, the City will only pay actual sales tax due.

If awarded the contract, the undersigned bidder agrees to deliver the specified equipment within \_\_\_\_\_ days from date of order.

To allow for City processing time, terms shall be Net 30.

Bidder acknowledges receipt of Addendum Number(s) \_\_\_\_\_ and has considered addendum information in bid preparation.

Attached to the bid is all supplementary information requested in the bidding documents.

\_\_\_\_\_  
Bidder Company Name Date

\_\_\_\_\_  
Company Address

\_\_\_\_\_  
Name of Person Completing Bid (please print)/Signature

Telephone #: \_\_\_\_\_ Fax #: \_\_\_\_\_

CITY OF GRAND ISLAND RESERVES THE RIGHT TO ACCEPT OR REJECT ANY OR ALL BIDS.

**Note: Any exceptions to specifications must be noted in the space provided on Page 1 of General Specifications.**

# **Detailed Specifications for Ten (10) Transmission Differential Relays**

## **Scope**

The Grand Island Electric Department is soliciting bids for the purchase of ten (10) digital line differential relays to be used as replacements for electro-mechanical relays currently in use on the Grand Island 115 kV transmission loop. Six relays will be used to upgrade three line segments of the 115 kV transmission loop while two will be installed in a future substation and two for spares.

## **Overview**

The Grand Island Electric Department is a municipally owned electric utility, with a summer peak demand in excess of 165 MW. The Electric Department serves its load with local generation and distribution substations on a 115 kV transmission loop. A single-line drawing of the electric system Power Supply is included with these specifications. The north half of the 115 kV transmission loop was upgraded to digital relaying in 2001 with the addition of substations E and F. The south half of the loop continues to utilize electro-mechanical relaying. It is the desire of the Grand Island Electric Department to upgrade the south half of the loop in order to provide increased reliability and functionality.

## **Physical Dimensions and Configurations**

All ten relays will be horizontally mounted in a 19 inch rack. Dimensions of the relays shall be provided with the bid.

## **Power Supply**

The relays shall operate on 125V DC power supply. The manufacturer shall state the voltage range of power supply.

## **Analog Inputs**

The relay must accept a current transformer (CT) ratio range of 100/5 to 3000/5 and must be software selectable. The relay should be able to accept 15 A continuous, 300 A for one second. The manufacturer shall state the range of CT ratios the relay can accept.

The potential transformer (PT) input to the relay (if required) will be 67VL-N, three-phase, four-wire, however, in the event the relay be used with another PT ratio, the relay must be able to be software selectable to accept a range of PT ratios from 1 to 6000. The relay should be able to accept 200 VL-N continuous, 400 Vac for ten seconds. The manufacturer shall state the range of PT ratios the relay can accept.

The protection CT and PT input frequency will be 60 Hz.

## **Programmable Control Inputs and Outputs**

### **Control Inputs**

The relay's wet control input voltage is 125V DC. The relay will have a minimum of 12 programmable inputs for various logical control and protection functions.

### **Control Output Contacts**

The relay will have a minimum of 8 programmable output contacts in addition to the standard breaker close and open contacts for two breakers. A relay alarm output should also be provided to signal loss of protection.

The output contacts must have the following ratings:

- 6 A continuous carry
- 30 A make per IEEE C37.90 : 1989
- 30 A for one second
- Breaking Capacity of 10 A DC for trip contacts

## **Ratings and Tolerances**

The relays must include Surge Withstand Capabilities and fast transient tests per ANSI C37.90.1 and IEC 255-22-1 class III and 255-22-4 class IV for all connections except communications or AUX ports

The relay must include EMI ratings per ANSI C37.90.2

The relays must be able to operate in a range of -20C to +65C (-4F to 150F).

## **Protective Functions**

### **Current Differential**

The relays shall monitor and communicate power characteristics to determine differential faults over the protected transmission line. The relays shall compare phase and sequence components from each line terminal in order to determine fault conditions. The relays shall be capable of differentiating between fault conditions and line charging currents or high flow conditions. Communications shall be accomplished with an RS-422 communication path to another identical relay at another substation. The relay must interface with an RFL IMUX-2000 multiplexer using a 37 pin port. The pertinent portion of the IMUX manual is included with these specifications. Additionally, relays should also support direct fiber connections or G.703 standard connections for future expansion.

### **Reclosing**

Relays should include pre-defined one, two, three and four shot reclosers with instantaneous and user adjustable time delayed reclose shots. The conditions under which the recloser is active must be user selectable, for example, active during overcurrent conditions but inactive during underfrequency conditions.

### **Overcurrent**

Relays should include an instantaneous overcurrent element and a time overcurrent element for phase and ground connections. Time curves should include inverse, very inverse, extremely inverse, and definite time. The pickup setting should be adjustable over the range of the rated current input.

### **Under/Overvoltage**

Relays should include under and overvoltage protection on the attached elements for both phase and neutral. These elements should be time dependent.

### **Bus Stub Protection**

When used in breaker and a half configurations, the relays shall be capable of bus stub protection. This shall disable communications with the opposite end of the line and provide protection of the local substation components only.

### **Metering**

The relay should be capable of metering voltage (phasors, true RMS values, symmetrical components), current (phasors, symmetrical components, true RMS values), real, reactive and apparent power, power factor, and frequency. The relay should include an option to log any of these values into memory with a user defined trigger and sampling rate.



The relay shall be able to display any desired values on a front panel in real time as programmed.

## **Fault Recording**

The relay shall have the capability to store raw sampled transient data with programmable sampling rate (at least 30 samples per cycle) with a provision for minimum of 36 records to store/monitor information about any physical I/O point or internal digital and analog quantities.

## **Communications**

In addition to the high speed differential communication, the relay shall provide at minimum one serial port on the front and rear of the relay. Relays should support protocols DNP3.0, Modbus RTU and Modbus TCP/IP. The relay clock shall be capable of being synchronized with an IRIG-B signal to allow synchronism with other connected devices. The relay shall allow for SNTP network-based time synchronization.

## **Additional Materials and Services**

### **Communication Cables**

Two communication cables will be provided to allow communication between the relay and a USB port on a computer. In addition, one 37 pin cable per relay should be provided for communication between the relay and the IMUX-2000 multiplexer.

### **Software**

Two CD-ROMs containing the windows-based communications software will be provided. Any necessary drivers and licenses required for communications and programming shall also be provided.

### **Instruction Manuals**

Seven hardcopies of the relay instruction manual will be provided. Two electronic copies of the relay instruction manual will be provided. This electronic copy may be included on the above-mentioned CD-ROM.

**Training**

The vendor and/or manufacturer shall supply one day of on-site training to provide hands-on instructions on the use and features of the relays. This visit will be independent from any visits that may be required to resolve problems associated with installation.

**Configuration Upon Receipt**

The relays shall come fully assembled, tested and calibrated.

**Delivery**

The bidder shall state in their bid the approximate delivery time for their product. Delivery time shall be considered when evaluating the bids received.

**References**

The bidder shall provide a list of five (5) U.S. based references that are currently using the product. Bid evaluation shall include reference checks.

**Exceptions**

---

---

---

---

---

---

---

---

---

---

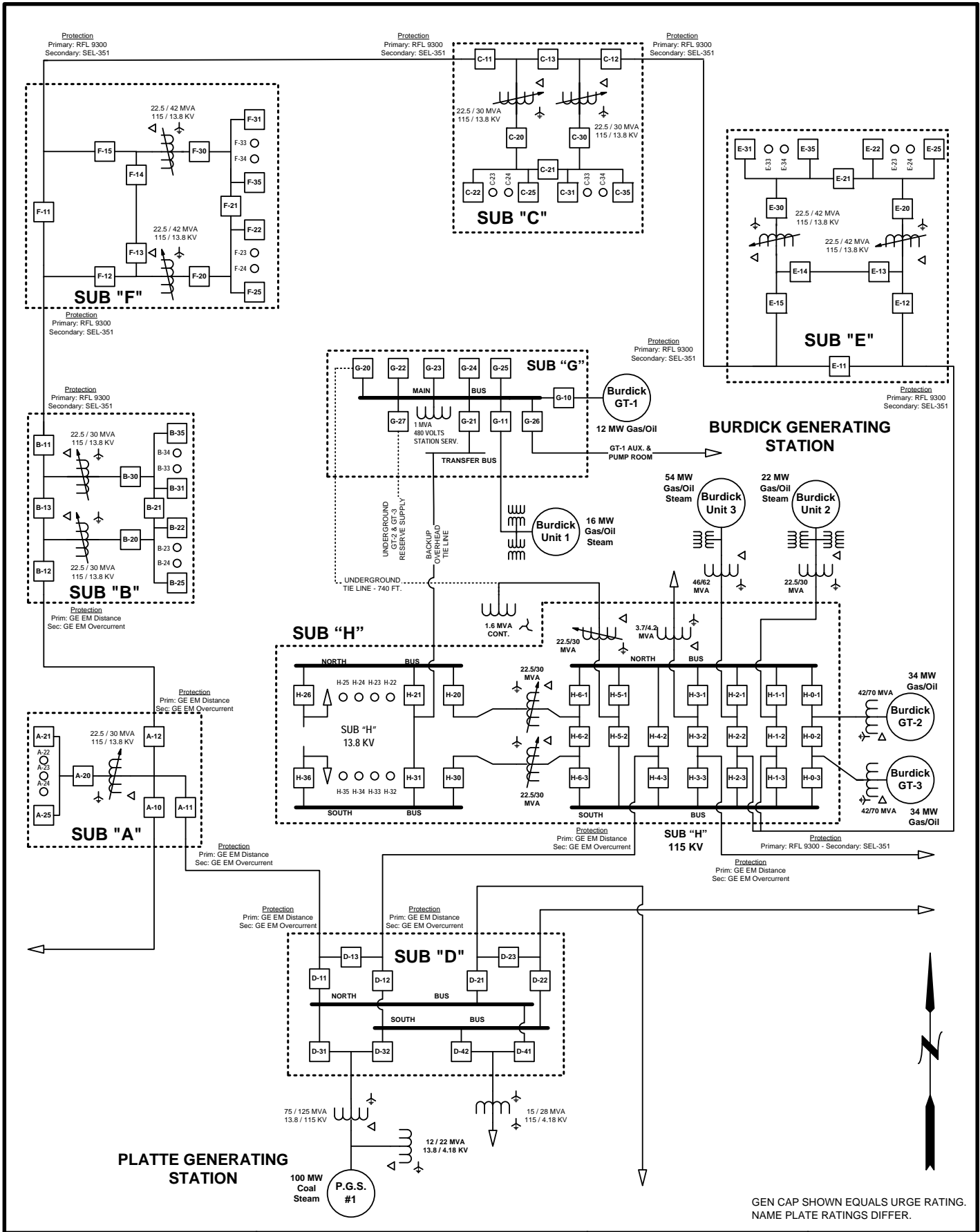

<p><b>CITY OF GRAND ISLAND</b>  <b>UTILITIES DEPARTMENT</b></p>	<p><i>POWER SUPPLY</i></p>	<p><b>DRN. BY:</b> H.M.G./J.L.M.</p>	<p><b>DWG. NO.</b>  <b>S-56-11</b></p>
		<p><b>DATE :</b> 01/28/99</p>	
		<p><b>SCALE :</b> NONE</p>	
		<p><b>SHEET :</b> 1 OF 13</p>	
		<p>Rev. 4/12/2006</p>	

## 16.2 DS-562I

**RFL Electronics Inc.**

# INSTRUCTION DATA

## **Synchronous Data Module**

**For RFL IMUX 2000 Intelligent T1/E1 Multiplexers  
RFL DS-562I (RS-449, CCITT V.35, G.703, X.21  
Or Short Haul Optical Fiber Interface)**

### **DESCRIPTION**

The RFL DS-562I Synchronous Data Module provides RFL IMUX 2000 T1/E1 Multiplexers with synchronous full-duplex data communications at either 56 Kbps or 64 Kbps. The RFL DS-562I operates in terminal or drop and insert systems over T1/E1 carrier lines and uses RS-449/422, CCITT V.35, G.703, X.21/V.11, or short haul optical fiber interfaces. The RFL DS-562I communicates with older RFL DS-562B modules and occupies only one shelf location.

This module communicates using a single bi-directional time slot. When communicating at 56 Kbps the communication protocol includes provisions for programmable addressing to prevent DS0 misconnections. One of 63 addresses is selectable locally using DIP switches or remotely using software. LEDs indicate when the addressing feature is enabled, and when the DS-562I has established valid communications with the appropriate DS-562I. As an option the received data may be squelched during loss of valid address. This option can be selected locally using DIP switches or remotely using software.

When using an RS-449 interface, the RFL DS-562I allows the selection of local loopback or remote loopback functions. Local equipment loopback takes the data coming in on the 56/64 Kbps I/O port and sends it back out on the same I/O port. Local payload loopback (also called "remote loopback") echoes the T1/E1 data back to the source. The loopbacks may be enabled remotely via software or locally by either a front accessible toggle switch, or when using the RS-449 interface, via pins on the rear panel connector. The local loopback commands will override any remote (software) loopback commands. The board contains two LEDs to indicate when either type is enabled.

The RFL DS-562I may be operated as a DCE or DTE. In DTE mode the connected equipment supplies the transmit clock. The externally supplied clock must be synchronous with the T1/E1 carrier. The card supports data, clock, RTS, and CTS signals at the user connector. The CTS is normally a copy of the RTS signal, but as an option can be delayed by approximately 8 microseconds.

### **NOTE**

Channel addressing cannot be used on G.703 interfaces since G.703 only operates at 64 Kbps.

## SPECIFICATIONS

As of the date this Instruction Data Sheet was published, the following specifications apply to all RFL DS-562I Synchronous Data Modules, except as noted. Because all RFL products undergo constant refinement and improvement, these specifications are subject to change without notice.

### **Input Voltage Differential:**

RS-449 (EIA-422) Interface: 0.2 to 6 volts  
CCITT V.35 Interface: 0.2 to 6 volts  
G.703 Interface: 0.35 to 1 volt  
X.21 (Rec. V.11) Interface: 0.3 to 6.0 volts

### **Input Impedance:**

RS-449 (EIA-422) Interface: 90 ohms to 150 ohms nominal  
CCITT V.35 Interface: 100 ohms nominal  
G.703 Interface: 120 ohms nominal  
X.21 (Rec. V.11) Interface: 575 ohms nominal

### **Output Voltage Differential:**

RS-449 (EIA-422) Interface: 2.0 to 4.0 volts  
CCITT V.35 Interface: 0.44 to 0.66 volts  
G.703 Interface: 0.95 to 1.05 volts  
X.21 (Rec. V.11) Interface: 2.0 to 4.0 volts

### **Output Impedance:**

RS-449 (EIA-422) Interface: Less than 100 ohms nominal  
CCITT V.35 Interface: 100 ohms nominal  
G.703 Interface: 300 ohms nominal  
X.21 (Rec. V.11) Interface: Less than 100 ohms nominal

### **Distortion Tolerance:**

Send Timing Jitter:  $\pm 1\%$   
Receive Timing Jitter:  $\pm 2\%$   
Send Data:  $\pm 25\%$  of sampling interval.  
Receive Data:  $\pm 25\%$  of sampling interval.

### **Handshaking Delay:**

Switched: 8 microseconds (approx.)  
Unswitched: Zero delay.

**Local Loopback (switched):** Equivalent to CCITT V.54 Loop 3.

**Remote Loopback (switched):** Equivalent to CCITT V.54 Loop 2.

**External Cabling:**

Maximum Length:

RS-449, V.35, X.21: 60m

G.703: 250m

Optical: up to 1 km

Cable type:

Shielded twisted

AWG 24 (minimum)

Multimode optical fiber

Connector:

RS-449 Interface: 37-pin male D-subminiature (DC-37P).

CCITT V.35 Interface: 37-pin male D-subminiature (DC-37P).

CCITT G.703 Interface: 25-pin male D-subminiature (DC-25P).

CCITT X.21 Interface: 15-pin male D-subminiature (DC-15P).

Optical fiber interface: Type ST

**Power Consumption:** 2 watts maximum**Operating temperature:** -20C to + 55 C (-4F to +131F)**Humidity:** 0 to 95 percent, non-condensing**Dimensions:**

Length: 9.8 in (24.8 cm)

Width: 0.6 in (1.5 cm)

Height: 4.5 in (11.4 cm)

**Weight:**

Net: 10 oz (0.28 kg)

Shipping: 1 lb (0.45 kg)

## INSTALLATION

Before the DS-562I module can be placed in service, it must be installed in a multiplexer shelf. Installation involves determining the module slot in the Main Shelf or Expansion Shelf where the module will be installed, inserting an I/O adapter module into the rear of the shelf behind the module slot, connecting all signal wiring to the I/O adapter module, checking the settings of all switches and jumpers, and inserting the module into the front of the shelf.

### NOTE

Power supply and time slot considerations may affect the installation of RFL DS-562I modules into an existing multiplexer shelf. Refer to the portions of your multiplexer operation manual covering “Channel Module Configuration Guidelines” and “Adding More Channel Modules To Existing Systems” for more information.

The following instructions are provided for installing RFL DS-562I modules into existing systems. If the module was included as part of a system, installation was done at the factory, otherwise, proceed as follows:

1. Carefully inspect the RFL DS-562I and its I/O adapter module for shipping damage.  
**If you suspect damage to the module or its Module Adapter, immediately contact RFL’s Customer Service Department at the number shown at the bottom of this page.**
2. Determine which module slot in the Main Shelf or Expansion Shelf the RFL DS-562I will be installed in.  
**The RFL DS-562I module occupies one module slot in the Main Shelf or Expansion Shelf. Refer to the “as supplied” drawings furnished with the equipment for more information.**
3. Determine which I/O Adapter Module will be used to make connections to the RFL DS-562I module.  
**Each RFL DS-562I module installed in an IMUX 2000 multiplexer requires an I/O Adapter Module. The I/O Adapter Module provides the appropriate connections for the desired interface.**

**There are six Module Adapters for the RFL DS-562I:**

<u>Module Adapter</u>	<u>Part Number</u>	<u>Interface Type</u>	<u>Socket</u>	<u>Figure</u>
MA-406IA	9547-16331	RS-449	37 pin D-subminiature (DC-37S)	1
MA-407I	9547-1750	G.703 contradirectional	25 pin D-subminiature (DC-25S)	2
MA-408I	9547-1755	G.703 codirectional	25 pin D-subminiature (DC-25S)	3
MA-409IA	9547-17271	V.35	37 pin D-subminiature (DC-37S)	4
MA-410I	9547-1760	X.21	15 pin D-subminiature (DC-15S)	5
MA-600	9547-600	Optical fiber	Type ST	7

**Make sure the I/O Module Adapter you are installing is the correct one for the desired application.**

4. Once the Adapter Module has been selected, set it for the following desired configuration as applicable:

**MA-406IA**

Select DCE or DTE mode by installing J2 jumpers

**MA-407I**

No configuration is required for this module.

**MA-408I**

No configuration is required for this module.

**MA-409IA**

Select DCE or DTE:

DCE: Set jumpers J1 to J9 to DCE

DTE: Set jumpers J1 to J9 to DTE

**MA-410I**

DCE: S1-1 to S1-4 (toward "DCE")

DTE: S1-1 to S1-4 (toward "DTE")

**MA-600**

No configuration is required for this module.

5. Insert the Adapter Module into the rear of the shelf directly behind the module slot where the DS-562I will be installed. Secure the module with the two screws provided.
6. Connect the Adapter Module to the user equipment using the connector pin assignments detailed in Tables 1, 2, 3, 4, or 5 as applicable.
7. Refer to Figure 6 for the location of switches on the DS-562I
8. On the DS-562I check the setting of toggle switch SW6.  
**SW6 controls the loopback, up to enable equipment loopback, down to enable payload loopback, or center for no loopback. Set SW6 to the center position.**
9. On the DS-562I check the setting of DIP switch SW7-1 through SW7-6.  
**SW7-1 through SW7-6 controls the modules SCB address. Set the switches to achieve the desired SCB address setting as shown in Table 7.**
10. On the DS-562I check the setting of DIP switch SW7-7.  
SW7-7 turns the DS-562I's service on or off. Down turns the service off (board disabled) up turns the service on (board enabled). Set the switch down.
11. On the DS-562I check the setting of DIP switch SW7-8.  
**SW7-8 sets the DS-562I for local or remote control. Down places the DS-562I in remote mode (settings obtained from the SCB), up sets the module for local mode (settings obtained from the DIP switches). Set the switch up.**



12. On the DS-562I check the setting of DIP switch SW1-1 through SW1-5.  
**SW1-1 through SW1-5 controls the modules transmit and receive timeslot. Set the switches to achieve the desired timeslot setting as shown in Table 8.**
13. On the DS-562I check the setting of DIP switch SW2-1 through SW2-6.  
**SW2-1 through SW2-6 controls the modules transmit address. Set the switches to achieve the desired transmit address setting as shown in Table 9.**
14. On the DS-562I check the setting of DIP switch SW3-1 through SW3-6.  
**SW2-1 through SW2-6 controls the modules receive address. Set the switches to achieve the desired receive address setting as shown in Table 9.**
15. On the DS-562I check the setting of DIP switch SW4-1.  
**SW4-1 turns the octet timing on or off. Right turns the service off, left turns the octet timing on. Set the switch to the desired position.**
16. On the DS-562I check the setting of DIP switch SW4-2.  
**SW4-2 selects normal or inverted receive clock Right sets normal polarity, left sets inverted. If the DS-562I does not reliably receive data from the 64/56 Kbps connector, the receive clock may have to be inverted. For the initial setup, set the switch to the right.**
17. On the DS-562I check the setting of DIP switch SW4-3.  
**SW4-3 selects normal or inverted transmit clock Right sets normal polarity, left sets inverted. If the user equipment does reliably receive data from the DS-562I's 64/56 Kbps connector, the transmit clock may have to be inverted. For the initial setup, set the switch to the right.**
18. On the DS-562I check the setting of DIP switch SW4-4.  
**SW4-4 turns the squelch on or off. Right turns the squelch off, left turns the squelch on (the DS-562I stops sending data out the 64/56 Kbps connector upon loss of valid receive address). Set the switch to the desired setting.**
19. On the DS-562I check the setting of DIP switch SW4-7.  
**SW4-7 sets the data rate. Right selects 64 Kbps, left selects 56 Kbps. Set the switch to the desired setting.**
20. On the DS-562I check the setting of DIP switch SW4-8.  
**SW4-8 selects the DS-562I transmit bus direction. Right selects transmit on B, receive on A (for drop and insert B), left selects transmit of A, receive on B (drop and insert A or terminal end). Set the switch to the desired setting.**
21. On the DS-562I check the setting of DIP switch SW5-1.  
**SW5-1 selects T1/E1. Right selects T1 carrier, left selects E1 carrier. Set the switch for the format being used.**

22. On the DS-562I check the setting of DIP switch SW5-2. SW5-2 turns the handshaking delay on or off. Right sets no delay, left sets an 8 microsecond delay.
23. Install the DS-562I into the IMUX 2000 chassis and allow a few seconds for the board to complete its power-up process.
24. Turn the DS-562I's service to ON (SW7-7). Allow a minimum of 16 seconds to ensure the common module has read all configuration data from the module.
25. Verify performance of the module using loopback testing.
26. When the configuration and performance of the DS-562I has been verified, set the module to remote mode (SW7-8).

**Table 16- 1. Connector J1 pin assignments for the MA-406IA Module Adapter**

Pin No.	Signal Name
4	SD(A) - Send Data
22	SD(B) - Send Data
5	ST(A) - Send Timing
23	ST(B) - Send Timing
6	RD(A) - Receive Data
24	RD(B) - Receive Data
7	RS(A) - Request To Send (RTS)
25	RS(B) - Request To Send (RTS)
8	RT(A) - Receive Timing
26	RT(B) - Receive Timing
9	CS(A) - Clear To Send
27	CS(B) - Clear To Send
10	Local Loopback
14	Remote Loopback
19	Signal Ground

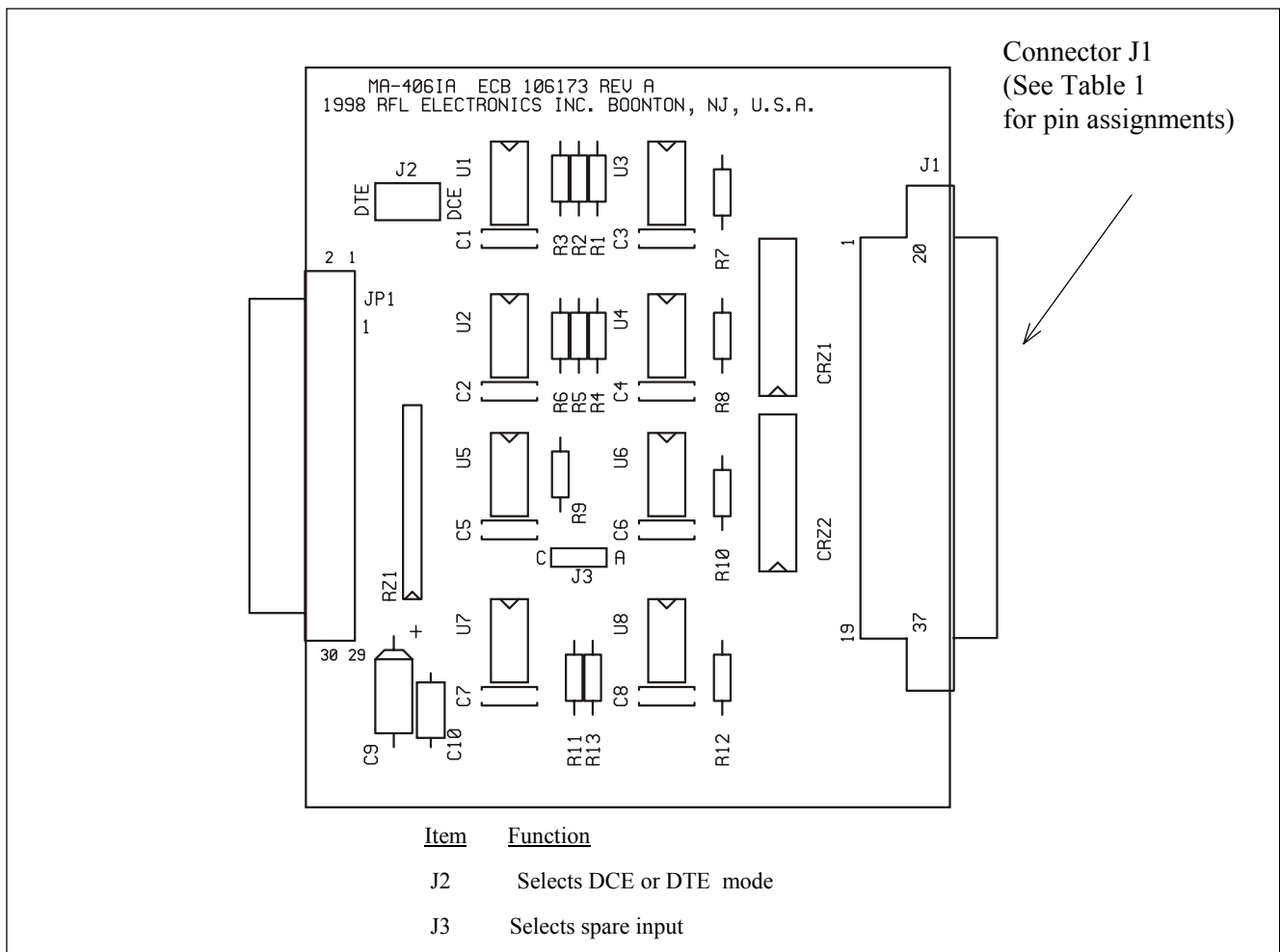

**Figure 16- 1. Controls and indicators, MA-406IA Module Adapter**

**Table 16- 2Connector J1 pin assignments for the MA-407I Module Adapter**

Pin No.	Signal Name
1	GND - Chassis
2	TD(A) - Transmit Data
9	TD(B) - Transmit Data
3	RD(A) - Receive Data
16	RD(B) - Receive Data
12	RT(A) - Receive Timing
13	RT(B) - Receive Timing
15	TT(A) - Transmit Timing
14	TT(B) - Transmit Timing

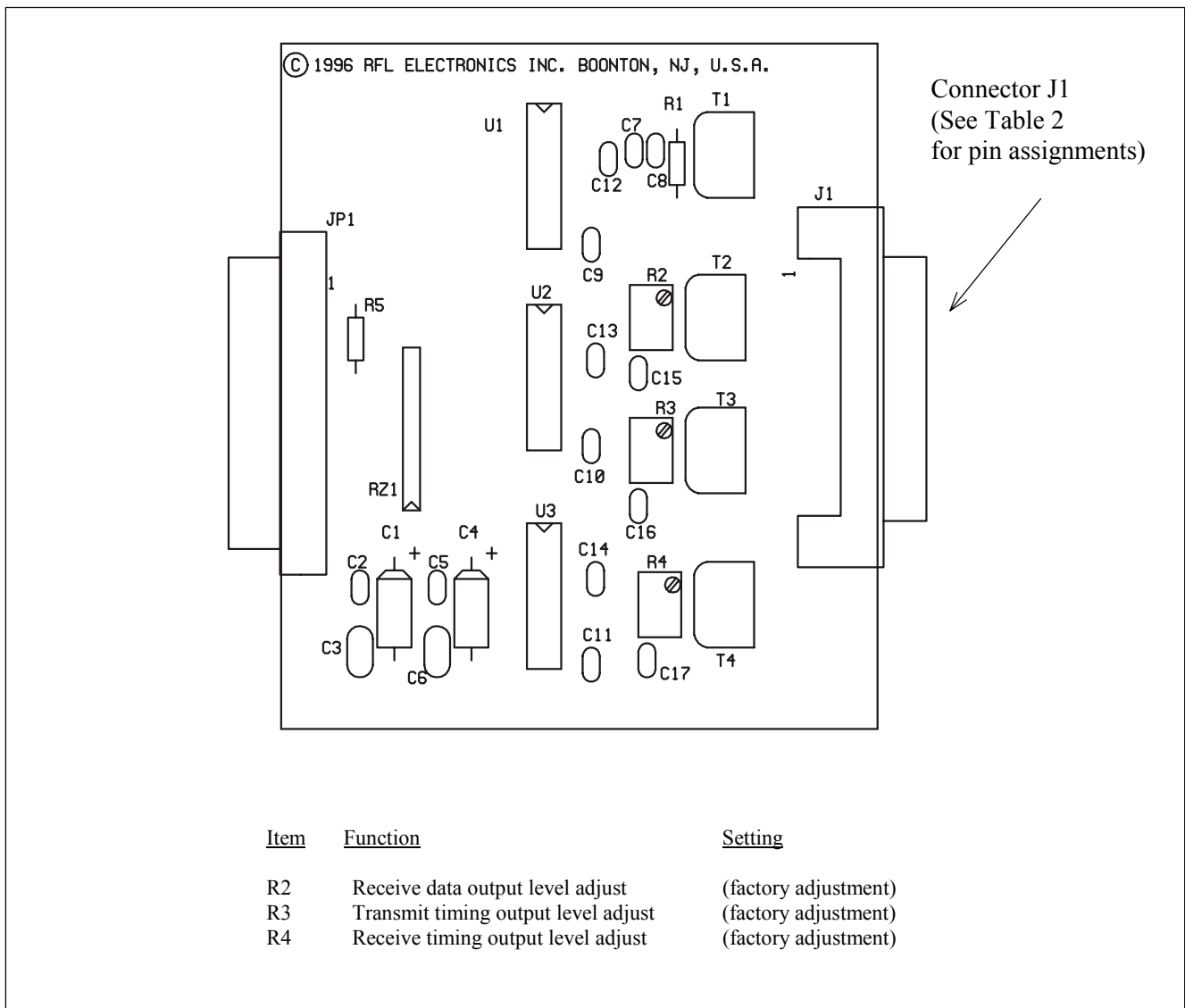
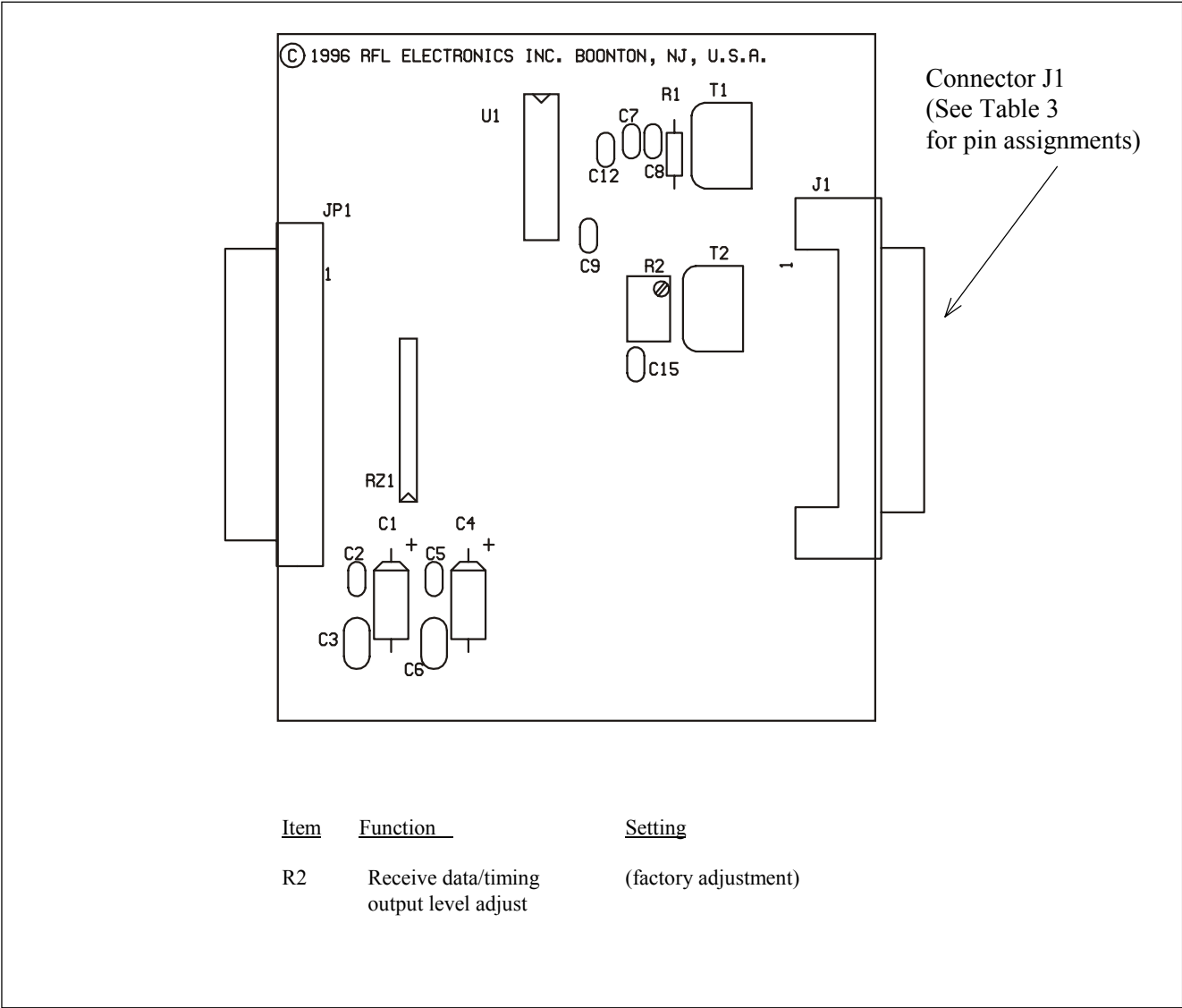

**Figure 16- 2. Controls and indicators, MA-407I Module Adapter**

**Table 16- 3. Connector J1 pin assignments for the MA-408I Module Adapter**

Pin No.	Signal Name
1	GND - Chassis
2	TD(A) - Transmit Data (input)
9	TD(B) - Transmit Data (input)
3	RD(A) - Receive Data (output)
16	RD(B) - Receive Data (output)

Note: The clock is embedded within the Transmit and Receive data signal.  
 The customer interface recovers the clock provided by the MA-408I



**Figure 16- 3 Controls and indicators, MA-408I Module Adapter**

**Table 16- 4 Connector J1 pin assignments for the MA-409IA Module Adapter**

V.35 Pin No.	Signal Name	DC-37S Pin No.
S	SD (B) - Send Data	22
P	SD (A) - Send Data	4
AA	SCT (B) - Serial Clock Transmit	23
Y	SCT (A) - Serial Clock Transmit	5
X	SCR (B) - Serial Clock Receive	26
V	SCR (A) - Serial Clock Receive	8
T	RD (B) - Receive Data	24
R	RD (A) - Receive Data	6
D	CB - Clear To Send (CTS)	9
C	CA - Request To Send (RTS)	7
B	AB - Signal Ground	19

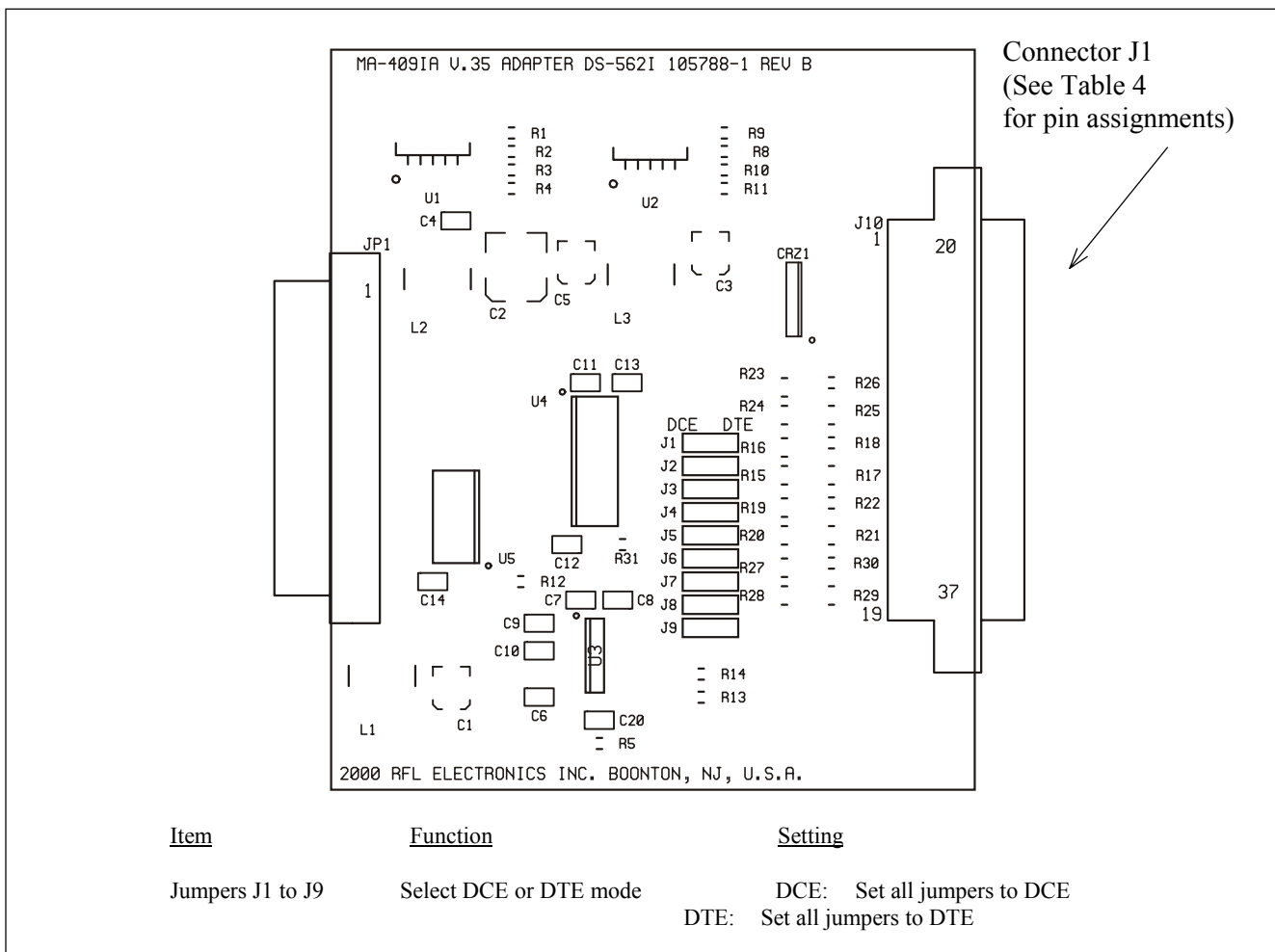

**Figure 16- 4. Controls and indicators, MA-409IA Module Adapter**

**Table 16- 5. Connector J1 pin assignments for the MA-410I Module adapter**

Pin No.	Signal Name
1	Chassis
2	TX Data A
3	Control A
4	Rx Data A
5	Indicate A
6	Signal Timing A
8	Signal Ground
9	Tx Data B
10	Control B
11	Rx Data B
12	Indicate B
13	Signal Timing B

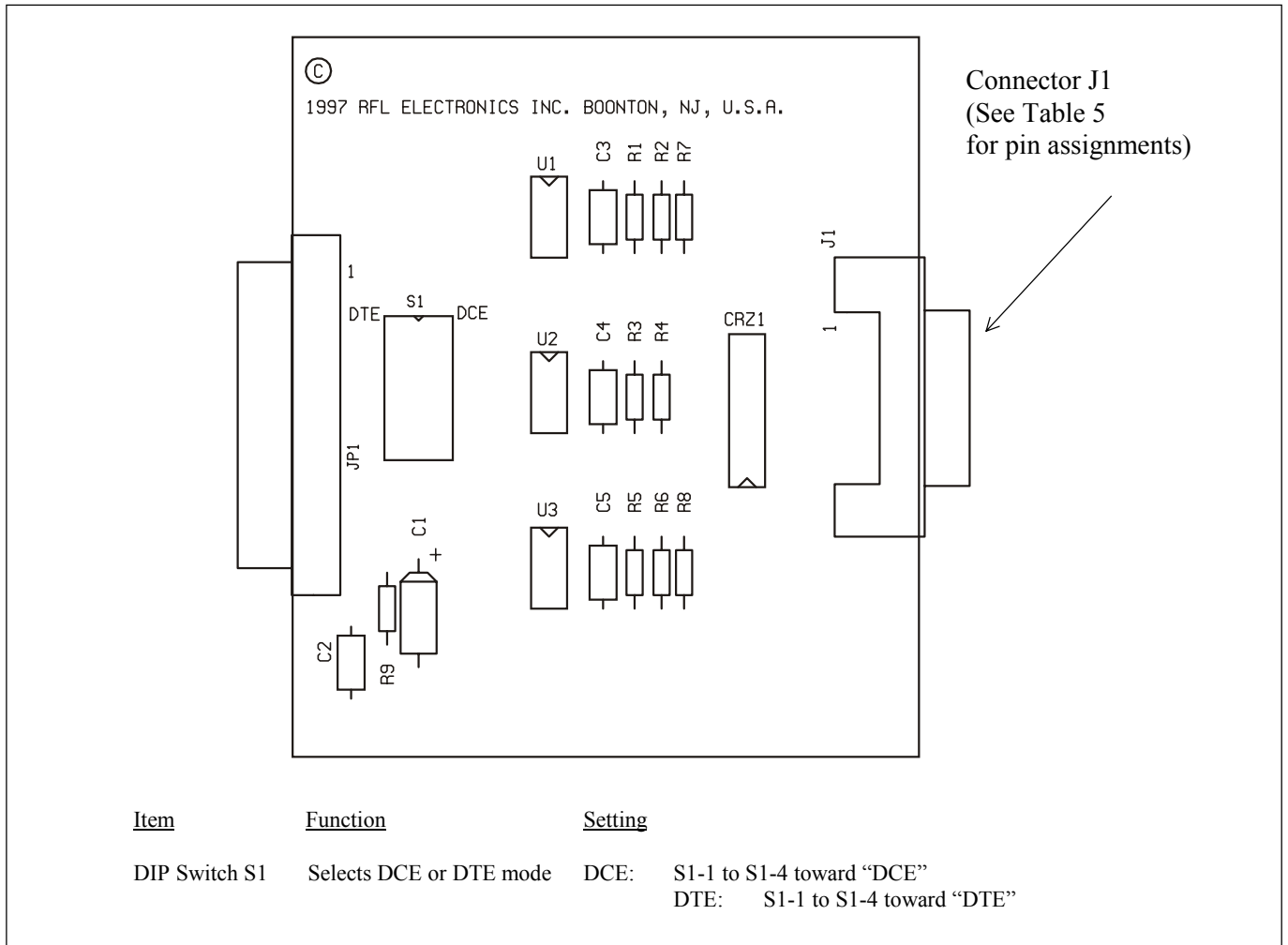

**Figure 16- 5 Controls and Indicators, MA-410I Module adapter**

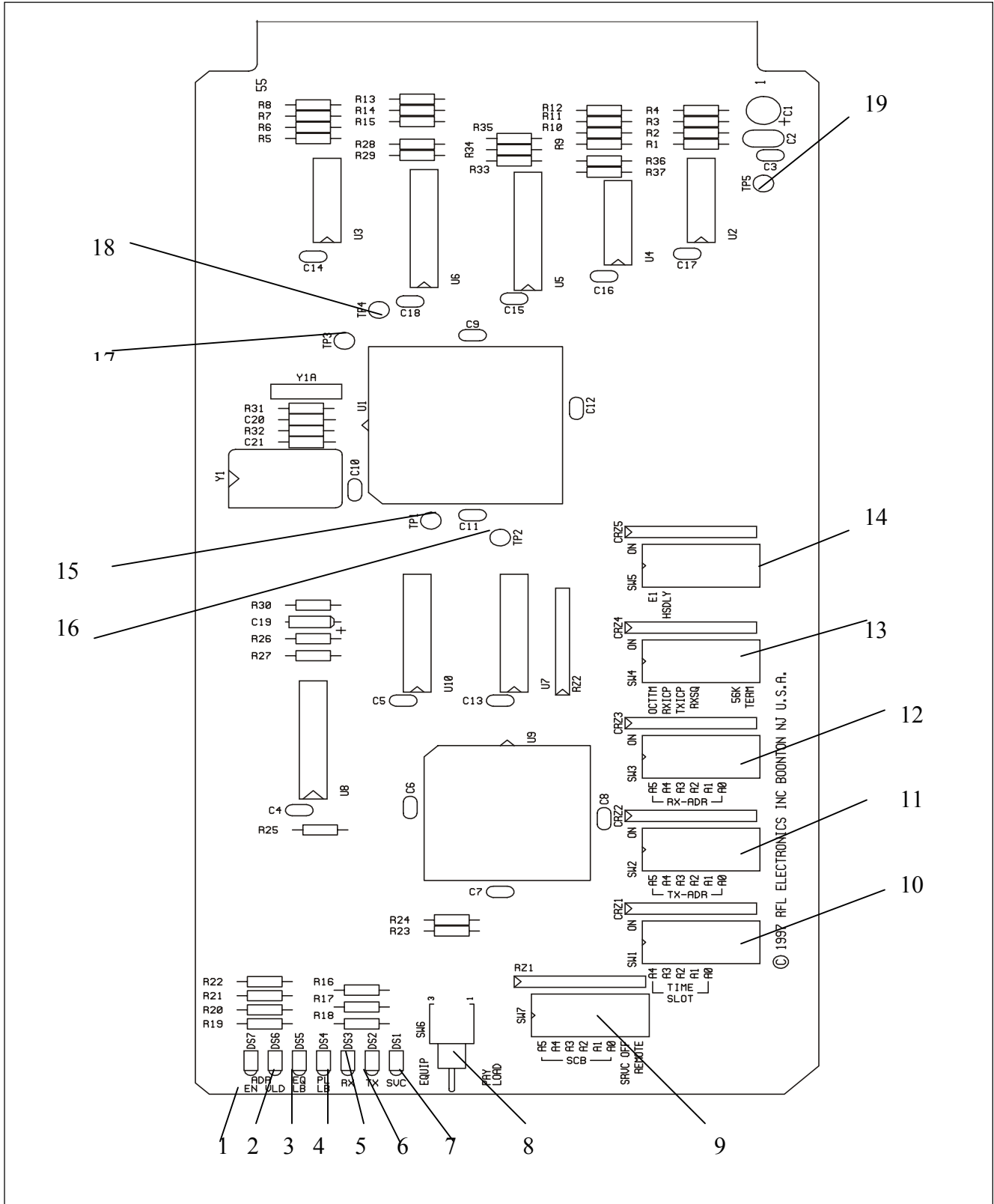

Figure 16- 6. Controls and indicators, RFL DS-5621 synchronous data module



Table 16- 6. Controls and indicators, DS-562I

Item	Name/Description	Function
1	LED indicator (green)	ADR EN: Lights when the transmit address is enabled (not set to 0). Used in 56K mode only.
2	LED indicator (green)	ADR VLD: Lights when the receive address is enabled (not set to 0) and matches the address embedded in the T1/E1 signal. Used in 56K mode only.
3	LED indicator (red)	EQ LB: Lights when the equipment loopback is enabled.
4	LED indicator (red)	PL LB: Lights when the payload loopback is enabled.
5	LED indicator (green)	RX: Lights when the DS-562I is receiving data from the remote equipment
6	LED indicator (green)	TX: Lights when the DS-562I is transmitting data to the remote equipment
7	LED indicator (green)	SVC: Lights when the DS-562I's service is enabled.
8	Switch SW6	This is a three position toggle switch: UP: Sets the board to equipment loopback. Center: Normal operation (no loopback, but can be overridden remotely). Down: Sets the board to payload loopback.  NOTE: If this unit is used for protective relaying applications, disable the protection equipment before using loopbacks.
9	DIP Switch SW7	SW7-1 to SW7-6 Sets the SCB address, see Table 7.
		SW7-7 Sets the DS-562I service ON or OFF: ON(up): Service ON (board enabled). OFF(down): Service OFF (board disabled).
		SW7-8 Sets the DS-562I for local or remote mode: ON(up): Local (settings obtained from DIP switches). OFF(down): Remote (settings obtained from SCB).
10	DIP Switch SW1	SW1-1 to SW1-5 Sets the T1/E1 timeslot, see Table 8.
11	DIP Switch SW2	SW2-1 to SW2-6 In 56 Kbps mode, sets the transmit address, see Table 9.
12	DIP Switch SW3	SW3-1 to SW3-6 In 56 Kbps mode, sets the receive address, see Table 9.
13	DIP Switch SW4	SW4-1 Enables/disables octet timing: ON(right): Octet timing OFF. OFF(left): Octet timing ON.
		SW4-2 Sets the receive clock polarity: ON(right): Normal polarity. OFF(left): Inverted polarity.
		SW4-3 Sets the transmit clock polarity: ON(right): Normal polarity. OFF(left): Inverted polarity.
		SW4-4 Sets receiver squelch: ON(right): Squelch OFF. OFF(left): Squelch ON (DS-562I stops output to user equipment upon loss of valid address).
		SW4-7 Sets the data rate: ON(right): 64 Kbps. OFF(left): 56 Kbps.
		SW4-8 Sets the T1/E1 transmit bus direction: ON(right): Transmit on "B" (receive on "A"). OFF(left): Transmit on "A" (receive on "B").
		SW4-5 Sets the carrier type: ON(right): T1 carrier. OFF(left): E1 carrier.
14	DIP Switch SW5	SW5-2 Controls the handshaking delay: ON(right): No delay. OFF(left): 8 microseconds delay (approx.)
		SW5-1
15	Test point TP1	Transmit data
16	Test point TP2	Receive data
17	Test point TP3	Transmit clock
18	Test point TP4	Receive clock
19	Test point TP5	Ground

**Table 16- 7. SCB Address Settings, RFL DS-562I**

<b>Module Address</b>	<b>SW7-1 (A5)</b>	<b>SW7-2 (A4)</b>	<b>SW7-3 (A3)</b>	<b>SW7-4 (A2)</b>	<b>SW7-5 (A1)</b>	<b>SW7-6 (A0)</b>
1	DOWN	DOWN	DOWN	DOWN	DOWN	UP
2	DOWN	DOWN	DOWN	DOWN	UP	DOWN
3	DOWN	DOWN	DOWN	DOWN	UP	UP
4	DOWN	DOWN	DOWN	UP	DOWN	DOWN
5	DOWN	DOWN	DOWN	UP	DOWN	UP
6	DOWN	DOWN	DOWN	UP	UP	DOWN
7	DOWN	DOWN	DOWN	UP	UP	UP
8	DOWN	DOWN	UP	DOWN	DOWN	DOWN
9	DOWN	DOWN	UP	DOWN	DOWN	UP
10	DOWN	DOWN	UP	DOWN	UP	DOWN
11	DOWN	DOWN	UP	DOWN	UP	UP
12	DOWN	DOWN	UP	UP	DOWN	DOWN
13	DOWN	DOWN	UP	UP	DOWN	UP
14	DOWN	DOWN	UP	UP	UP	DOWN
15	DOWN	DOWN	UP	UP	UP	UP
16	DOWN	UP	DOWN	DOWN	DOWN	DOWN
17	DOWN	UP	DOWN	DOWN	DOWN	UP
18	DOWN	UP	DOWN	DOWN	UP	DOWN
19	DOWN	UP	DOWN	DOWN	UP	UP
20	DOWN	UP	DOWN	UP	DOWN	DOWN
21	DOWN	UP	DOWN	UP	DOWN	UP
22	DOWN	UP	DOWN	UP	UP	DOWN
23	DOWN	UP	DOWN	UP	UP	UP
24	DOWN	UP	UP	DOWN	DOWN	DOWN
25	DOWN	UP	UP	DOWN	DOWN	UP
26	DOWN	UP	UP	DOWN	UP	DOWN
27	DOWN	UP	UP	DOWN	UP	UP
28	DOWN	UP	UP	UP	DOWN	DOWN
29	DOWN	UP	UP	UP	DOWN	UP
30	DOWN	UP	UP	UP	UP	DOWN
31	DOWN	UP	UP	UP	UP	UP
32	UP	DOWN	DOWN	DOWN	DOWN	DOWN
33	UP	DOWN	DOWN	DOWN	DOWN	UP
34	UP	DOWN	DOWN	DOWN	UP	DOWN
35	UP	DOWN	DOWN	DOWN	UP	UP
36	UP	DOWN	DOWN	UP	DOWN	DOWN

**Table 16- 8. Timeslot settings, RFL DS-562I**

<b>T1 Timeslot</b>	<b>SW1-1 (A4)</b>	<b>SW1-2 (A3)</b>	<b>SW1-3 (A2)</b>	<b>SW1-4 (A1)</b>	<b>SW1-5 (A0)</b>	<b>E1 Timeslot</b>
1	RIGHT	RIGHT	RIGHT	RIGHT	RIGHT	N/A
2	RIGHT	RIGHT	RIGHT	RIGHT	LEFT	1
3	RIGHT	RIGHT	RIGHT	LEFT	RIGHT	2
4	RIGHT	RIGHT	RIGHT	LEFT	LEFT	3
5	RIGHT	RIGHT	LEFT	RIGHT	RIGHT	4
6	RIGHT	RIGHT	LEFT	RIGHT	LEFT	5
7	RIGHT	RIGHT	LEFT	LEFT	RIGHT	6
8	RIGHT	RIGHT	LEFT	LEFT	LEFT	7
9	RIGHT	LEFT	RIGHT	RIGHT	RIGHT	8
10	RIGHT	LEFT	RIGHT	RIGHT	LEFT	9
11	RIGHT	LEFT	RIGHT	LEFT	RIGHT	10
12	RIGHT	LEFT	RIGHT	LEFT	LEFT	11
13	RIGHT	LEFT	LEFT	RIGHT	RIGHT	12
14	RIGHT	LEFT	LEFT	RIGHT	LEFT	13
15	RIGHT	LEFT	LEFT	LEFT	RIGHT	14
16	RIGHT	LEFT	LEFT	LEFT	LEFT	15
17	LEFT	RIGHT	RIGHT	RIGHT	RIGHT	16 *
18	LEFT	RIGHT	RIGHT	RIGHT	LEFT	17
19	LEFT	RIGHT	RIGHT	LEFT	RIGHT	18
20	LEFT	RIGHT	RIGHT	LEFT	LEFT	19
21	LEFT	RIGHT	LEFT	RIGHT	RIGHT	20
22	LEFT	RIGHT	LEFT	RIGHT	LEFT	21
23	LEFT	RIGHT	LEFT	LEFT	RIGHT	22
24	LEFT	RIGHT	LEFT	LEFT	LEFT	23
N/A	LEFT	LEFT	RIGHT	RIGHT	RIGHT	24
N/A	LEFT	LEFT	RIGHT	RIGHT	LEFT	25
N/A	LEFT	LEFT	RIGHT	LEFT	RIGHT	26
N/A	LEFT	LEFT	RIGHT	LEFT	LEFT	27
N/A	LEFT	LEFT	LEFT	RIGHT	RIGHT	28
N/A	LEFT	LEFT	LEFT	RIGHT	LEFT	29
N/A	LEFT	LEFT	LEFT	LEFT	RIGHT	30
N/A	LEFT	LEFT	LEFT	LEFT	LEFT	31

\* Do not use timeslot 16 in an E1 system which uses CAS (channel associated signalling).

**Table 16- 9. Transmit & Receive Address Settings, RFL DS-562I(Used only in 56 Kbps mode)**

<b>Trans/Rcv Address</b>	<b>SW2/3-1 (A5)</b>	<b>SW2/3-2 (A4)</b>	<b>SW2/3-3 (A3)</b>	<b>SW2/3-4 (A2)</b>	<b>SW2/3-5 (A1)</b>	<b>SW2/3-6 (A0)</b>
0 (disabled)	RIGHT	RIGHT	RIGHT	RIGHT	RIGHT	RIGHT
1	RIGHT	RIGHT	RIGHT	RIGHT	RIGHT	LEFT
2	RIGHT	RIGHT	RIGHT	RIGHT	LEFT	LEFT
3	RIGHT	RIGHT	RIGHT	RIGHT	LEFT	LEFT
4	RIGHT	RIGHT	RIGHT	LEFT	RIGHT	RIGHT
5	RIGHT	RIGHT	RIGHT	LEFT	RIGHT	LEFT
6	RIGHT	RIGHT	RIGHT	LEFT	LEFT	RIGHT
7	RIGHT	RIGHT	RIGHT	LEFT	LEFT	LEFT
8	RIGHT	RIGHT	LEFT	RIGHT	RIGHT	RIGHT
9	RIGHT	RIGHT	LEFT	RIGHT	RIGHT	LEFT
10	RIGHT	RIGHT	LEFT	RIGHT	LEFT	RIGHT
11	RIGHT	RIGHT	LEFT	RIGHT	LEFT	LEFT
12	RIGHT	RIGHT	LEFT	LEFT	RIGHT	RIGHT
13	RIGHT	RIGHT	LEFT	LEFT	RIGHT	LEFT
14	RIGHT	RIGHT	LEFT	LEFT	LEFT	RIGHT
15	RIGHT	RIGHT	LEFT	LEFT	LEFT	LEFT
16	RIGHT	LEFT	RIGHT	RIGHT	RIGHT	RIGHT
17	RIGHT	LEFT	RIGHT	RIGHT	RIGHT	LEFT
18	RIGHT	LEFT	RIGHT	RIGHT	LEFT	RIGHT
19	RIGHT	LEFT	RIGHT	RIGHT	LEFT	LEFT
20	RIGHT	LEFT	RIGHT	LEFT	RIGHT	RIGHT
21	RIGHT	LEFT	RIGHT	LEFT	RIGHT	LEFT
22	RIGHT	LEFT	RIGHT	LEFT	LEFT	RIGHT
23	RIGHT	LEFT	RIGHT	LEFT	LEFT	LEFT
24	RIGHT	LEFT	LEFT	RIGHT	RIGHT	RIGHT
25	RIGHT	LEFT	LEFT	RIGHT	RIGHT	LEFT
26	RIGHT	LEFT	LEFT	RIGHT	LEFT	RIGHT
27	RIGHT	LEFT	LEFT	RIGHT	LEFT	LEFT
28	RIGHT	LEFT	LEFT	LEFT	RIGHT	RIGHT
29	RIGHT	LEFT	LEFT	LEFT	RIGHT	LEFT
30	RIGHT	LEFT	LEFT	LEFT	LEFT	RIGHT
31	RIGHT	LEFT	LEFT	LEFT	LEFT	LEFT
32	LEFT	RIGHT	RIGHT	RIGHT	RIGHT	RIGHT
33	LEFT	RIGHT	RIGHT	RIGHT	RIGHT	LEFT
34	LEFT	RIGHT	RIGHT	RIGHT	LEFT	LEFT
35	LEFT	RIGHT	RIGHT	RIGHT	LEFT	LEFT
36	LEFT	RIGHT	RIGHT	LEFT	RIGHT	RIGHT
37	LEFT	RIGHT	RIGHT	LEFT	RIGHT	LEFT
38	LEFT	RIGHT	RIGHT	LEFT	LEFT	RIGHT
39	LEFT	RIGHT	RIGHT	LEFT	LEFT	LEFT
40	LEFT	RIGHT	LEFT	RIGHT	RIGHT	RIGHT
41	LEFT	RIGHT	LEFT	RIGHT	RIGHT	LEFT
42	LEFT	RIGHT	LEFT	RIGHT	LEFT	RIGHT
43	LEFT	RIGHT	LEFT	RIGHT	LEFT	LEFT
44	LEFT	RIGHT	LEFT	LEFT	RIGHT	RIGHT
45	LEFT	RIGHT	LEFT	LEFT	RIGHT	LEFT

**Table 16- 9. (continued) Transmit & Receive Address Settings, RFL DS-562I  
(Used only in 56 Kbps mode)**

<b>Trans/Rcv Address</b>	<b>SW2/3-1 (A5)</b>	<b>SW2/3-2 (A4)</b>	<b>SW2/3-3 (A3)</b>	<b>SW2/3-4 (A2)</b>	<b>SW2/3-5 (A1)</b>	<b>SW2/3-6 (A0)</b>
46	LEFT	RIGHT	LEFT	LEFT	LEFT	RIGHT
47	LEFT	RIGHT	LEFT	LEFT	LEFT	LEFT
48	LEFT	LEFT	RIGHT	RIGHT	RIGHT	RIGHT
49	LEFT	LEFT	RIGHT	RIGHT	RIGHT	LEFT
50	LEFT	LEFT	RIGHT	RIGHT	LEFT	RIGHT
51	LEFT	LEFT	RIGHT	RIGHT	LEFT	LEFT
52	LEFT	LEFT	RIGHT	LEFT	RIGHT	RIGHT
53	LEFT	LEFT	RIGHT	LEFT	RIGHT	LEFT
54	LEFT	LEFT	RIGHT	LEFT	LEFT	RIGHT
55	LEFT	LEFT	RIGHT	LEFT	LEFT	LEFT
56	LEFT	LEFT	LEFT	RIGHT	RIGHT	RIGHT
57	LEFT	LEFT	LEFT	RIGHT	RIGHT	LEFT
58	LEFT	LEFT	LEFT	RIGHT	LEFT	RIGHT
59	LEFT	LEFT	LEFT	RIGHT	LEFT	LEFT
60	LEFT	LEFT	LEFT	LEFT	RIGHT	RIGHT
61	LEFT	LEFT	LEFT	LEFT	RIGHT	LEFT
62	LEFT	LEFT	LEFT	LEFT	LEFT	RIGHT
63	LEFT	LEFT	LEFT	LEFT	LEFT	LEFT

## SHORT HAUL FIBER INTERFACE

The MA-600 is a Short Haul Fiber Interface Module that can be used with the RFL DS562I Synchronous Data Module. The Short Haul Fiber Interface Module is a single width module, and consists of an input section (detector) and an output section (emitter). The module is mounted at the rear of an RFL IMUX 2000 chassis, directly opposite the DS562I module. The input power requirement is +5 Volts at 175 mA maximum from the chassis supply. The input drive signals are TTL logic-level, generated by the DS562I.

**Table 16- 10 Short Haul Fiber Interface Module, Characteristics**

Assembly Number	Type	Wavelength/ Mode	Fiber Optic Connector Type	Receiver Sensitivity	System Gain	Typical Distance
9547-600	LED Emitter/Detector	850nm/ multimode	ST	-27dBm	8dB	Up to 1km (0.6mi.)

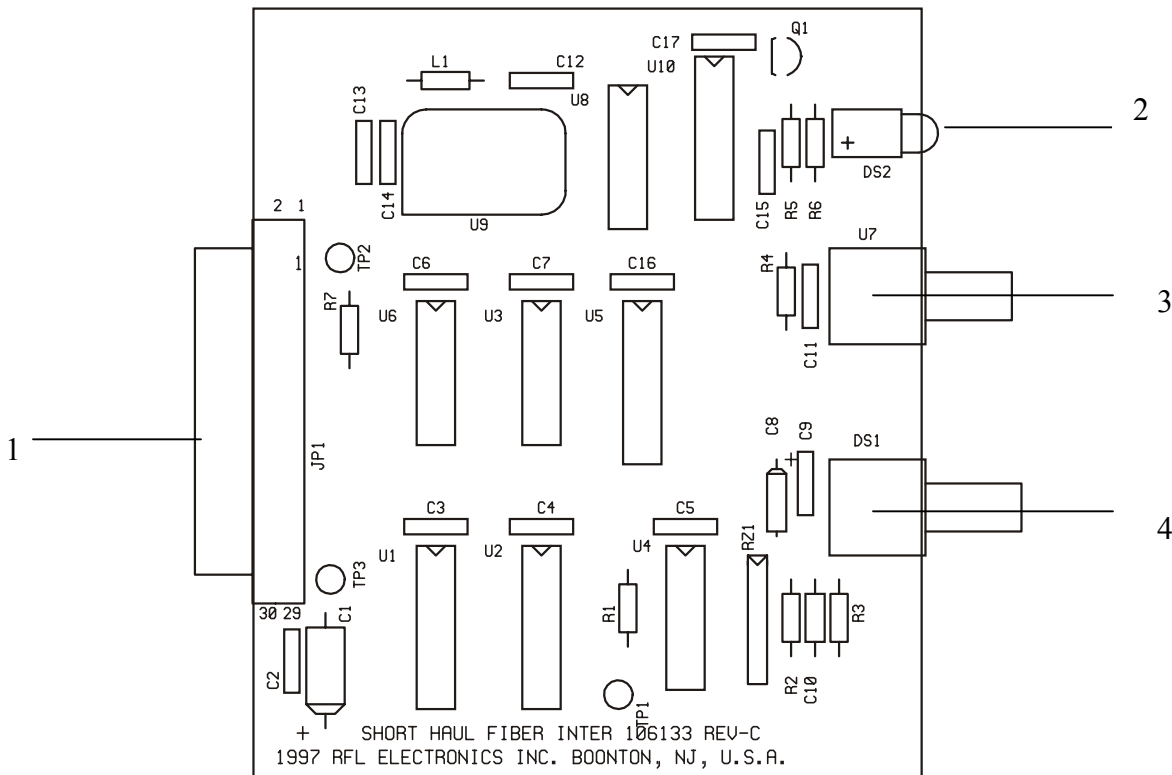

**Figure 16- 7 Controls and indicators, MA-600 Module Adapter**

**Table 16- 11. Short Haul Fiber Interface Module, Controls and indicators**

Item	Name/Description	Function
1	JP1 Connector	Motherboard connector (connects to the IMUX 2000 motherboard directly behind the DS562I module)
2	DS2 Fiber Data LED	Lights green when data (transitions) is present at the fiber optic receiver
3	U7 Fiber Optic Detector	Connects to fiber optic cable from remote end
4	DS1 Fiber Optic Emitter	Connects to fiber optic cable to remote end

The IMUX Short Haul Fiber module takes three signals from the DS562I and multiplexes them over a single fiber. The signals include transmit and receive timing and transmit data. The receive data coming from the other fiber is converted to TTL levels for use by the DS562I. An activity LED indicates that data is present on the incoming fiber. There are no jumpers or settings to be made on the unit.

The outgoing clocks and transmit data are asynchronously sampled at a 2.5 MHz rate generated by an oscillator. The three resulting bits are put into a serial 8-bit word by a multiplexer. The remaining 5 bits create a fixed pattern which is used by the receiving interface to determine frame alignment. This pattern is shown below. The serial signal is clocked out at 2.5 MHz and drives the fiber transmitter DS1.

The receive signal is clocked by the receive timing signal. This data is not modulated and therefore is passed to the DS562I in TTL format exactly as received. The receive data is also used to retrigger a multivibrator. If no transitions occur within a specified time, the rear panel LED DS2 is extinguished.

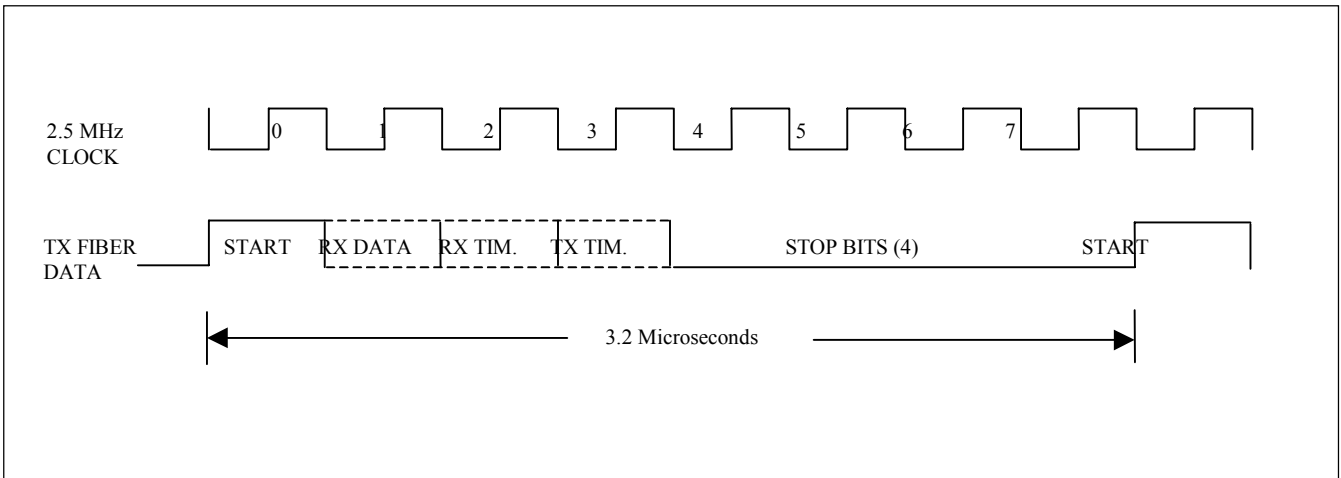

**Figure 16- 8. Short Haul Fiber Timing Diagram**

## IMUX 2000 MULTIPLEXER INTERFACING

This section describes timing configuration settings when interfacing the IMUX 2000 Multiplexer with other RFL products using RS-449 communications. The IMUX 2000 can be interfaced with the RFL 9300, RFL 9700, RFL 9700A, RFL 9720 and RFL 9745. It is highly recommended that clock and data transitions are confirmed with a scope to insure proper system operation.

### IMUX 2000 MULTIPLEXER AND RFL 9300 (RS-449)

Interfacing an IMUX 2000 with an RFL 9300 can be accomplished as follows:

A. The programmable jumpers on the 9300 Direct Digital I/O module shall be positioned as follows:

J2 (Send Timing): "A" Position

J3 (Receive Timing): "A" Position

B. The configuration of the IMUX 2000 RS-449 Channel Card shall be as follows:

1. DS-562I with MA-406IA I/O

MA-406IA I/O: J2 jumpers in DCE mode

J3 in any position

DS-562I, Switch SW4-2 (Receive Clock Polarity): Normal - ON (Right)

DS-562I, Switch SW4-3 (Transmit Clock Polarity): Normal - ON (Right)

2. DS-562I with MA-600 short haul fiber I/O

MA-600 I/O: No jumpers to set

DS-562I, Switch SW4-2 (Receive Clock Polarity): Normal - ON (Right)

DS-562I, Switch SW4-3 (Transmit Clock Polarity): Normal - ON (Right)

3. DS-562B with MA-406 I/O

MA-406 I/O: No jumpers to set

DS-562B, J1 (Send Timing Clock): Normal - Left (Middle and Front Posts)

DS-562B, J5 (Timing Mode): Internal - UP (Upper and Middle Posts)

C. Confirm Clock and Data Transitions to Insure Proper System Operation as follows:

1. RFL 9300 CCM: The positive edge of the RxClock (TP5) must be in the center of the RxData bit (TP4).

2. IMUX 2000: DS-562I - The positive edge of the TxClock (TP3) must be in the center of the TxData bit (TP1).

DS-562B - The positive edge of the TxClock (U30-Pin 3) must be in the center of the TxData bit (U30-Pin 2).



## **IMUX 2000 MULTIPLEXER AND RFL 9700 “ORIGINAL” (RS-449)**

Interfacing an IMUX 2000 with an RFL 9700 can be accomplished as follows:

A. Configuration of RFL 9700:

97 DIG RX: ECB# 101563: No Clock Polarity Jumper

ECB# 101563-1: J2 - “B” Position

97 DIG TX: No Clock Polarity Jumper

B. The configuration of the IMUX 2000 RS-449 Channel Card shall be as follows:

1. DS-562I with MA-406IA I/O

MA-406IA I/O: J2 jumpers in DCE mode

J3 in any position

DS-562I, Switch SW4-2 (Receive Clock Polarity): ECB #101563: Inverted - OFF (Left)

ECB #101563-1: Normal - ON (Right)

DS-562I, Switch SW4-3 (Transmit Clock Polarity): Normal - ON (Right)

2. DS-562B with MA-406 I/O

MA-406 I/O: No jumpers to set

DS-562B, J1 (Send Timing Clock): Normal - Left (Middle and Front Posts)

DS-562B, J5 (Timing Mode): Internal - UP (Upper and Middle Posts)

NOTE: If the RFL 9700 uses 97 DIG RX having ECB# 101563 (No J2), the signal lines at Tx Timing “Plus” (Pin 8 of DB-37 Connector) and Rx Timing “Minus” (Pin 26 of DB-37 Connector) must be switched by modifying cable in order to obtain proper RxClock Polarity. Confirm clock and data transitions before modifying the cable.

C. Confirm Clock and Data Transitions to Insure Proper System Operation as follows:

1. RFL 97 DIG RX: The positive edge of the RxClock (TP2) must be in the center of the RxData bit (TP1).

2. IMUX 2000: DS-562I - The positive edge of the TxClock (TP3) must be in the center of the TxData bit (TP1).  
DS-562B - The positive edge of the TxClock (U30-Pin 3) must be in the center of the TxData bit (U30-Pin 2).

## **IMUX 2000 MULTIPLEXER AND RFL 9700A (RS-449)**

Interfacing an IMUX 2000 with an RFL 9700A can be accomplished as follows:

A. Configuration of RFL 9700A:

97A DIG RX: J2: "B" Position

97A DIG TX: J2: "B" Position

B. The configuration of the IMUX 2000 RS-449 Channel Card shall be as follows:

1. DS-562I with MA-406IA I/O

MA-406IA I/O: J2 jumpers in DCE mode

J3 in any position

DS-562I, Switch SW4-2 (Receive Clock Polarity): Normal - ON (Right)

DS-562I, Switch SW4-3 (Transmit Clock Polarity): Normal - ON (Right)

2. DS-562B with MA-406 I/O

MA-406 I/O: No jumpers to set

DS-562B, J1 (Send Timing Clock): Normal - Left (Middle and Front Posts)

DS-562B, J5 (Timing Mode): Internal - UP (Upper and Middle Posts)

C. Confirm Clock and Data Transitions to Insure Proper System Operation as follows:

1. RFL 97A DIG RX: The positive edge of the RxClock (TP2) must be in the center of the RxData bit (TP1).

2. IMUX 2000: DS-562I - The positive edge of the TxClock (TP3) must be in the center of the TxData bit (TP1).

DS-562B - The positive edge of the TxClock (U30-Pin 3) must be in the center of the TxData bit (U30-Pin 2).

## **IMUX 2000 MULTIPLEXER AND RFL 9720 (RS-449)**

Interfacing an IMUX 2000 with an RFL 9720 can be accomplished as follows:

- A. The programmable jumpers on the piggyback board of the RFL 9720 module shall be positioned as follows:

J6 (Send Timing): "B" Position

J7 (Receive Timing): "B" Position

- B. The configuration of the IMUX 2000 RS-449 Channel Card shall be as follows:

1. DS-562I with MA-406IA I/O

MA-406IA I/O: J2 jumpers in DCE mode

J3 in any position

DS-562I, Switch SW4-2 (Receive Clock Polarity): Normal - ON (Right)

DS-562I, Switch SW4-3 (Transmit Clock Polarity): Normal - ON (Right)

2. DS-562B with MA-406 I/O

MA-406 I/O: No jumpers to set

DS-562B, J1 (Send Timing Clock): Normal - Left (Middle and Front Posts)

DS-562B, J5 (Timing Mode): Internal - UP (Upper and Middle Posts)

- C. Confirm Clock and Data Transitions to Insure Proper System Operation as follows:

1. RFL 9720 CCM: The positive edge of the RxClock (TP17) must be in the center of the RxData bit (TP16).

2. IMUX 2000: DS-562I - The positive edge of the TxClock (TP3) must be in the center of the TxData bit (TP1).

DS-562B - The positive edge of the TxClock (U30-Pin 3) must be in the center of the TxData bit (U30-Pin 2).

## IMUX 2000 MULTIPLEXER AND RFL 9745 (RS-449)

Interfacing an IMUX 2000 with an RFL 9745 can be accomplished as follows:

A. The programmable jumpers on the 9745 RS-449 I/O shall be positioned as follows:

J1 (Send Timing): "Invert" Position

J2 (Receive Timing): "Invert" Position

B. The configuration of the IMUX 2000 RS-449 Channel Card shall be as follows:

1. DS-562I with MA-406IA I/O

MA-406IA I/O: J2 jumpers in DCE mode

J3 in any position

DS-562I, Switch SW4-2 (Receive Clock Polarity): Normal - ON (Right)

DS-562I, Switch SW4-3 (Transmit Clock Polarity): Normal - ON (Right)

2. DS-562I with MA-600 short haul fiber I/O

MA-600 I/O: No jumpers to set

DS-562I, Switch SW4-2 (Receive Clock Polarity): Normal - ON (Right)

DS-562I, Switch SW4-3 (Transmit Clock Polarity): Normal - ON (Right)

3. DS-562B with MA-406 I/O

MA-406 I/O: No jumpers to set

DS-562B, J1 (Send Timing Clock): Normal - Left (Middle and Front Posts)

DS-562B, J5 (Timing Mode): Internal - UP (Upper and Middle Posts)

C. Confirm Clock and Data Transitions to Insure Proper System Operation as follows:

**1. RFL 9745 RS-449 I/O: The positive edge of the RxClock (TP4 or RT) must be in the center of the RxData bit (TP2 or RD).**

**2. IMUX 2000: DS-562I - The positive edge of the TxClock (TP3) must be in the center of the TxData bit (TP1).**

**DS-562B - The positive edge of the TxClock (U30-Pin 3) must be in the center of the TxData bit (U30-Pin 2).**

## **USING THE DS-562I AND DS-562B END-TO-END**

The DS-562B must be setup for Mode 2 operation. This is accomplished by setting SW3-8 in the ON (UP) position.

### **RS-449 LOOPBACK “PLUGS”**

ONLY the data lines are “looped”. The Timing lines must not be looped back because the DS-562I (or DS-562B) provide both transmit and receive clocks.

“Looped Signals”:     Send Data + (Pin 4) > Receive Data + (Pin 6)

                              Send Data - (Pin 22) > Receive Data - (Pin 24)

In addition, there is no guarantee that the TxData will be valid on the positive edge of the TxClock. Data errors may occur if data is sampled near the edge instead of the center of the data bit. It is therefore recommended that a “split” cable be used for testing purposes such that one end “sends data” and the other end “receives data”. Confirm both directions by switching the cable ends.

## **FUNCTIONAL DESCRIPTION**

The following is a basic description of how the RFL DS-562I module operates. A simplified block diagram of the module is shown in Figure 9.

### **MODULE OVERVIEW**

The DS-562I synchronous data module is a channel card for use in the IMUX 2000 system. It transmits and receives data from/to the T1/E1 bus and generates and receives data via an I/O adapter module. The module can be set up and interrogated remotely via the SCB of the IMUX 2000. DIP switches enable the user to set up the module locally. Seven front panel LEDs indicate to the user the status of the module.

The module provides the following five major functions: T1/E1 transmit interface, T1/E1 receive interface, loopback, SCB interfacing, and control logic. The Actel 1280XL and its associated circuitry handles all T1/E1 communication and I/O. The Actel 1020B connects the Actel 1280XL with the SCB of the IMUX 2000. Miscellaneous other circuits are present to handle the remaining functions. A bank of dip switches is provided to select the module parameters, a toggle switch is provided to select the loopback function, and LEDs provide the user with module status.

### **COMMS FPGA CIRCUIT**

The Comms FPGA circuit consists of an Actel 1280XL which is the heart of the DS-562I module. It has several main functions which include T1/E1 receive and transmit control, SCB interfacing, LED control, reading switch settings, equipment and payload loopback, addressing and CRC, and I/O decoding for G.703. The Actel contains two phase locked loops for generating the 56 or 64 Kbps clocks synchronous to the T1/E1 input signals.

### **SCB FPGA CIRCUIT**

The SCB FPGA circuit consists of an Actel 1020B which is used to communicate with the CM3B/C module via the SCB. A DIP switch is provided to allow the user to set the SCB address of the module which is read by the SCB FPGA. The DS-562I module has a type ID of 119 encoded into the SCB FPGA device.

### **I/O ADAPTER MODULES**

The signals to and from the user equipment pass through the I/O module. The I/O module performs the required level shifting between the DS-562I and the user equipment, thus allowing the same channel card to be used with any one of four different types of communication interface I/O adapter modules.

### **T1/E1 TRANSMIT CIRCUIT**

The 56 or 64 Kbps serial data from the user equipment is routed to the the transmit circuit which synchronizes the signals and then feeds them to the T1/E1 data bus. If addressing is being used in the 56 Kbps mode, the transmit address is inserted into the data stream along with security coding information.

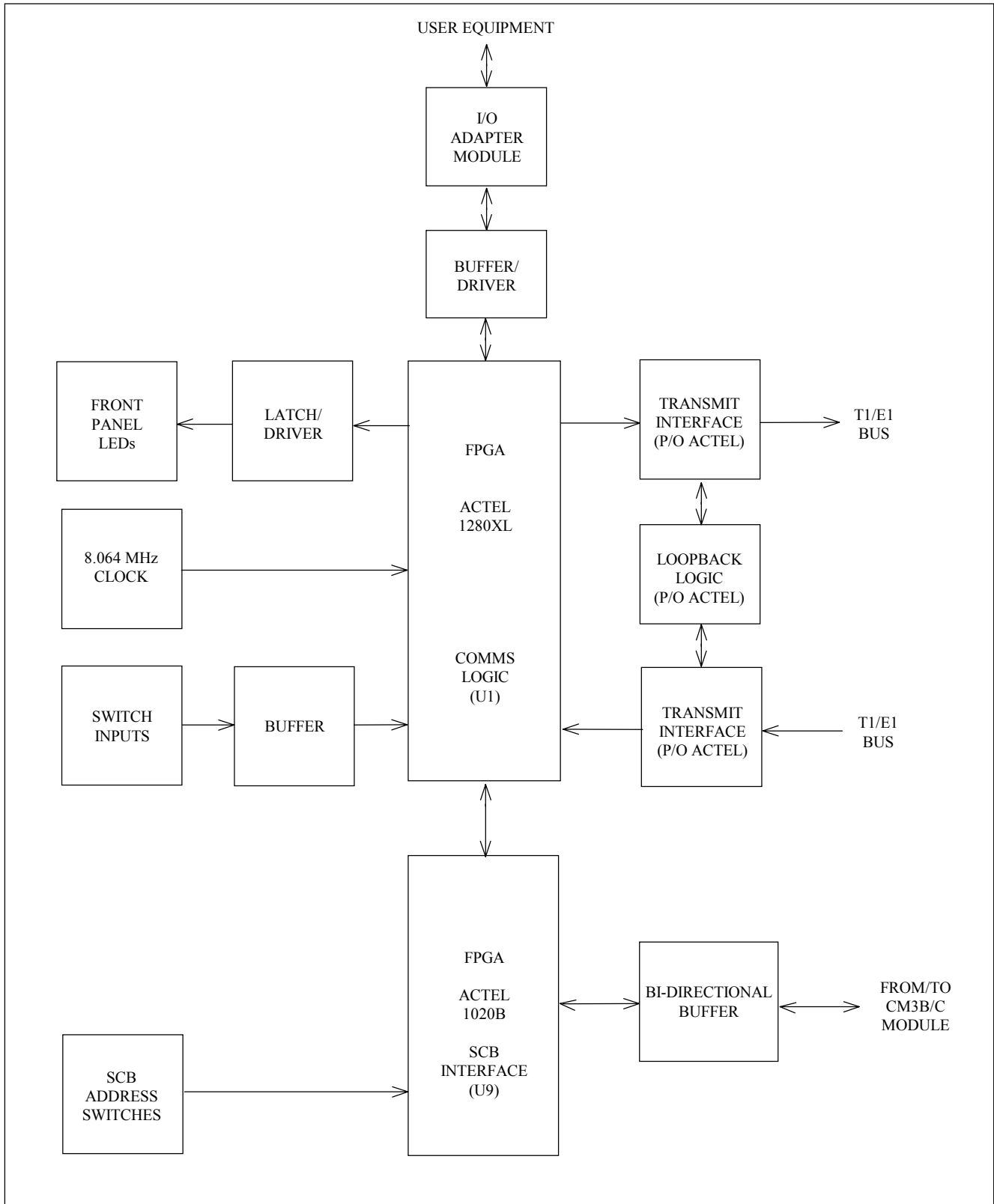

Figure 16- 9. RFL DS-562I Block diagram.

## **T1/E1 RECEIVE CIRCUIT**

The incoming serial data stream is received from the T1/E1 bus by the receive interface and routed to the user equipment. If addressing is being used in the 56 Kbps mode, coded address and security information is extracted and verified, and then compared to the selected received address.

## **LOOPBACK LOGIC**

The T1/E1 transmit and receive interface circuits are interconnected by loopback logic inside the Actel 1280XL. The equipment loopback causes the data received from the user equipment to be read into a buffer and then retransmitted back to the user equipment. The payload loopback places the T1/E1 received data into a buffer and then retransmits it via the T1/E1 transmit circuit. Synchronizing circuits in the loopback logic compensates for varying phase relationships between the T1/E1 transmit and receive bus signals. A three position switch on the module front panel enables the user to select equipment loopback, payload loopback or no loopback.

### **NOTE**

If this unit is used for protective relaying applications, disable the protection equipment at both ends before using equipment loopback or payload loopback modes.

## **ALERTS AND ALARMS**

If payload loopback and equipment loopback are enabled, the DS-562I will issue a module level alert signal to the shelf common module.

If addressing is enabled and there is a loss of addressing, the DS-562I will issue a module level alert signal to the shelf common module.



## REMOTE CONTROL INTERFACE

When the RFL DS-562I is installed in an IMUX 2000 multiplexer, it can be operated under local or remote control. When under remote control, most of the module setup parameters can only be changed through the RS-232 remote port on the shelf Common Module. See the IMUX 2000 manual for information on using the remote control interface.

The remote control interface for the RFL DS-562I involves two sets of codes: “P” (parameter) codes, and “S” (status) codes. The RFL DS-562I reports itself as a “Type 119” module.

### “P” CODES

“P” codes, when used in the parameter field on an SCL “SET” command, allow the user to set certain parameters on the RFL DS-562I by remote control, just like setting DIP switches on a module under local control. “P” codes also appear in the response to a “CONFIG?” query, providing a list of the RFL DS-562I current parameter settings. A typical RFL DS-562I response to a “CONFIG?” query looks like this:

```
*OK
CHANNEL CARD 3, TYPE 119
UNDER REMOTE CONTROL
SRVC = ON
P01 = 13 (B00001101)
P02 = 0 (B00000000)
P03 = 0 (B00000000)
P04 = 190 (B10111110)
P05 = 0 (B00000000)
```

There are five “P” codes for the RFL DS-562I; “P1” through “P5”. Each “P” code is displayed as a decimal number from 0 to 255, followed by its eight-digit binary equivalent in parenthesis. Table 12 lists the meaning of all “P” codes for the RFL DS-562I module.

**Table 16 - 13** Remote Configuration Settings (“P” codes)

P Code	Bits Used	Value	Description
SRVC	...	ON	Turns service on (module enabled).
		OFF	Turns service off (module disabled).
P01	B 0 0 0 0 0 0 0 0 ↑↑↑↑↑	T1: 1 to 24 E1: 1 to 31	Selects the receive and transmit timeslot. Used in 56K mode only. *
P02	B 0 0 0 0 0 0 0 0 ↑↑↑↑↑↑	0 to 63	Sets the transmit address (See Table 8). Used in 56K mode only. *
P03	B 0 0 0 0 0 0 0 0 ↑↑↑↑↑↑	0 to 63	Sets the receive address (See Table 8)
P04	B 0 0 0 0 0 0 0 0 ↑	0	Octet timing OFF
		1	Octet timing ON
	B 0 0 0 0 0 0 0 0 ↑	0	Normal receive clock polarity
		1	Inverted receive clock polarity
	B 0 0 0 0 0 0 0 0 ↑	0	Normal transmit clock polarity
		1	Inverted transmit clock polarity
	B 0 0 0 0 0 0 0 0 ↑	0	Squelch OFF
		1	Squelch output to user equipment upon loss of valid address
	B 0 0 0 0 0 0 0 0 ↑	0	No remotely commanded equipment loopback (may be overridden at board)
		1	Remotely commanded equipment loopback
	B 0 0 0 0 0 0 0 0 ↑	0	No remotely commanded payload loopback (may be overridden at board)
		1	Remotely commanded payload loopback
	B 0 0 0 0 0 0 0 0 ↑	0	64 Kbps data rate
		1	56 Kbps data rate
B 0 0 0 0 0 0 0 0 ↑	0	Transmit on bus B	
	1	Transmit on bus A	
P05	B 0 0 0 0 0 0 0 0 ↑	0	T1 carrier
		1	E1 carrier
	B 0 0 0 0 0 0 0 0 ↑	0	No handshaking delay
		1	8 microsecond handshaking delay (approx.)

\* It is recommended that the TX and RX addresses are both set to a value other than 0 if the addressing function is being used.

## “S” CODES

“S” codes appear in response to a “STATUS?” query. There are four “S” codes for the RFL DS-562I. Like the “P” codes, each “S” code is a number displayed in both decimal and binary form.

A typical response to a “STATUS?” query looks like this:

```
*OK
CHANNEL CARD 3, TYPE 119
S01 = 0 (B00000000)
S02 = 57 (B00111001)
S03 = 0 (B00000000) (not currently used)
S04 = 0 (B00000000) (not currently used)
```

These codes provide information on the status of several conditions on the RFL DS-562I module. Table 13 lists the meaning of all “S” codes for the RFL DS-562I module.

**Table 16 - 14.** Remote status messages (“S” codes)

Code	Bits Used	Value	Description
S01	B 00000000 ↑↑↑	0	MA-406IA installed (RS-449), DCE mode.
		1	MA-406IA installed (RS-449) or MA-410I (X.21), DTE mode.
		2	MA-409IA installed (V.35), DCE mode.
		3	MA-409IA installed (V.35), DTE mode.
		4	MA-407I installed (G.703 contradirectional).
		5	MA-408I installed (G.703 codirectional).
		6	MA-410I installed (X.21), DCE mode.
		7	MA-600 installed (short haul fiber)
S02	B 00000000 ↑	0	Service off (module disabled).
		1	Service on (module enabled).
	B 00000000 ↑	0	RX address is disabled, or RX address is enabled and the DS-562I is not receiving a properly addressed signal. Used in 56K mode only.
		1	RX address is enabled, and the DS-562I is receiving a properly addressed signal. Used in 56K mode only.
	B 00000000 ↑	0	The transmit address is disabled. Used in 56K mode only.
		1	The transmit address is enabled. Used in 56K mode only.
	B 00000000 ↑	0	The equipment loopback is disabled.
		1	The equipment loopback is enabled.
	B 00000000 ↑	0	The payload loopback is disabled.
		1	The payload loopback is enabled.
	B 00000000 ↑	0	The DS-562I is not receiving data from the remote equipment.
		1	The DS-562I is receiving data from the remote equipment.
	B 00000000 ↑	0	The DS-562I is not transmitting data from the remote equipment.
		1	The DS-562I is transmitting data from the remote equipment.
S03	Not currently used		
S04	Not currently used		

## LOOPBACK TESTING

A local loopback test is performed when the module is first installed, or any time the integrity of the module needs to be checked. The loopback test can be performed on modules in terminal systems or drop/insert systems. The loopback test is a tool for locating problems, but is no substitute for troubleshooting expertise.

Before starting a loopback test, make sure the following conditions have been met:

1. The DS-562I module and I/O adapter must be installed in an RFL IMUX 2000 chassis.
2. Power must be applied to the system.
3. The module must be out of service.
4. If the module is set for 56 Kbps, the transmit and receive addresses must be set to the same value, or set to zero.

A telecommunications test set that can accept RS-449/422, X.21/V.11, CCITT V.35, or CCITT G.703 signals (depending on the adapter module used), will be required for the loopback test (Telecommunications Techniques Corporation Fireberd 2000 or equivalent).

### VERIFICATION TEST

1. Press the Group toggle switch on the CM-3 left or right until the function display reads LPBK. Then push the SET toggle switch left until the function display reads EqLB. At this time push the SET toggle switch twice to the right.

#### NOTE

Equipment Loopback on the CM-3 will loopback all DS0 channels within that shelf

**The green LED above the SET toggle switch should blink after the first push and should be steady after the second push.**

**The yellow loopback LED on the CM-3 and the yellow LED on the power supply should be lit, indicating that the system is in local loopback.**

2. Connect a test set to the cable assembly in accordance with the manufacturers procedures. Then perform a bit error rate test.

**For test criteria, use a 63 or 511 test pattern. Alternately, use a 109 or lower bit pattern.**

3. Observe that zero errors are indicated on the receive side of the test set.

**If an error count occurs, check all option selections and repeat steps 1 through 3. If the error count persists, check the following:**

- a. **Make sure the test set is correctly set up.**
- b. **Make sure the test set cable is correctly connected.**
- c. **Make sure the module under test is correctly installed.**
- d. **Make sure the cable assembly is firmly and correctly connected.**

**If the error source is localized to the module or the cable assembly, return the defective component to RFL for repair. If an error count persists after these steps have been taken, check for an outside error source.**

## **TROUBLESHOOTING**

Use the following procedure to determine whether a problem is being caused by the RFL DS-562I or by some other part of the system.

1. If more than one module is on the same time slot, remove those modules that are known to be good.
2. Perform a local loopback test, as described in steps 1 through 4 of the Loopback Testing procedure.
3. If the loopback test indicates that the module is functioning properly, then check that the terminal equipment is functioning properly. If so, then the test is complete. If not, then check for an outside error source.
4. If the error count persists, then swap modules. Replace the module with another that is known to be functioning properly. If the replacement module is OK, then use the Repair/Return procedure in the General Information Section of the manual to return the defective module to RFL for repair.
5. If proper function is not obtained, perform individual multiplex tests as described in the multiplexer manual. If an error count still persists after these steps have been taken, then check for an outside error source.